

STRUCTURE 5D-73, BURIAL 196,
TIKAL, PETEN, GUATEMALA

A PRELIMINARY REPORT

by

Nicholas Matthew Hellmuth

Submitted to the Department of Anthropology
in partial fulfillment of the requirements
for the degree of Bachelor of Arts with Honors

Harvard College
March 31, 1967

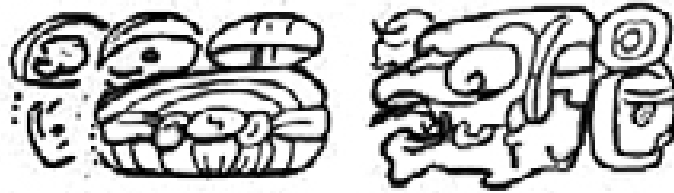

STRUCTURE 5D-73, BURIAL 196,
TIKAL, PETEN, GUATEMALA

A PRELIMINARY REPORT

by

Nicholas Matthew Hellmuth

Submitted to the Department of Anthropology
in partial fulfillment of the requirements
for the degree of Bachelor of Arts with Honors

Harvard College
March 31, 1967

published and distributed by the
Foundation for Latin American Anthropological Research
Rollins Campus Box 2675, Winter Park, FL 32789

edition limited to 50 copies
of which this is copy

TABLE OF CONTENTS
VOLUME 1 STRUCTURE 5D-73

	Page
PREFACE	i
ABSTRACT	iii
ABBREVIATIONS	iv
 INTRODUCTION	 1
Justification of the Excavation	1
Location	2
Previous Mention and Excavation	2
Previous Investigation by the Tikal Project	6
Appearance of the Mound before Excavation	8
Extent of Clearing	9
Extent of Excavation	10
Standards of Recording	14
Acknowledgements	14
Operation Numbers	15
Limitations	16
 EXCAVATIONS	 17
PRE-STR.5D-73 TIME-SPANS	17
Pre-Str.5D-73: Floor A	17
APPEARANCE OF THE STR.5D-73 LOCATION PRIOR TO THE CONSTRUCTION THEREOF	18
Evidence for or against an Earlier Structure	18
THE BASAL PLATFORM	19
STR.5D-73: TIME-SPANS	22
Notes of the sequence of Activity	23
STR.5D-73: TIME-SPAN 9 - DESIGN PHASE	24
STR.5D-73: TIME-SPAN 8 - DESIGN OF A MAYAN NOBLE	25
STR.5D-73: TIME-SPAN 7 - CONSTRUCTION OF THE TOMB	26
Construction Stage 10: Digging the Tomb Pit	26
Construction Stage 9: Fill for the Bench	28
Artifacts	28
Nature of the Plaza Fill which was cut through	28
Construction Stage 8: Erection of the Tomb Walls	29
North Wall	29
South Wall	31
East Wall	32
West Wall	32
Masonry	32
Wall Cross-Beams	32
Artifacts from the Fill behind the Walls	40
Construction Stage 7: Plastering of the Tomb Walls	41
Construction Stage 6: Facing put on Bench Front	42
Construction Stage 5: Plastering of Tomb Floor and Bench Top	42

	Page
Construction Stage 4: The Internment	42
Construction Stage 3: Cloth stretched Across Burial at Wall-top level	45
Construction Stage 2: Erection of the Vaults	47
East Vault	47
West Vault	49
North Vault	50
South Vault	50
Masonry	51
Mortar Caught in the Wall-top Cover Cloth	54
Coursing	55
Mortar Layers at Course Top Level	55
Joints and Sequence of Vault Construction	56
Masonry size	57
Vault Cross Beams	57
Construction Stage 1: Wooden Beam Ceiling	58
STR.5D-73: TIME-SPAN 6 - CONSTRUCTION OF THE PYRAMID	
Construction Stage 12: Offerings of Flint and Obsidian Chips	61
Later Construction Stages	62
Features of the Flint Bearing Fill	63
Artifacts	64
Basal Platform	65
Masonry	67
Complications	67
Construction Stage 10: 4th Masons' Stairway	68
Masonry	70
Fill South of Str.5D-73 : 4th Masons' Stair	71
Artifacts	71
Construction Stage 9: Partial Rip-out	71
Construction Stage 8: Laying a Rough "Floor" Turning-up to the Rip-out	72
Construction Stage 7: 3rd Masons' Stairway	73
Masonry	73
Fill	74
Artifacts	75
Construction Stage 6: 2nd Masons' Stairway	75
Masonry	75
Fill	76
Artifacts	76
Construction Stage 5: 1st Masons' Stairway	77
Masonry	77
Fill	77
Wooden Poles in Fill	77
Artifacts	79
Problematical Deposit 171	79
Construction Stage 4: Pyramid Facing Masonry	80
Ground Plan	81
Facing masonry	81
Step-inset	82

	Page
Step-terrace Outsets, East Side, Str.5D-37	85
Discovery of the Step-terrace Outsets	85
East Side South Step-terrace Outsets	86
Step-masonry	87
Side-wall Masonry	88
East Side North Step-terrace Outsets	88
East Side Upper Level Step-terrace Outsets	91
Stair Inset-wall Outsets	92
South Stair Inset-wall Outsets	93
West Side Step-terrace Outset	93
Purpose of the Step-insets	94
Str.5D-72	95
Construction Stage 3: Building Platform	95
Upper Level of the Building Platform	97
Possible Additional Level Higher Up	98
Possible Additional Level before Main "Step- Up"	98
Front Fill Retaining Wall	97
Side Inset	98
Facing Masonry	98
Artifacts	98
Evidence for and against there ever having been a Temple Building on Top	100
Construction Stage 2: Final Front Stairway	103
Step Masonry	104
Stair Side-wall Masonry	105
Artifacts	105
Building Platform Stairway	105
Stair Masonry	106
Constructional Activity after the Pyramid was finished	106
Plaza Floors	107
STR.5D-73: TIME-SPAN 1 - THE ROBBERY TUNNEL	107
Artifacts	109
Who dug the Tunnel	110

TABLE OF CONTENTS

VOLUME II BURIAL 196

	Page
INTRODUCTION	111
EXCAVATIONS	
Method of Excavation	111
Offerings of Flint	113
Finding the Tomb	113
Excavating the Tomb Chamber	114
Operation Number	117
Location	118
GRAVE	118
INDIVIDUALS AND ASSOCIATED MATERIALS	
INDIVIDUAL	118
ASSOCIATED MATERIALS: Within Grave	119
Acknowledgments	119
List of Offerings within the Tomb	120
THE FLOOR AREA	128
Polychrome Tripod Plates with Dress-shirt Designs	129
Possible Origins of the Dress-shirt Design	130
Further Variations within the Group of Tripod Plates	131
Plain Ware Vessels	132
Flat-bottomed, Flaring-sided Vessel, 117A-46	132
Flat-bottomed, Flaring-sided Vessel, 117A-47	132
Pile of Vessels	133
Flat-bottomed Polychrome Bowl, 117A-26	133
Black Rattle-bowl, 117A-35	134
Orange Rattle-bowl	134
Polychrome Bowl with Quatrefoil Design, 117A-30	135
Small Black Fluted Bowl, 117A-32	136
Small Black Flat-bottomed Bowl, 117A-33	136
Small Black Fluted Bowl, 117A-31	137
Cylinder Vessel with Black-on-red Spiral Decoration	137
Flat-bottomed Cylinders with Incised Panels	138
Derivation of the Design on 117A-8 from that on 4P-2	141
The Glyph Band	142
The Head: The Headdress	142
The Head: The Face	143
Summary	143
The Two remaining Deities	144
Black Cylindrical Vessels	145
Black Stucco-rimmed Cylinder, 117A-17	145
Fluted Vessels	146

Vessels with a single Vertical Groove, 117A-21, -22	146
Tall Fluted Vessel, 117A-18	146
Fluted Cylinder, 117A-20	147
Double Grooved Fluted Cylinders, 117A-19, -23, -24	147
Fluted Vessels	149
Miscellaneous Single Vessels	149
Polychrome Bowl with Quatrefoil Design, 117A-30	149
Flat-bottomed Polychrome Bowl, 117A-27	150
Flat-bottomed Flaring-sided Polychrome Bowl, 117A-28	151
Offerings clearly Fallen from the Bench	152
Stucco Fragments possibly fallen from the Bench	152
CONCLUSION OF DESCRIPTION OF POTTERY OFFERINGS OF THE AISLE	153
Polychrome Cylinder with painted Human Figures, 117A-2	153
The Human Figures	154
Polychrome Cylinder with Throne Scenes, 117A-1	157
The Glyphs	158
The Upper Band of Glyphs	158
The Figure Glyphs	159
The Bird Men: The Bare-backed Bird-man	159
The Bird-Men: The Bird-man with Offerings	162
The Offerings	162
The Throne Figures: The Figure on the Jaguar Skin Covered Throne	163
The Throne Figure with the offerings	165
The Throne	166
OFFERINGS ON THE BENCH	
THE POTTERY OFFERINGS	
Polychrome Cylinder with Throne Scene, 117A-3	167
The Fat Man	169
The Figure on the Throne	169
The Throne and Offering	170
The Panel	170
Large Cooking Pot, 117A-48	171
Large Tripod Plate with Dress-shirt Design, 117A-37	171
WOODEN OFFERINGS	172
Large Wooden Bowl with Stuccoed Rim, 117A-100	173
Wooden bowl filled with Hematite, 117A-99	174
CONTAINERS OF STONE	
White Stone Vessel, 117A-49	174
JADE OFFERINGS	
JADE NOT WORN BY THE DECEASED	175
The Jade Jaguar, 117A-50	175
Jade Mosaic Vessel, 117A-51	177
JADE WORN BY THE DECEASED	180

Jade Headband, 117A-57	180
Tubular Jade Bead with Carved Human Figures, 117A-62	181
Large Earplugs possibly belonging to a Headdress, 117A-52	183
Earplug Assemblage, 117A-66, -67	184
Five-stranded Jade Necklace, 117A-65	185
Carved Jade Pendant, 117A-58	187
Jade Beads in the Shell Bead Belt	188
Jade Pelvis Pendant, 117A-59	188
Tubular Jade Bead held in Left Hand, 117A-61	188
Objects in Right Hand, 117A-64, -82, -83a .	189
Jade Wrist Bracelets with Pendants of Fitted Shell, 117A-53, -54, -55, and -56	190
Spherical Jade Beads scattered over the Body, 117A-63	191
OFFERINGS OF SHELL	
Spondylus Shells associated with the Spherical Jade Beads, 117A-70	192
Large Shell over Head of the Deceased, 117A- 69	195
Ovoid-shaped Shell Pendant, 117A-72	196
Shell Pendants for Jade Wristlets	196
Belt of Spondylus Shell and Jade Beads, 117A- 79	196
Cut Pieces of Nacreous Shell, 117A-73	198
Nacreous Shell Pendant, 117A-80	198
Shell Pendant, 117A-81	198
Pearl Necklace, 117A-84	199
MISCELLANEOUS OFFERINGS	
Incised Stingray Spines, 117A-85	199
The Glyphs	200
Jaguar Paw Bones, 117A-88	200
PILE OF BONES AND SHELL OFFERINGS	
Carved-incised Bones, 117A-85	201
Shell "Tweezers", 117A-76	201
Other Tweezer Ends, 117A-78	203
Olivella Shells, 117A-75	203
Unmodified Shell, 117A-74	203
Worked Bone, 117A-91	204
Bone (Perforator ?), 117A-92	204
Teeth, 117A-89	204
Miscellaneous Shells, 117A-78	204
Worked Bone, 117A-90	205
Worked Bone not found with Others, 117A-90g	205
PYRITE (?) PLAQUES	
Smallest Pyrite Mosaic Plaque, 117A-93	205
Small Pyrite Mosaic Plaque, 117A-94 . .	206
Large Slate-backed Pyrite Mosaic Plaque, 117A-95	207

Largest Pyrite Mosaic Plaque, 117A-96 .	208
Pyrite Mosaic Plaques	210
More Miscellaneous Offerings	210
Stuccoed and Painted Wooden (?) Vessel found fallen from the bench, 117A-97 .	210
Jaguar Hide (?)	210
Area of Golden Colored Residue, 117A-96	211
Cinnabar	211
CONCLUSIONS	214

		Page
Figure 1	Map of the Maya area showing the location of Tikal .	1
Figure 2*	Isometric reconstruction of Str.5D-73	1
Figure 3	Graffiti	2
Figure 4	Tikal Project map of the Great Plaza area	3
Figure 5	Maudslay's map of Tikal	3
Figure 6	Tozzer and Merwin's map of Tikal	6
Figure 7	Plan, section, and elevation of tunnel system between Str.5D-72 and Str.5D-73	11
Figure 8	North-south section through Bu.196	26
Figure 9	East-west section through Bu.196	26
Figure 10	Bu.196 North side masonry detail elevation	32
Figure 11	Bu.196 South side masonry detail elevation	32
Figure 12	Bu.196 East side masonry detail elevation	32
Figure 13	Bu.196 West side masonry detail elevation	32
Figure 14	Bu.196 sequence of construction of the tomb chamber .	42
Figure 15	Str.5D-73, centerline tunnel, wooden poles in fill . .	78
Figure 16	Str.5D-73, east side, lowest terrace, looking north at the south elevation of the step-inset with the steps shown also in section; Str.5D-72 in section . .	82
Figure 17	Str.5D-73, east side, lowest terrace, east elevation and south profile	82
Figure 18a	Str.5D-73, east side, lowest terrace; east masonry detail elevation of the remains of the 'step-inset' .	82
Figure 18b	Str.5D-37, plan showing 'step-outset-terraces'	82
Figure 18c	Str.5D-37, east elevation	82
Figure 19a	Str.5D-73, north-south centerline section through building platform	96
Figure 19b	Str.5D-73, the building platform reconstructed with a five step stair	100

LIST OF PHOTOGRAPHS VOL. II

		Page
Photo 39a	Str.5D-73, front stairway	114
b	Centerline tunnel, masons' stair # 1 in background . .	114
c	2nd masons' stair	114
d	Robbery tunnel as first seen from centerline tunnel . .	114
e	Robbery tunnel chamber as found	114
f	Robbery chamber cleared of accumulated debris	114
g	Tomb cut in floor with fill retaining wall behind . . .	114
h	Entrance to the tomb (bottom right)	114
i	Bu. 196, west side as found	114
Photo 40	The writer and workmen working from the scaffolding .	116
Photo 41	The writer working from the scaffolding	116
Photo 42	Bu. 196 after several weeks of excavation	116
Photo 43	Bu. 116, Temple I	114
Photo 44	The writer removing collapsed debris from around offerings on the floor	114
Photo 45	Bu. 196, offerings on the floor	129
Photo 46	Tripod plates on the floor, east	130
Photo 47	Tripod plates on the floor, center	130
Photo 48	Tripod plates on the floor, west	130
Photo 49	117A-39	130
Photo 50	117A-44	130
Photo 51	117A-44	130
Photo 52	117A-43	130
Photo 53	117A-45	130
Photo 54	117A-37	130
Photo 55	117A-36	130
Photo 56	Plain ware vessel, 117A-46	132
Photo 57	Plain ware vessel, 117A-47	132
Photo 58	Looking west, pile of pottery vessels	133
Photo 59	117A-26, flat-bottomed dress-shirt design bowl	134

	Page
Photo 60	117A-34, orange rattle bowl 134
Photo 61	117A-35, black rattle bowl 134
Photo 62	117A-30, bowl, with quatrefoil design 134
Photo 63	117A-29, bowl, with quatrefoil design 134
Photo 64	117A-32, 117A-31, small black fluted bowls 136
Photo 65	117A-25, cylinder with black spiral design 137
Photo 66	117A-13, 117A-6, 117A-4, stuccoed-incised cylinders . 139
Photo 67	117A-10, 117A-9, 117A-5 139
Photo 68	117A-15, 117A-16, 117A-7 139
Photo 69	117A-8, 117A-12, 117A-11 139
Photo 70	Black cylinders as found on the floor 145
Photo 71	117A-19, 117A-20, 117A-22 146
Photo 72	117A-17, 117A-18, 117A-33 147
Photo 73	117A-27, side and interior 150
Photo 74	117A-27, base 150
Photo 75	117A-28, interior 150
Photo 76	117A-28, exterior 150
Photo 77	117A-2, cylinder with throne scene 154
Photo 78	117A-1, cylinder with bird-man throne scene 158
Photo 79	117A-3, cylinder with throne scene 169
Photo 80	117A-3 169
Photo 81	117A-3, panel 169
Photo 82	117A-3, hand gestures 169
Photo 83	117A-49, alabaster container 175
Photo 84	Jade jaguar, alabaster vessel, and pottery cylinder . 176
Photo 85	117A-50, jade jaguar 176

	Page
Photo 86	Jade jaguar and jade mosaic vessel before excavation 178
Photo 87	Jade mosaic vessel as found 178
Photo 88	Jade mosaic vessel partially reassembled 178
Photo 89	Partially restored jade mosaic vessel from Bu. 116 . . 178
Photo 90	The skeleton as seen from above 181
Photo 91	117A-57, jade headband 181
Photo 92	117A-62, carved, tubular jade bead 182
Photo 93	Jade earplugs 183
Photo 94	117A-65, jade necklace 186
Photo 95	117A-58, jade face pendant 187
Photo 96	Jade offerings 188
Photo 97	117A-58, 117A-61, 117A-59, jade 188
Photo 98	Jade wristlet 190
Photo 99	Jade wristlets 190
Photo 100	Jade beads from over body, 117A-63 191
Photo 101	Bu. 116, Temple I showing shell placement 192
Photo 102	117A-79, belt of spondylus and jade beads 197
Photo 103	117A-85, stingray spines 200
Photo 104	117A-86, etc. pile of bones 202
Photo 105	117A-86, carved-incised bones 202

LIST OF FIGURES VOL. II

		Page
Fig. 27	Plan of Bu. 196 showing the offerings	120
Fig. 28	Detail plan showing location of tripod plates	129
Fig. 29	117A-38	130
Fig. 30	117A-39, section and interior	130
Fig. 31	117A-40	130
Fig. 32	117A-41	130
Fig. 33	117A-42	130
Fig. 34	117A-43	130
Fig. 35	117A-44	130
Fig. 36	117A-45	130
Fig. 37A	117A-36	130
Fig. 37B	117A-37	130
Fig. 38	Section through 117A-36, -37	130
Fig. 39	Possible origins of dress-shirt design	130
Fig. 40	Section through 117A-42, -40, -45, -41	130
Fig. 41	Section through 117A-37, -44, -43, -38	130
Fig. 42A	Section through 117A-47, plain ware vessel	130
Fig. 42B	Section through 117A-46, plain ware vessel	132
Fig. 43	117A-26	134
Fig. 44	117A-34	134
Fig. 45	117A-35	134
Fig. 46	117A-30	135
Fig. 47A	117A-29, section	135
Fig. 47B	117A-29, exterior base	135
Fig. 48A	117A-32	136

		Page
Fig. 48B	117A-31	136
Fig. 48C	117A-33	136
Fig. 48D	117A-25	137
Fig. 49	Detail plan showing location of stuccoed-incised cylinders	138
Fig. 50	117A-4	139
Fig. 51	117A-5	139
Fig. 52	117A-6	139
Fig. 53	117A-7	139
Fig. 54	117A-8	139
Fig. 55	117A-9	139
Fig. 56	117A-10	139
Fig. 57	117A-11	139
Fig. 58	117A-12	139
Fig. 59	117A-13	139
Fig. 60	117A-14	139
Fig. 61	117A-15	139
Fig. 62	117A-16	139
Fig. 63	Evolution of the facial features of the deity	141
Fig. 64	4P-2, design from Bu. 116 vessel	142
Fig. 65	Comparison between Bu. 196 and Bu. 116 stuccoed- incised cylinders	143
Fig. 66	Comparison between 4P-2 and 117A-8 series	143
Fig. 67	Detail plan showing location of black fluted vessels	145
Fig. 68	Sections through the black cylinders	146
Fig. 69	117A-27	150
Fig. 70	117A-28	150
Fig. 71	Roll out design of 117A-2	154

	Page
Fig. 72	Decorative elements 154
Fig. 73	Roll out design of 117A-1 158
Fig. 74	Section and interior design of 117A-1 157
Fig. 75	Water lily designs 161
Fig. 76	Headdress 'stacks' 161
Fig. 77	Thrones with oval backrests 164
Fig. 78	Roll out design of 117A-3 169
Fig. 79	117A-48 171
Fig. 80	117A-49, onyx marble vessel 175
Fig. 81	Floral (?) design on forehead of jade jaguar 176
Fig. 82A	Figure on 117A-62, carved tubular jade bead 182
Fig. 82B	Acrobatic figure from Uaxactun pottery scene 182
Fig. 83	Large earplug assemblage, 117A-52 184
Fig. 84	Sketch plan of jade necklace 186
Fig. 85	1:1 plan of jade necklace as found 186
Fig. 86	Jade beads in shell 'belt' 188
Fig. 87	Jade pelvis pendant, 117A-59 188
Fig. 88	Tubular jade bead held in left hand 188
Fig. 89	Plan showing location of spondylus shells and jade beads 191
Fig. 90	Shell pendant, 117A-72 196
Fig. 91	Pile of bone and shell objects 202

Figure 19c	Str.5D-73, the building platform reconstructed with a four step stair	100
Figure 20	Str.5D-73, masonry detail elevation, (east) stair side-wall	105
Figure 21	Str.5D-73, plan	100
Figure 22a	Str.5D-73, front elevation	100
Figure 22b	Str.5D-73, rear elevation	100
Figure 22c	Str.5D-73, east elevation	100
Figure 23	Sketch plan of basal platform and lowest pyramid terrace showing tomb and tunnels, Str.5D-73	100
Figure 24	Str.5D-73, section of the robbery tunnel	108
Figure 25	East-west detail section of Str.5D-72, -73	107
Figure 26	Str.5D-73, north-south centerline section	111

LIST OF PHOTOGRAPHS

VOLUME I

		Opposite Page
Photo 1	Str.4E-36, one of the "Twin Pyramids"	1
Photo 2	Str.5D-1, Temple I	2
Photo 3	Str.5D-73, front (northwest corner) before bushing . .	8
Photo 4	Str.5D-73 as seen from the Great Plaza, before excavation	9
Photo 5	Rear of Str.5D-73 after bushing but before excavation	9
Photo 6	Guatemalan workman excavating tunnel between Strs.5D- 72 and -73	10
Photo 7	Tunnel between Strs.5D-72 and -73, lower level	10
Photo 8		
Photo 9		
Photo 10	The front of Str.5D-73 before excavation but after bushing, as seen from the top of Temple II	11
Photo 11	The front of Str.5D-73 after complete excavation, as seen from the top of Temple II	11
Photo 12	Str.5D-73 with east stair side-wall excavated, as seen from the Great Plaza	11
Photo 13	Bu.196, east side showing excavator's method of en- trance, before excavation	32
Photo 14	West side of Bu.196 before excavation	32
Photo 15	Bu.196, upper courses of north wall with stretcher stones collapsed but butts of headers visible	34
Photo 16	East (?) end of tomb before excavation showing fallen wooden wall beams	37
Photo 17	Looking west at the southeast corner of the tomb walls, showing fallen wall beams	37
Photo 18	East wall of Bu.196 showing dent in buckled wall caused by east wall beam	38
Photo 19*	East wall of Bu.196, wall top plaster turn-over with the vault stones removed	41
Photo 20	Bu.196, northeast corner showing gobs of vault mortar caught by east wall across beam and cloth	46
Photo 21	Bu.196, southeast corner showing gobs of vault mortar caught by wall top cover cloth over wall beam	46

Photo 22	Bu.196 south wall top showing vault mortar caught by wall top tomb cover-cloth	47
Photo 23	Bu.196, upper vault courses and ceiling beam holes . .	51
Photo 24	Bu.196, upper vault courses	51
Photo 25	Bu.196, finger marks in vault mortar on north vault . .	53
Photo 26	Bu.196, vault mortar showing drip lines	54
Photo 27	Bu.196, vault mortar showing drip lines	54
Photo 28	Ceiling of Bu.196 with wood poles collapsed, showing flint and obsidian offerings	61
Photo 29	Centerline tunnel with the author in front of tomb cut in the floor and fill retaining wall	62
Photo 30	Str.5D-73: 3rd masons' stair	73
Photo 31	Str.5D-73: 2nd masons' stair	75
Photo 32	South side of Temple I with remains of 'step-insets' barely visible	82
Photo 33	Building platform of Str.5D-73 after partial excavation, as seen from Temple II	97
Photo 34	Building platform of Str.5D-73 with excavation com- pleted, as seen from Temple II	97
Photo 35	Str.5D-73, main stairway, northwest corner of west stair side-wall	103
Photo 36	Centerline tunnel with robbery cut as first seen . . .	108
Photo 37	Robbery tunnel chamber before excavation	109
Photo 38	Robbery tunnel looking from the centerline to the out- side, after removal of silt and accumulated debris .	110

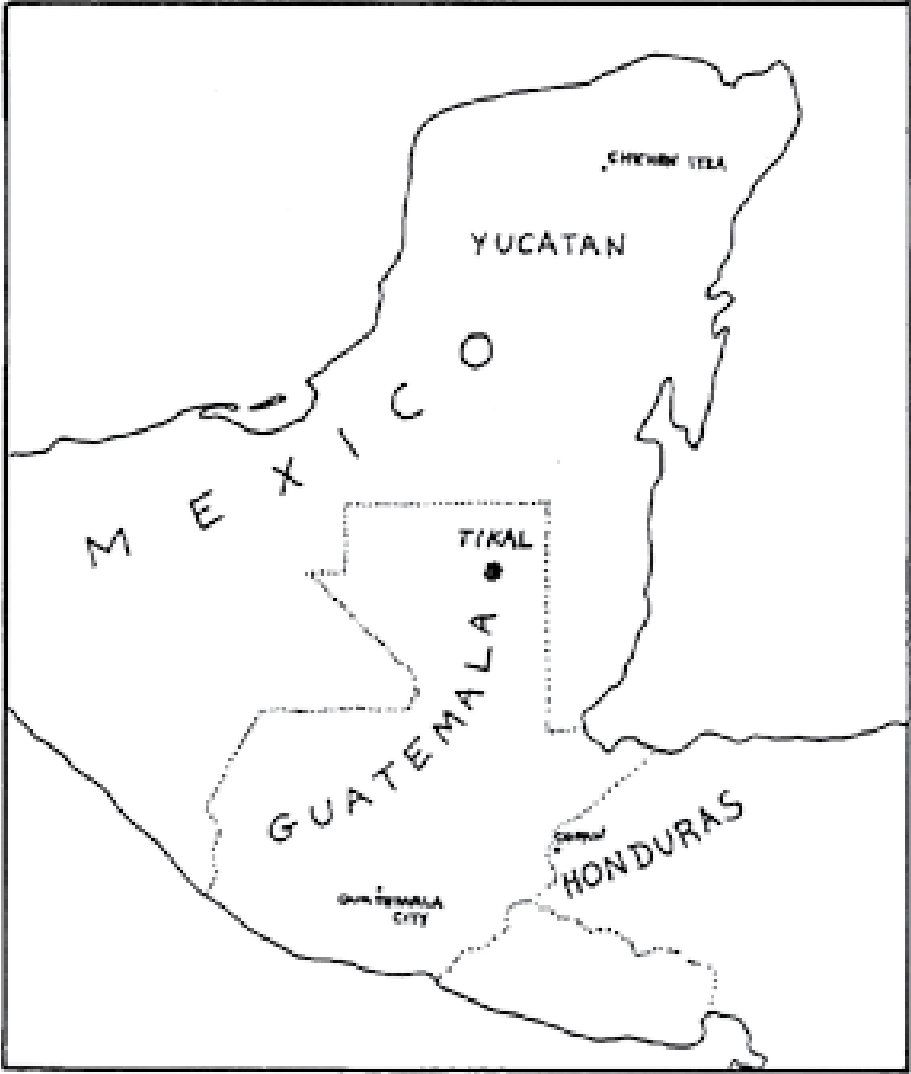

Fig. 1 Map of the Maya area showing the location of Tikal

PREFACE

The writer worked at Tikal from Feb. 1965 to Feb. 1966, during a year's leave of absence from Harvard College. The structure which is the subject of this thesis, Str.5D-73, was excavated from August 1965 until Jan. 1966.

Tikal, which lies in the Peten rain forest of northern Guatemala (Fig. 1), was the largest of the Mayan ceremonial centers. During Late Classic times (A.D. 550-900) the built-up area covered many square miles and had at least 10,000 inhabitants (Haviland). Tikal seems to have been first inhabited in 600 B.C. and was abandoned by the priest-rulers suddenly around A.D. 900. Some peasants stayed at the site for another hundred years or so, after which the site was abandoned to the jungles not to be re-discovered until 1858.

In 1946, the University Museum of the University of Pennsylvania began excavations at Tikal, digging from 4 to 12 months a year every year until 1966. During the year that the author was in Tikal, the Project Director was Dr. William R. Coe and the Field Director, Mr. George Guillemin. Except for the last week that the author was working on Str.5D-73, Dr. Coe was not in Tikal. The tomb, Bu.196, within Str.5D-73, was excavated during the two-month Christmas vacation and during the off season. George Guillemin was present in camp approximately one of these months.

Blank Page

Dr. Nicholas Hellmuth

www.FLAAR.org

ABSTRACT

Str.5D-73 is a 45 m. high, five terraced, Late Classic pyramid (Fig. 2); similar to the pyramid which supports Temple I (Photo 2), but smaller. The interesting feature of Str.5D-73 is that it is the only pyramid of its type at Tikal which does not sustain a masonry temple building. Buried below the approximate center of the structure was a large tomb chamber, Bu.196. On a bench within the tomb was the supine body of a male, surrounded by a great wealth of jade jewelry. To one side of the bench were placed over 40 pottery vessels containing food. Within the burial chamber was evidence that the body was placed in the tomb before any of the tomb's vault had been constructed. After the burial was completed the chamber was sealed and the pyramid constructed over it. It appears that the tomb construction was not begun until after the ruler was dead and that the pyramid was a monument to the deceased.

NOTE

For the reader's convenience the drawing of the center line section has been enclosed separately at the end of the volume. Much of what is said in the report will be understood better if this drawing is unfolded and kept open and nearby for easy reference.

ABBREVIATIONS

MT = Miscellaneous Text (glyphs)

Str. = Structure

73 = Str.5D-73

T.R. 15 = Tikal Report # 15 (in preparation)

117A/21 = Operation 117, Sub-operation A, Lot 21

254 m. = 250 meters above sea level

GD = Greatest dimension

T = thickness

W = width

H = height

D = diameter

VOLUME 1 STRUCTURE 5D-73

FIG. 2 ISOMETRIC RECONSTRUCTION, STR. 5D-73

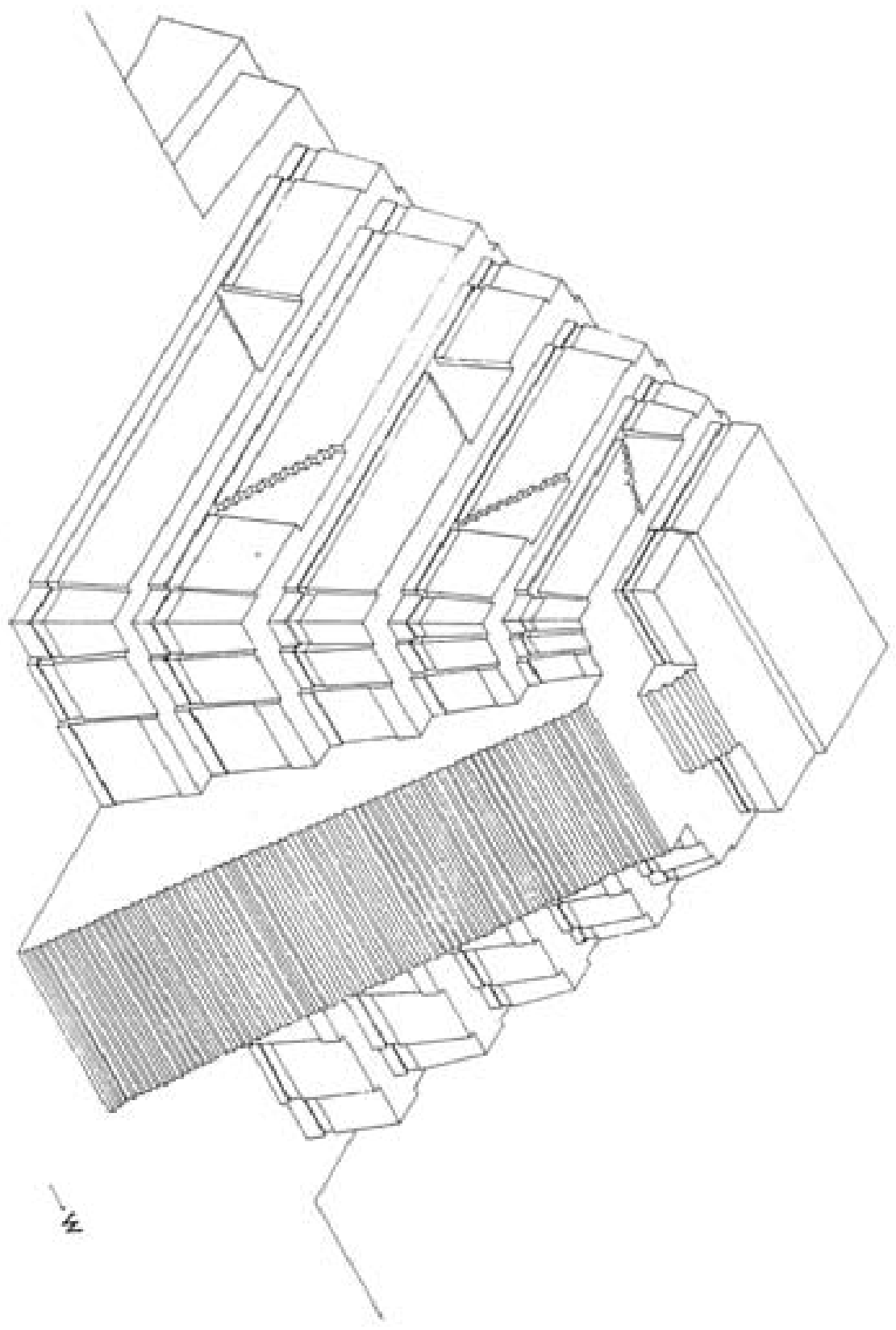

M

1

INTRODUCTION

Justification of the Excavation

Str.5D-73 was selected for excavation because it was a large Late Classic pyramid which did not have the customary temple building or even the remains of a low masonry building wall on its top (Fig. 2). Some Late Classic Tikal pyramids were never intended to support masonry temples or any buildings at all (Coe, 1965, p. 147), but these are of a specialized variety (Twin Pyramid Complex pyramids, Photo 1). Other varieties of pyramid or mound, i.e., Str.5D-37 (Figs. 4, colored green) (T.R. 14), perhaps did support a wooden, thatch roofed ceremonial building; but, again, this is a different variety of "pyramid". In its proportions Str.5D-73 is similar to Temples I (Photo 2), and III, and Str. SC-49 (Loten, personal comm.); it is a definite variety of pyramid which, at Tikal, always sustains a temple of masonry walls and vault.

For the above reason, Dr. Linton Satterthwaite was interested in having the top of the pyramid excavated. He had worked with this problem at Piedras Negras and wished to see if the Late Classic Tikal Maya also had major pyramids surmounted with temples constructed wholly or partially of wood.

This same interest, in addition to the fact that on the

walls of Temple II and elsewhere there are what appear to be representations of pyramids surmounted by wooden and/or thatched roofed temples (Fig. 3), made the excavation of Str.5D-73 seem worthwhile to Dr. William Coe. He thought, since Str.5D-73 is just about 25 m. away from Temple II, that some of the Temple II graffiti might depict Str.5D-73 with a wooden temple.

The tomb was excavated in an attempt to provide a date for the structure. There was a possibility that Str.5D-73 lacked a temple because the pyramid was a "terminal Tikal" construction, i.e., it was built just before Classic Tikal collapsed.

Location

Str.5D-73 is approximately 25 m. south of the south side of Temple II (Fig. 4). Str.5D-73 faces north looking onto the south side of Temple II and is the westernmost structure touching the Central Acropolis palace complex. Str.5D-73 is the only temple-pyramid on the south side of the Great Plaza.

Previous Mention and Excavation

Sometime after the completion of the structure, unknown persons cut a tunnel 10 m. back into the core of the pyramid, presumably in search of caches or burials (see p. 107).

Modesto Mendez "discovered" the ruins of Tikal in 1848

and spent about a week there. Despite his admission of having hacked his way through at least one temple there is no reason to believe him to have been responsible for the intrusion into Str.5D-73.

Tikal was visited by Dr. Bernoulli in 1877. He died on his way home; and, unfortunately, his notes have not been preserved (Maudslay, 1889, p. 44).

In the second half of the 19th century, a group of fugitives from Yucatan settled in Tikal. According to Maler, "they raged for years quite undisturbed among the treasures of the grand old ruined city" (1911, p. 33). This looting is mentioned because such a group is another possible, though not very probable, suspect for the damage to Str.5D-73.

In both 1881 and 1882, Maudslay spent one week at Tikal making a map of the larger buildings and taking notes. His rough plan (Fig. 5) clearly shows Str.5D-73 in its proper position, i.e., across from Temple II (Maudslay, 1889, Vol. III, plate 67). This map is accurate enough to include the steep drop-off on the west side of the basal platform. Maudslay gives Str.6D-73 a small case letter, "Temple f", whereas the five major temples receive capital letters. No ground plan of 73's "temple" is given, but the pyramid is shown as having ruins on top (see p. 7) in the same manner as the ruined buildings of the Central and North Acropolises. Four pyramid terraces are indicated in a conventionalized manner in broken line.

Maudslay did extensive clearing all the way from Temple I past Temple III. Str.5D-73 was just on the south edge of this clearing and in all Maudslay's photographs is still covered by Jungle growth and not clearly discernable (Maudslay, 1889, Vol. III, plate 68a).

Maudslay only mentions his Temple f on one occasion and gives no description of it. It is difficult to determine exactly what status Maudslay gives to 73; because, although it only rates a small "f" and no description, he clearly equates it approximately with the five major temples (Maudslay, 1889, p, 38).

In 1904, Maler visited Tikal and became the second explorer to mention Str.5D-73. Maler in fact seems to have climbed to the top of 73, for he mentions the fine side view of Temple II which may only be seen from the top of 73.

Closely adjacent to the south side of the Great Temple II rises the not inconsiderable pyramid of a neighboring temple. This pyramid has a stairway on its north face, for the facade of its temple faces north, that is, it faces the right wing of Great Temple II. Like almost all the great temples of Tikal the temple proper occupying the platform had the typical division into three apartments. Unfortunately it is now almost total ruin. From the platform of this pyramid an excellent, strictly profile view of Great Temple II can be had, which I recommend to a future visitor. (Maler, 1911, p. 32)

That the pyramid he is talking about is in fact 73 is shown by his description of its position relative to Temple II and its north-facing orientation. But, by the way in which this description is phrased, it appears that Maler could not or



Photo 1 Str.4E-36, one of the "Twin Pyramids".

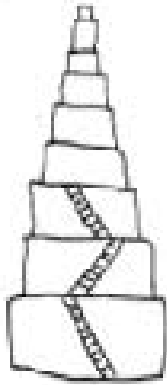

a

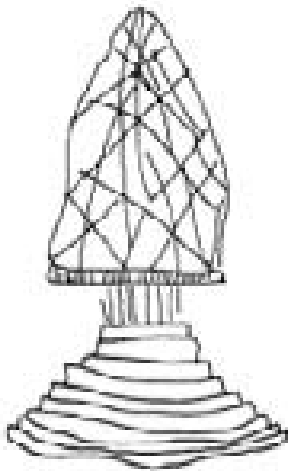

b

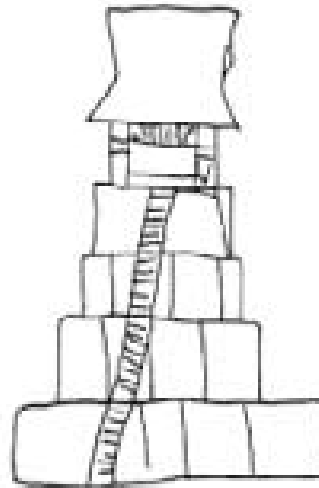

c

Fig. 3 Graffiti at Tikal, a, possibly depicts 'step-insets'; b, wooden thatch roofed 'temple'; c, terraced masonry pyramid with wooden (?), thatched temple, may represent a Str.5D-73 type

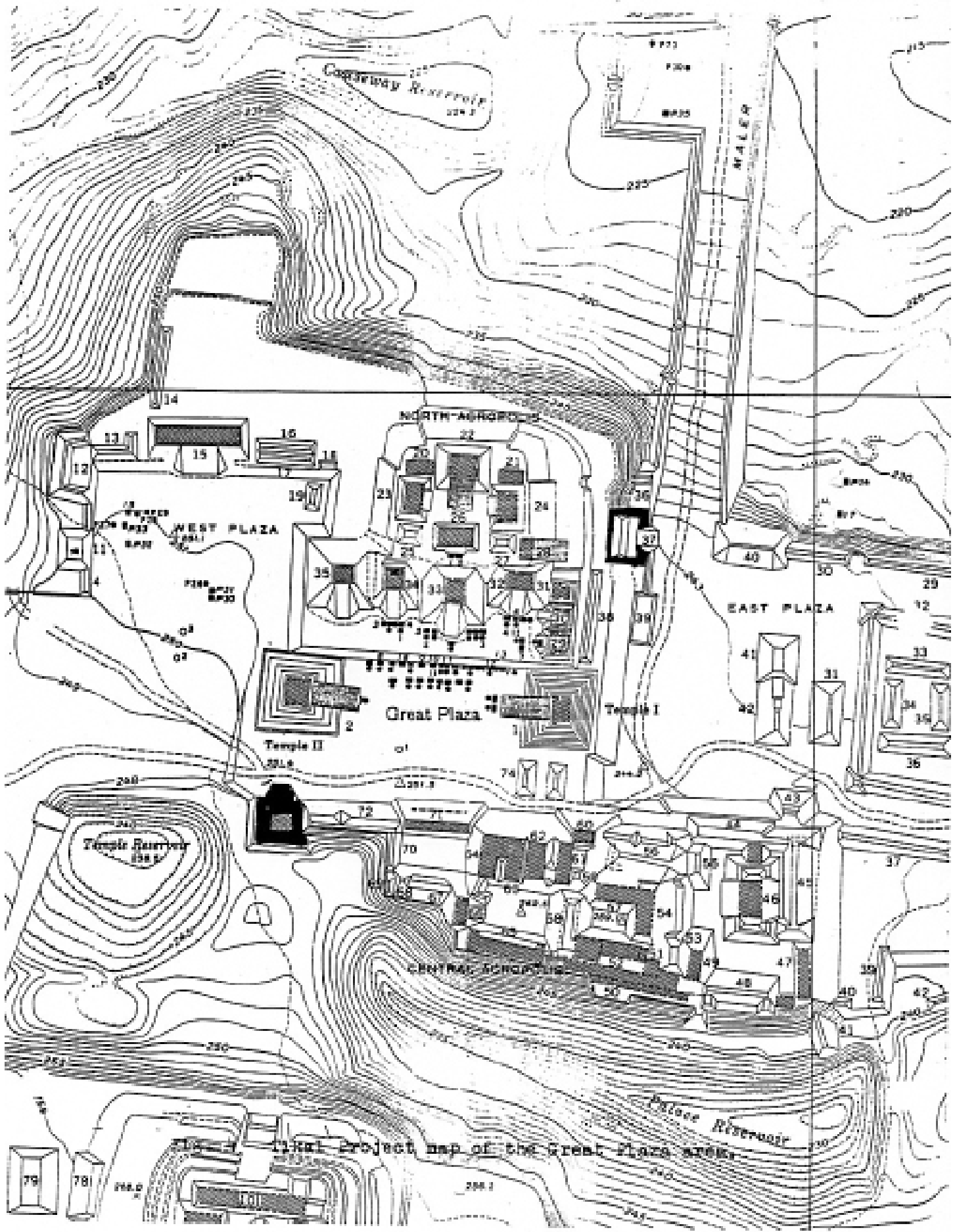

Final Project map of the Great Plaza area.



Photo 2 Str. 5D-1, Temple I

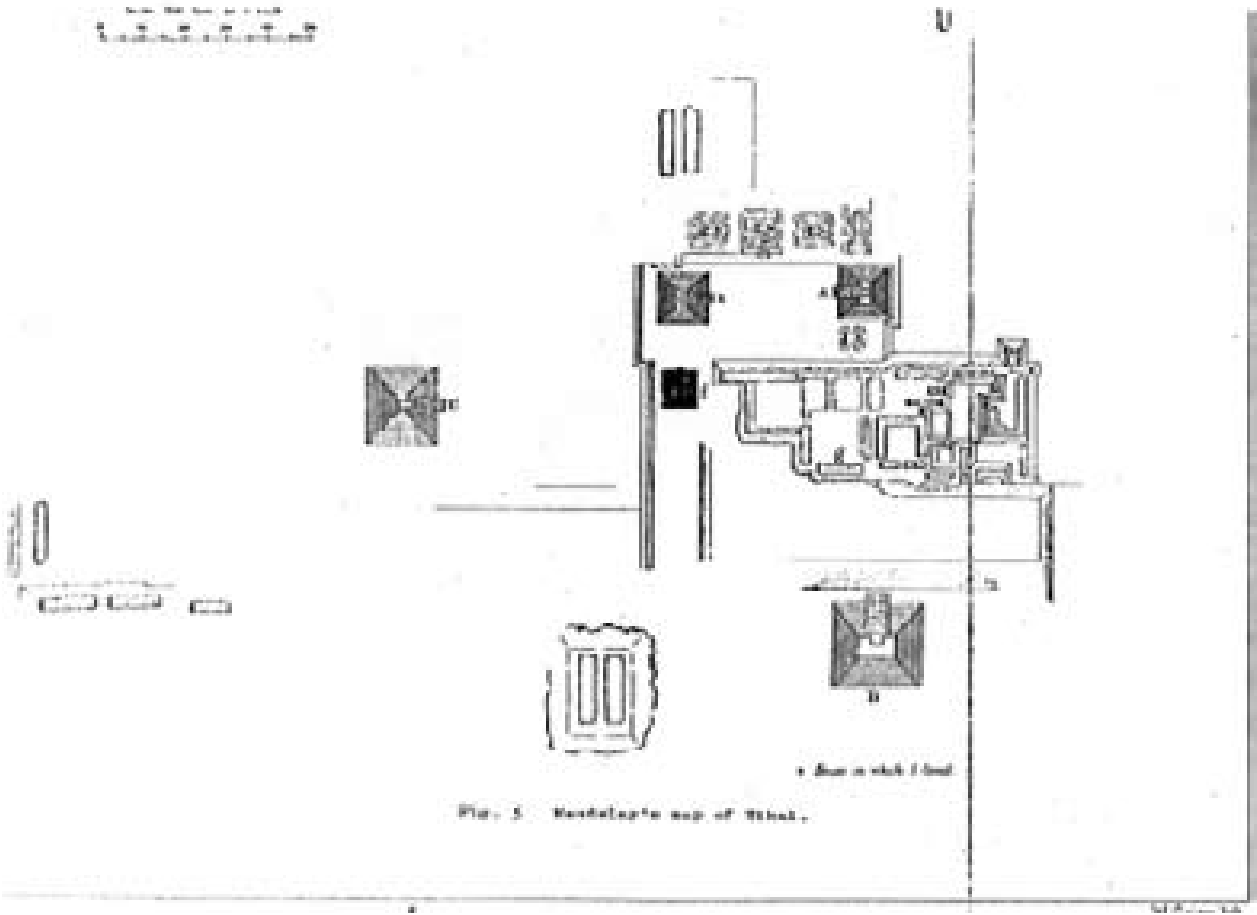

Fig. 5. ... of ...

did not observe the actual stairway. He states that the stairway is on the "north side, for the facade of its temple faces north". When this writer first saw 73, stair stones were clearly visible, as was the general shape and position of the stair. It may, however, be presumed that to Maler a stone of certain dimensions and position which to us today says "Tikal, Late Classic stair stone" was probably mute. An inconsistency immediately arises--how could Maler tell that the temple faced north if the temple was almost in total ruin and if he could not pick out its stairway? It seems that "total ruin" to Maler was not as total as we might suppose, because he states that the temple (evidently) was in a good enough state of preservation to discern three "apartments" or rooms. Was Maler reading this interpretation into an unintelligible mass of rubble because all the other temples in the vicinity, pyramids of similar proportions which clearly had large temples on their tops, had three rooms? Another question is, did Maler himself climb 73 and observe the view of Temple II or did one of his workmen? Many of these questions the writer cannot answer. I believe the answer perhaps might be found by comparing Maler's descriptions of other Tikal structures with what is actually present in an attempt to determine approximately how accurate his descriptions are.

To further complicate matters, Maler then goes on to mention that there is another temple just to the west of

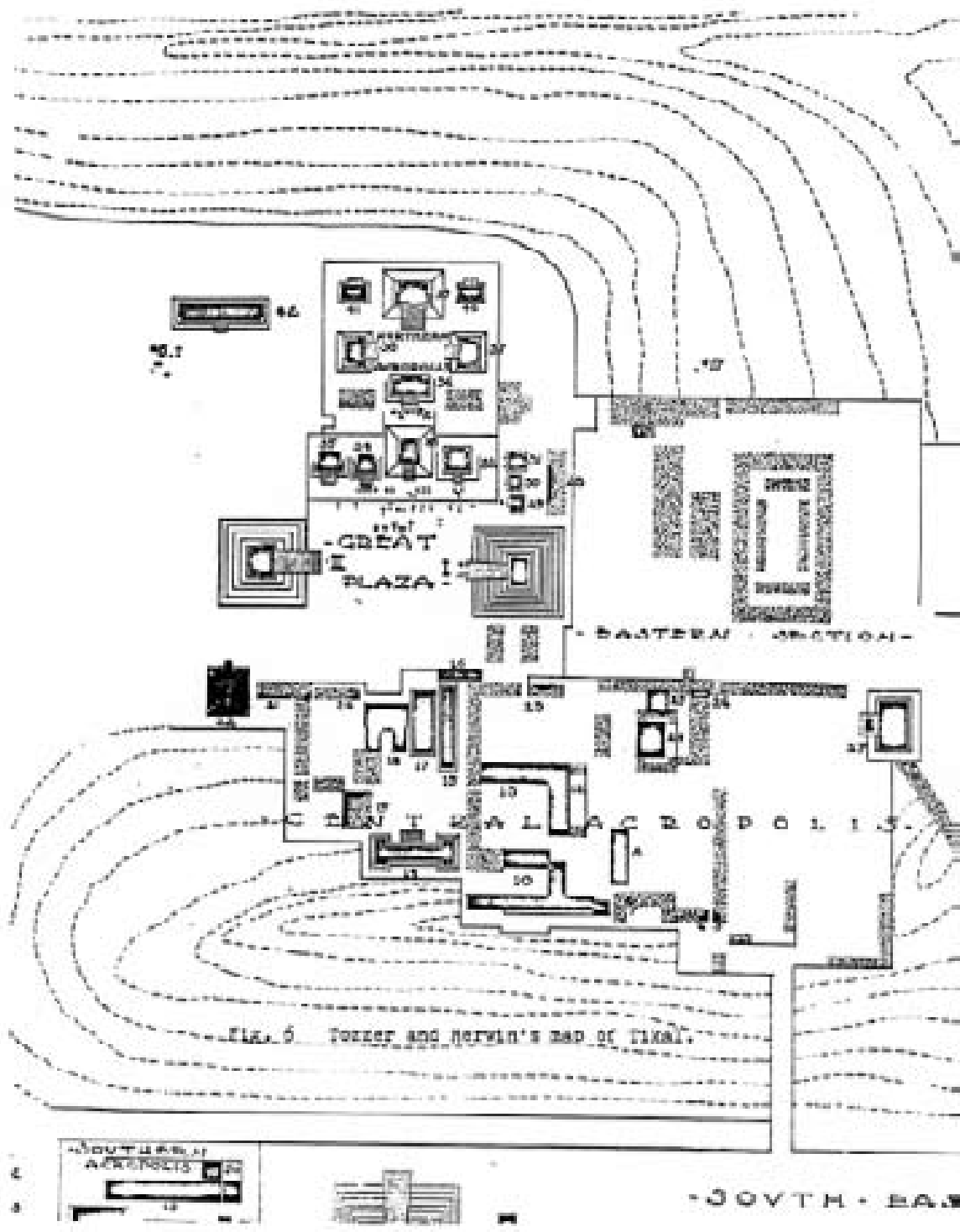

Fig. 6. Temple and Naxos's map of Naxos.

Str.5D-73 (Maler, 1911, p. 32). This is obviously a result of his having mixed up his notes, because there is no such second temple. It is unfortunate that Maler did not send his plan of Tikal to the Peabody Museum, Harvard.

Another explorer to visit and study Tikal was Tozzer. He helps clear up the question of the Maler's "west pyramid" by stating that he could not find the second temple to the west. Tozzer clearly equates Maler's description of the first temple-pyramid with what is now labeled as Str.5D-73.

Structure 22, just west of the western projection described above, is of the temple type. It is almost exactly south of Temple II. Maler ... mentions a second temple to the west. This could not be found. (Tozzer, 1911, 116)

In the sketch map made by Tozzer and Merwin (Fig. 6), Structure 22 (Str.5D-73) has a stylized, solid-black representation of a multi-roomed temple (Tozzer, 1911, Plate 29). There is no indication from the text that Tozzer or Merwin climbed to the top of "their" Structure 22. Tozzer is usually very careful about mentioning preserved masonry; thus, Tozzer probably crowned the drawing of the pyramid with a temple because of Maler's description and because he presumed it should have had a temple building.

Previous Investigation by the Tikal Project

Between 1957 and 1959 the Great Plaza quadrant was mapped by J. E. Hazard, N. Levine, and R. F. Carr. On their map (Fig. 4) (Carr, 1961, Great Plaza) the map symbol for

exposed walls, i.e., the remains of a temple, is shown on the top of Str.5D-73. The question is: did the map-maker actually climb to the top and see exposed walls or the remains of a collapsed building; or, seeing the type of pyramid it was, did the map-maker simply assume that there was a temple on top? Since climbing 73 is a tollsome task even on a cool, dry, day the map-maker was either familiar with the two earlier maps showing 73 with a temple or else just presumed that there should be a temple building on top.

In the summer of 1965, Andrew Nagy of the Tikal Project was assigned to make what architectural drawings he could of Str.5D-73 as it stood, without excavation. He was also supposed to look for remains of a temple on top of the structure. The only excavation he undertook was of the two front corners of the first terrace of the pyramid. He and his workmen chopped down a few trees, especially around the west side and at the back of the basal platform. A few trees were taken off the top of the pyramid and on the stairway; but, when the author began clearing, most of the top was still covered with trees. The author cannot remember more than two small stumps on top, and was unable to ascertain exactly how much debris had been removed. Nagy states that no excavation was done on the building platform and that the building platform step-up was visible by scraping away a few leaves. Nagy also states that absolutely no masonry debris was present and that he did not remove any large stones from



Photo 3 SCF.5D-73. front (northwest) corner before bushing.

the top of the building platform. He did draw a north-south and east-west section of the whole pyramid; however, none of these drawings were utilized by the writer because they were not based on excavation.

No other work was done on or around 73 by the Tikal Project. All those (such as Dr. Satterthwaite) who climbed to the top of 73, stated that they were never able to see any remains of a masonry structure. The excavations undertaken by the author were to look for the minute remains of wall stubs or remains of floor turn-ups to a ripped out wall that would indicate the previous presence of a building.

Appearance of the Mound Before Excavation

Almost all the architectural features of the pyramid were buried beneath entangled tree roots and a luxuriant layer of leafy geranium-like plants (Photo 3). The width and extent of the front stairway was visible even before clearing, although at first it looked as though the Park road had removed the bottom steps. One tremendous tree grew about one-third of the way up the stairway, causing an unnatural bulge there; numerous sections of the stairway had been uprooted but leaving the step stones in approximately their correct relative positions. A bit of the stair side-wall masonry was visible on the east side before bushing and on the west side after bushing.

Before bushing, some pyramid facing masonry was visible

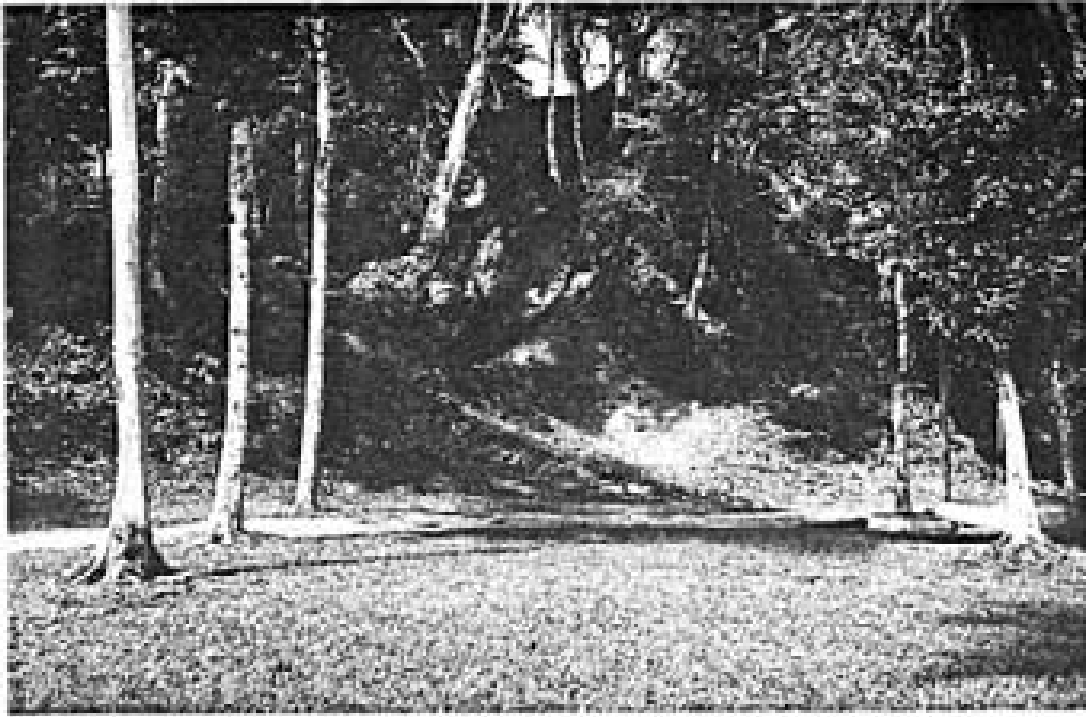

Photo 4 Str.5D-73 as seen from the Great Plaza, before excavation.



Photo 5 Rear of Str.5D-73 after bushing but before excavation.

on the upper four terraces next to the east stair side-wall. After bushing, facing masonry was visible on the top terrace on the south and west sides, approximately on the centerline. Except for the facing masonry of the first terrace, which was buried by fallen debris and thus protected, the facing masonry of almost all the rest of the pyramid had been peeled away by tree roots. (Photos 4, 5, 9).

Considering its exposed position, a considerable amount of finish masonry remained on all four sides of the building platform and building platform stairway. Even before bushing and excavation much of this masonry was visible. Also, clearly visible on the top of the building platform, was a definite step-up, dividing the building platform into at least two levels. This may, however, have been somewhat the results of Nagy's previous investigations.

Extent of Clearing

The first problem faced by an excavator is how much of the Jungle growth to remove. If too many trees are chopped down, the fragile masonry will be directly exposed to torrential downpours. Tree roots often hold together a great part of the building. In excavating in the East Plaza, however, the author found that the more trees that are removed the better. This facilitates taking before-and-after photographs of the structure.

To start with, almost every tree within 20 m. of the



Photo 6 Guatemalan workman excavating tunnel between Strs. 50-72 and -73.



Photo 7 Tunnel between Strs. 50-72 and -73, lower level.

base of the pyramid was cut. Their removal would not endanger the structure and would greatly facilitate the work to come. Several trees which obscured the view from Temple II were removed. The top of Temple II's pyramid was the only place from which one could get a full frontal photograph of 73 (Photos 9, 10), especially of its building platform (Photos 33,34). A tremendous tree growing on the stairway was removed because the centerline tomb tunnel might cause it to collapse. All the trees on the edge of the top of the building platform were left to preserve the pyramid. During the period of excavation, about three trees toppled over after heavy rain storms.

Extent of Excavation

Looking for the tomb only necessitated the digging of one centerline tunnel. On the front of the structure, the sequence of insets and outsets had to be known. Presuming bilateral symmetry, only one half of the front was cleared completely. After the northeast corner of the base of the pyramid was found, and since the point of juncture between the stair side-wall and after the pyramid face was uncovered by excavation, the author moved in with a tractor equipped with a front-end loader and a back-hoe (trench digger) (Photo 6). During after-hours and on weekends he was able to completely excavate the portion visible. The writer had used one of these machines before and no damage



Photo 10 The front of Str.(D-?) before excavation but after
bushing, as seen from the top of Temple II.



Photo 11 The front of STR. 5D-73 after complete excavation, as seen from the top of Temple II.

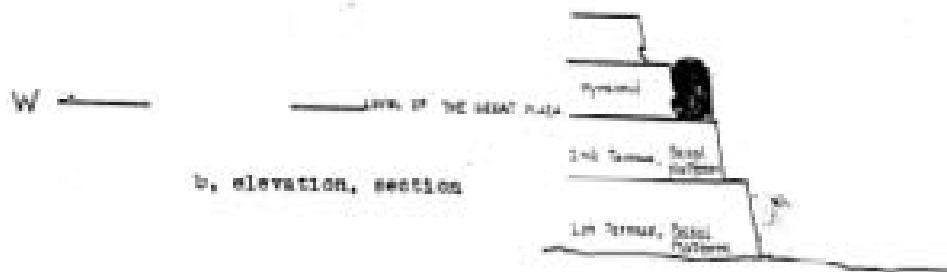
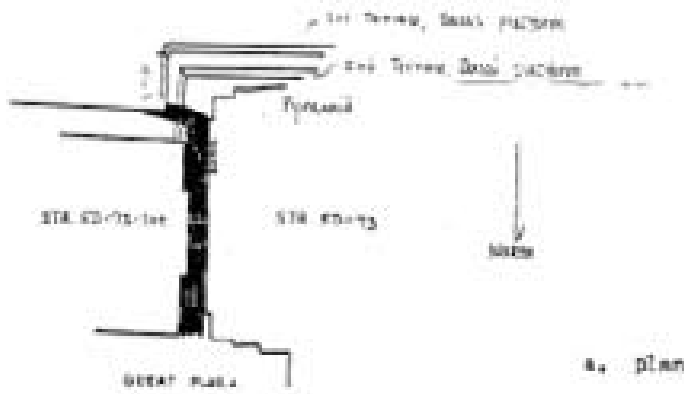

Fig. 7 Plan, section, and elevation of tunnel system between STR. 5D-74 and STR. 5D-73.

was done to the structure; the last few inches were always left for the workmen to remove by hand. This machine was also used to make numerous excavations on the sides and back in order to determine the outline of the basal platform. It was extremely useful and saved hundreds of native man-hours of excavation time; for backfilling it was even more indispensable.

After the writer found that there was only a meter or so between the east side of Str.5D-73 and the west side of Str.5D-72, he decided to tunnel between the two, north to south (Photo 7). This would completely uncover the entire east side (22 m.) of 73, as well as the whole west side of this level of 72. There were several reasons why this expenditure of time was very important. First, this was the only part of any terrace of the 73 pyramid which was protected enough by fallen debris to be in a good state of preservation. Secondly, a tunnel at this point would facilitate recording to a great extent. The third and most important reason was to try and see if Str.5D-73 had a unique type of "step inset" (Fig. 18), found so far in all Mayan architecture only on Temple I (see p. 82). This would be the only part of 73 where this feature might be preserved. Finally, it was important to determine whether 73 had been built at the same time or before or after 72.

The tunnel system is rather complicated and may best be visualized by looking at the diagram (Fig. 7). Its prin-

cipal feature is a tunnel going 17 m. north-south from the northeast corner of 73, parallel to the east side of 73. The "floor" of the tunnel is the "Great Plaza" level on which 73 is built; one side of the tunnel is the east side of 73; the other side of the tunnel is the west side of 72, a palace which is only 1 m. away from 73. This tunnel cuts through the debris that has fallen from the sides of 73 and 72. As these two structures are close together at this point the dirt piles up to a maximum of 4 m. Midway on this tunnel a shaft goes up through the 4 m. of overburden; this is on the line of the east-west centerline section.

The front of 73 is built on the Great Plaza; the back of 73 is over 5 m. off the ground, resting on a basal platform. Consequently, the north-south tunnel comes out at its south end 5 m. above ground level on the top of the 2nd terrace of the basal platform. To investigate the relationship between Str.5D-73 and the adjacent Str.5D-72, another tunnel system was dug through collapsed debris and made to connect with the first tunnel. The new tunnel was begun on ground level on the east side of the basal platform going north 7 m. until the east-west-running south face of the Str.5D-72-1st basal platform was reached. From here a shaft was dug 4 m. up and to the west, following both the south face of 72 and the east face of 73, i.e., the shaft was traced to the interior corner of the two platforms. This shaft of course ran into the north-south tunnel at the Great Plaza level.

The writer was fortunate in that, even with torrential downpours, there was never any part of the tunnel that collapsed.

All four corners of the pyramid and basal platform were dug out. None of the upper corners above the first terrace was dug, because none was preserved (except all the way up, on the building platform). There was extensive excavation at the pyramid's base for the east-west and north-south centerline trenches.

On top of the pyramid, the entire front of the building platform was cleared. Then, very carefully, all the humus but not a single stone fragment was removed from the top of the building platform (Photo 33). After the two building platform step-ups had been recorded and no wall stubs or floor turn-ups were found, (at the suggestion of Dr. Coe), the whole top of the building platform was quickly dug through, to look for a cache. A centerline trench revealed several interesting constructional features, but no cache was found. Unfortunately there was neither time nor labor available to remove the building platform (carefully) layer by layer all the way to the pyramid top. The centerline sections show somewhat the extent of excavation (Figs. 19a , 19b).

After the author left in January, 1966, Rudy Larios did the plan and elevation. He also attempted to follow the floor on which Str.5D-73 was built over to the south side of Temple II,--an effort which was unsuccessful due to weather-

ing and the fact that the Park road was constructed between the two structures. He did some additional excavation on the back of 73 to determine the positions of the rear outsets and to solve complications uncovered by this writer in the rear basal platform.

The writer worked on 73 from mid August, 1965 until mid January, 1966.

Standards of Recording

The plan was done using a transit and will eventually be related to the Martinez Grid System of the North Acropolis. All elevations were established by the use of a level from bench marks in the Great Plaza. Most of the drawings were double-checked and should be extremely accurate; all drawings were done by the writer except for the plan, elevation, and two detail-drawings done by R. Larios.

Acknowledgements

For his work at Tikal, the author wishes to thank Christopher Jones for all the assistance he rendered him. He was present up to the day the first objects came from the tomb. Rudy Larios was also of great assistance in making the plan and elevation when the writer had to return to school in February. The National Science Foundation through Harvard College provided enough money to enable the author to stay and excavate this structure. Miss Penelope Orr proofread

the manuscript and made it infinitely more readable. Dr. William R. Bullard contributed numerous helpful suggestions.

All the architectural drawings were done by the author except for Figs.16-18, 20-23 which were done by R. Larios. All the drawings of pottery and technical description thereof were done by Virginia Greene.

Photographs were taken with the following equipment:

Photographs #	were taken by Dr. William R. Coe.
Photographs #	were taken by the author with a Rolliflex.
Photographs #	were taken by the author with a Rolliflex and high speed Ektachrome
Photographs #	were taken with Kodacolor X.
Photographs #	were taken with Kodachrome II.
Photographs #	were taken with a 35 mm. lens on a Lerca M-3 (35 mm.)
Photographs #	were taken with a 135 mm. lens on a Lerca M-3 (35 mm.).
Photographs #	were taken with a 65 mm. or 135 lens-heads on a Lerca M-3 equipped with a reflex housing and focusing bellows.

Operation numbers

The tomb and centerline tomb tunnel were dug under Op. 117A. Op. 117B was concerned with the building platform; and

117C covered general exterior excavations to determine the positions of corners, outsets, etc. What little work was done on Str.5D-72 was under Op. 117D.

Limitations

The Tikal Project's ceramicist has not yet completed his study of the pottery from Bu.196 nor has a complete evaluation of the sherds found in the pyramid fill been made. The skeletal materials in the tomb, likewise, have not yet been studied by the appropriate specialist. Many of the offerings found in the tomb have not yet been catalogued or drawn by the Lab staff; however, considering the volume of material uncovered, this is not surprising.

EXCAVATIONS

PRE-STR.5D-73 TIME-SPANS

The Great Plaza, the North Acropolis (T.R. 12), and the Central Acropolis (T.R. 15) all had their beginnings long before the erection of Str.5D-73. The North Acropolis was more or less in its final form, as was probably (to a lesser extent), the Central Acropolis. It is not known for certain whether Temples I and II were built yet (see p.).

PRE-STR.5D-73: FLOOR A

The earliest feature uncovered during excavation was a smooth, hard-surfaced floor found below Burial 196. When first uncovered the writer thought it was merely the floor laid by the tomb builders to cover over the rough cut they had made. The floor was traced below all four walls for a few centimeters. On the east side it was followed 1.90 m. eastward under and beyond the east wall of the tomb (Fig. 9) After the first 1.20 m., the fill of the tomb wall ended and the fill of what was presumed to be that of the Great Plaza was entered. The floor continued under the Great Plaza (7) fill. This means that the floor antedates the tomb cut as well as the previously existent construction on which the 73 pyramid was built.

There was not enough time to get sherd samples from

within or below the floor. There is no way to date the floor.

APPEARANCE OF THE STR.5D-73 LOCATION
PRIOR TO THE CONSTRUCTION OF STR.5D-73

Evidence For or Against an Earlier Structure

There was only one poorly-understood hint that there had been an earlier structure below the mound which is visible today. This was the presence of a mason's stairway deep within the fill of the pyramid which rests on a lower mortar layer than the two front mason's stairs. The front two mason's stairways are clearly part of the final phase of 73. The mason's stairway under consideration is well within the pyramid and not covered by fill of the projecting finish masonry stairway as are the two northern mason's stairways (see p. 68).

Also, the rough "floor" on which the front three construction stairways rest abuts the southernmost mason's stair. In addition, part of the southern mason's stair has been ripped out (see p. 71).

Evidence to negate this being the finish-masonry stair of an earlier pyramid was that no smooth, hard-surfaced, floor turned up to its base. What abuted its base was a rough layer of mortar. This mortar layer may have been intentionally laid or it may just be mortar dropped by the masons and trampled underfoot as the final pyramid was built.

There is no finish plaster on the south mason's stair, even though the stones are relatively well cut and placed. (Dr. William Coe does not believe there is evidence of an earlier structure). It is possible that this is indeed a mason's stair after all but a mason's stair for an earlier pyramid. This would explain why there was no floor turning up to it. The pyramid and finish floor which would have covered it would have been completely ripped out (see p. 71) just prior to the erection of Str.5D-73-1st.

If there were an earlier structure there may have been an earlier tomb; or, if there were an earlier structure, then Bu.116 may belong to it and not to the Str.5D-73 which is currently visible. In the latter case there is the possibility that a tomb also existed for the visible final stage Str.5D-73. If there were such a tomb, it either was removed by the robbery tunnel or is still awaiting discovery below where the robbery cut ceased.

THE BASAL PLATFORM

Most of 73's base appears to have been built on the Great Plaza, especially the northeast quarter. On the entire back side of 73, on about 1/3 of the east side, and on almost all the west side there was a two terrace basal platform (Piss. 21, 22). Temple I was situated in a similar position with the front built on the Great Plaza and the back built on a basal platform which rose from the East Plaza.

The question is, was the building platform built specially for Str.5D-73; and, if so, what was the boundary of the Great Plaza just prior to the construction of the basal platform?

The following discussion is based on the presumption that Str.5D-73 was constructed as a unit and was not rebuilt.

The west basal platform of Str.5D-72-3rd (?) (Fig. - -) (the earliest of three stages of this palace uncovered) probably created the west limit of the Central Acropolis.

It appears that the exterior 10 m. or so of what forms the basal platform of 73 was built specifically for 73, because the basal platform fits perfectly the plan of the pyramid and obviously appears to have been designed with 73 in mind. The plaza floor on which 73 was built was at an elevation of 250.31 m. at the foot of the front steps of 73, and 250.12 m. where cut through for the tomb. The centerline elevation of the south base of the pyramid is 250.60 m. which makes it difficult to claim that the plaza floor runs all the way south to cap off the finish masonry of the basal platform. As a pure guess, the author postulates that to the south and west Pre-Str.5D-73: Floor B would have turned over to a terrace facing for the respective edge of the Great Plaza (Fig. 26), probably about 5 or 10 m. short of where the basal platform limit is now. Thus, the basal platform seen today would be just a slight extension and rearrangement of the Great Plaza boundary built to receive Str.5D-73.

Furthermore, the tomb was cut through the plaza floor. It seems strange that the Mayans would first build up this area for the basal platform and then immediately cut down to build the tomb. The fact that there was a tomb cut suggests that at least this area had already been built up as part of the Great Plaza before it was decided to build the tomb and pyramid. One easy, but time-consuming method to solve this problem would have been to have continued the centerline tunnel southward until Pre-Str.5D-73: Floor B came to an end and/or to have started a centerline tunnel going north at the level of the base surface sustaining the basal platform. Hopefully, this tunnel would soon have run into the facing for the pre-73 Great Plaza south face.

The final phase of Str.5D-72 was built after Str.5D-73 (Fig. 25). An earlier phase of 72 was built on the same floor as 73. A still earlier phase of 72 was built before 73.

It is not known whether either Temple I or II was built before or after Str.5D-73. Because Temple I is similar in many respects to 73, it should eventually be possible to hazard a guess as to which is earlier on the basis of stylistic analysis. Evidently Temple II was built at about the same time as Temple I (Wm. Coe, 1965, p. 41). If the relative date of Temple I - Str.5D-73 were known then an approximate relative date for Temple II - Str.5D-73 might be known.

In 1966, an attempt was made by R. Larios to connect the floor sequence of 73 with that of Temple II by digging a

trench between the two structures. Unfortunately, the floors were not very well preserved, and the Park road runs between the two structures. However, by knowing how many and what kinds of floors turn up to the two structures, in the future some sort of relative date might be guessed.

STR.5D-73 TIME-SPANS

Below is a list of the Str.5D-73 Time-Spans and construction stages which were uncovered by the limited excavations undertaken. It is based on the assumption that Str.5D-73 was a one period construction.

STR.5D-73: TIME-SPAN 9	DESIGN PHASE
STR.5D-73: TIME-SPAN 8	A MAYAN NOBLE DIES
STR.5D-73: TIME-SPAN 7	CONSTRUCTION OF THE TOMB
Construction stage 10	Digging the tomb pit
Construction stage 9	Bench fill
Construction stage 8	Tomb walls erected
Construction stage 7	Wall plastered (plastered to edge of tomb cut)
Construction stage 6	Front put on bench
Construction stage 5	Tomb floor and bench plastered
Construction stage 4	Body and offerings placed in tomb
Construction stage 3	Cloth stretched across burial at wall top level
Construction stage* 2	Vault
Construction stage* 1	Wooden pole roof

STR.5D-73: TIME-SPAN 6	CONSTRUCTION OF THE PYRAMID
Construction stage 12	Flint and obsidian bearing fill
Construction stage 11	Non-flint fill to floor cut
Construction stage 10	Mason's stairway #4
Construction stage 9	Rip-out of part of mason's stair #4
Construction stage 8	Rough layer of mortar turning up to rip-out
Construction stage 7	Mason's stair #3
Construction stage 6	Mason's stair #2
Construction stage 5	Mason's stair #1 and Problematical deposit 171
Construction stage ⁺ 4	Pyramid finish masonry
Construction stage ⁺⁺ 3	Building platform
Construction stage 2	Final stairway
Construction stage 1	Building platform stairway
STR.5D-73: TIME-SPAN 5	FLOOR IN PASSAGEWAY BETWEEN STR.5D-73 and 72
STR.5D-73: TIME-SPAN 4	PLAZA FLOOR WHICH TURNS UP TO EAST & NORTH SIDE OF 73
STR.5D-72: TIME-SPAN 3	FINAL PHASE OF WEST BUILDING PLATFORM, PLAZA LEVEL
STR.5D-73: TIME-SPAN 2	RENOVATION OF SOUTH BASAL PLATFORM
STR.5D-73: TIME-SPAN 1	TOMB ROBBERY ATTEMPT

Notes on the Sequence of Activity

The above sequence is only a list of the constructional activity discovered by limited excavation and not a list of everything which is thought or known to have gone on. For

instance, it is known from extensive excavations in Str. 5D-33-1st, Str.5D-37, Temple I and elsewhere, that Late Classic pyramids at Tikal were built up terrace-level by terrace-level. After each level was erected, it was covered with a rough to even layer of light colored lime mortar. Str.5D-73 was almost certainly built in this manner; but it is not known where the construction stairways fit into this sequence. Thus, the terrace levels are not mentioned in the list.

There is no time-span allotted for the use of 73, because there is no evidence that the pyramid was ever finished. This is presuming that it was meant to have a masonry temple on its summit.

STR.5D-73: TIME-SPAN 9 - DESIGN PHASE

The writer always likes to set aside one time-span for the "design stage". Large structures such as 73 were not just suddenly put up. There has to have been a reason for expending all the energy it must have taken to raise 73; some sort of plan was probably previously drawn up by an actual architect so that a building was designed and not erected arbitrarily. Numerous examples of what could be architectural sketches are known, most of them graffiti. There are several graffiti which look like preliminary drawings for stelae and (Bullard, 1965, Fig. 4). It even appears that the Mayans had some notion of city planning or at least

plaza planning (*ibid.*, p. 47). For Str.5D-73 there are, of course, no preliminary drawings remaining.

As for why 73 was built, theory and evidence will be presented on page . As for the actual method of erecting 73, a great deal is known from intensive excavation of Temple I and Str.5D-33-1st. The writer did some work on Str.5D-33-1st and investigated the problem concerning the sequence of construction in Str.5D-37. In this report only general constructional trends will be noted, because there was neither time nor any special need to look for the detailed constructional sequence in the 73 pyramid. In 73, the emphasis was on the burial and on the top of the building platform.

There is no way of knowing whether the design phase occurred before the ruler died or not (see p.).

STR.5D-73: TIME-SPAN 8 - DEATH OF A MAYAN NOBLE

Although it is a known fact that the Mayans sometimes planned and built their burial temples before death (Temple of the Inscriptions, Palenque), it appears that the usual practice was to erect the pyramid just after the body had been interred. In the case of the Palenque mausoleum, there was a well built passageway allowing convenient access to the burial chamber after the pyramid was finished. In 73 there did not appear to have been any way for the body to have been interred after the pyramid was built; however, excavation was not extensive enough to find such a tunnel en-



Fig. 3. Exterior section through the roof.

SEE FIG. 1A, FOR THE EXTERIOR ILLUSTRATION
 THE SUBJECT OF CONSTRUCTION OF THE TOMB.

trance even if it had existed.

One possibility is that the tomb pit was dug and that the tomb walls were erected; then the tomb remained in this open condition until the ruler died. (From evidence within the tomb it is known that the burial took place before the vault was erected). The author doubts that the tomb pit remained open in this manner because no provision for drainage was found.

Another possibility is that the tomb-to-temple sequence was continuous with someone being sacrificed and put into the tomb. There is no positive evidence for this and a great deal of negative evidence (see p.).

The author's belief is that no building activity began until some Mayan in authority died, after which the tomb was built with the pyramid covering it immediately after the burial ceremonies.

STR.5D-73: TIME-SPAN 7 - CONSTRUCTION OF THE TOMB

Construction Stage 10: Digging the Tomb Pit

Before the tomb pit was dug, a decision had to be made as to where to locate the burial temple. Very little, if any, investigation has gone into this question. Was a central location, a sacred location, a practical location or some combination of these or other considerations a guiding factor in the choice?

Constructionally, the first activity was that of digging a large rectangular pit for the tomb (For all the description which follows it would be helpful to look at Fig. 14 on page). It would have been interesting to have intensively investigated the sequence and extent of this operation but there was not enough time. Only two limits of the tomb cut are known; the first limit is the northernmost one. The edge of this cut was found in the centerline tunnel approximately 17 m. south of the front stairway. Here the floor had been cut through, with the cut leading down 4 m. until an old floor was reached. It is presumed that this cut travelled more or less straight down, although the side of this cut was not followed down more than about 10 cm. Instead, as a work-saving method, the tunnel went down diagonally.

The east edge of the cut was followed down from the level of the plaza floor (Pre-Str.5D-73: Floor B) all the way to the bottom of the tomb, just over 4 m. There was an obvious difference between the plaza fill which the Mayan workmen cut through and the fill behind the tomb walls. The edge of the tomb cut was roughly horizontal with a slight slope.

Neither of the other sides of the tomb cut were reached in excavation. It is presumed that the tomb cut was approximately rectangular. It is possible that rough steps were cut into one of the unexcavated sides of the cut. Such steps have been found leading down into other tombs at Tikal (Bu.195 in Str.5D-32). The total area of the tomb cut is presumed to be

4.40 m. north-south, 7 m. east-west and 4 m. down. What happened to all this fill is unknown; it could have been stock-piled nearby for eventual use in the 73 pyramid.

Construction Stage 9: Fill for the Bench

Surprisingly, before the walls were begun, the bench was begun. All the bench fill, with no plastered surface and no facing masonry was put into place. Only then were the walls begun. One aspect of construction that makes this seem strange is the fact that there was no apparent layer of mortar covering the fill to indicate a pause - yet it is known that the bench top was not plastered nor was the bench fronted with finish masonry until all four walls had been erected to their full height and plastered. Unfortunately, this perplexing aspect of the tomb's construction sequence could not be investigated any further because it was discovered just before the author had to leave Tikal and when his workmen were reassigned to newly arrived staff members.

Artifacts

Artifacts from the bench fill were cataloged under Op. 117A, Lot 41. 1 lb. 13 oz. of sherds were found but they have not yet been studied.

Nature of the Plaza Fill Which was cut Through

It appears that it was the Great Plaza, near its south-

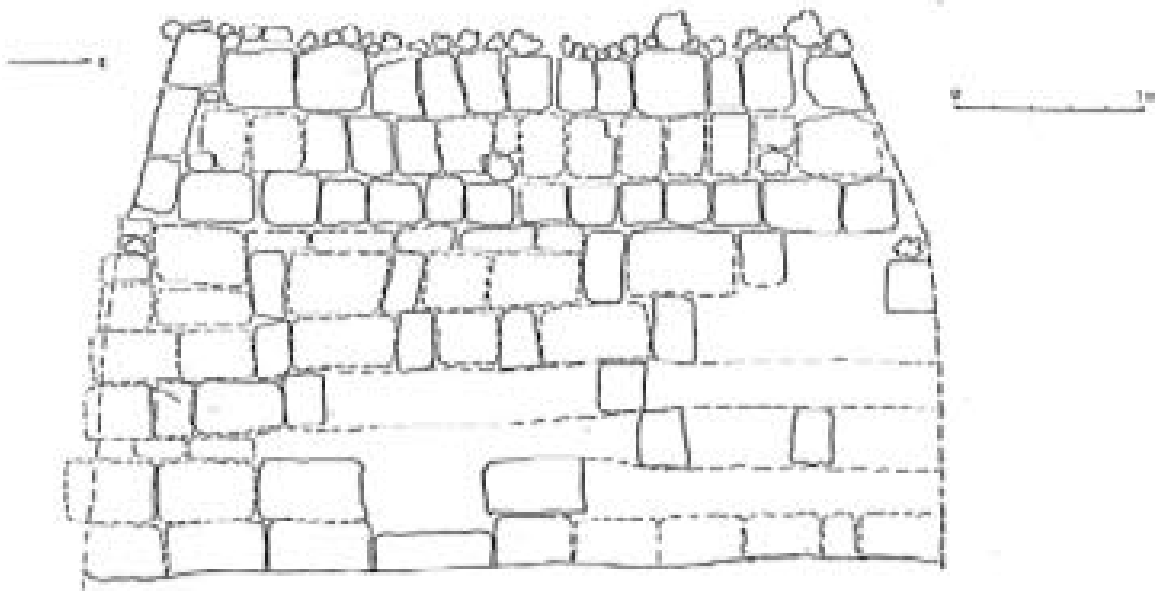

Fig. 10. No. 104, north side masonry detail elevation.

west corner which was cut through to build the tomb. A 4 m. deep section of the plaza fill was exposed when the east side of the tomb out was exposed. The fill was not composed of large stones, but looked like trash and other non-construction debris; the fill was all in lenses of varying thickness (average lens was 5 to 20 cm. thick, memory). These lenses were generally horizontal but on an angle sloping down to the north. Many of the lenses contained numerous small fragments of charcoal.

CONSTRUCTION STAGE 8: ERECTION OF THE TOMB WALLS

One thing which should be kept in mind when the tomb is discussed is its rather unusual "vault". Rather than having a vault slope until there is only a 30 cm. or so gap between the sides and then having a wooden capstone, in Bu.196 the vault only goes up three courses and then is roofed by wooden poles. It is easiest to visualize this by looking at the two cross-sections of the tomb chamber, Figs. 8 and 9.

NORTH WALL

The north wall of the tomb was built directly on Pre-Str.5D-73: Floor A (Fig. 8). The dimensions of this and the other walls are given below:

NORTH Base length = 4.50 m.	Top length = 4.22 m.
	West height = 1.84 m.
	East height = 1.72 m.

SOUTH Base length = 4.52 m.	Top length = 4.26 m.
	West height = 1.60 m. (+ bench)
	East height = 1.50 m. (+ bench)
WEST Base width = 2.26 m	Top width = 1.94 m.
	South height = 1.44 m. (+ bench)
	North height = 1.76 m.
EAST Base Width = 2.28 m.	Top width = 2.08 m.
	South height = 1.46 m. (+ bench)
	North height = 1.72 m.

Except for a few bits and pieces of masonry near the corners, the top three courses had peeled away from the fill and had fallen. In the case of the header stones, only the fronts were sheared off with the butts remaining in place (Fig. 10,). The masonry detail elevations of all the tomb walls were often based on the fact that although the stretcher stones may have collapsed, the butts of the header stones and the easily-discernable mortar course-layers made possible a fairly detailed reconstruction (in broken line), which is an accurate representation of the original facing. Where the wall was too collapsed for a reconstruction, the area is left blank in the drawing.

Where the wall facing had peeled away, it was possible to see that there were no offerings of flint and obsidian in the fill. This is an important fact, because such offerings were profuse in the fill over the tomb's ceiling but were not behind the vault stones (see p. 57). A faint trace of red (cinnabar) could be seen on one of the stones. This coloration apparently occurred when red powder was being sprinkled

on the offerings. There was no attempt to cover the walls with red; and the red that is present is there unintentionally.

The wall was pierced by two beams of logwood (Figs. 9, 10) (see p. 35). One beam penetrated the upper course near each upper corner.

SOUTH WALL

Strangely enough, the south wall did not rest directly on the tomb's base surface but rested on the fill of the bench. At the top of the bench fill, under the final plaster coat (Construction Stage 5), there was no discernable level or layer of mortar marking off the top of the bench fill. The tomb floor-bench-top plaster turned up to the plaster of the south wall just as it did to the other walls. This problem was only investigated in one place, but here the wall merely rested on the fill of the bench.

The stones of the south wall pass by those of the east wall. The southwest corner was too poorly-preserved to determine the sequence here. Traces of red pigment were visible in places where it splashed or was accidentally thrown. Coming from the vault above was a long drip-line showing quite dramatically how wet the vault plaster was when it was applied.

It was over the south wall that conclusive evidence was found that a textile had been stretched over the tomb at wall top level, just prior to the erection of the vault (see p. 45).

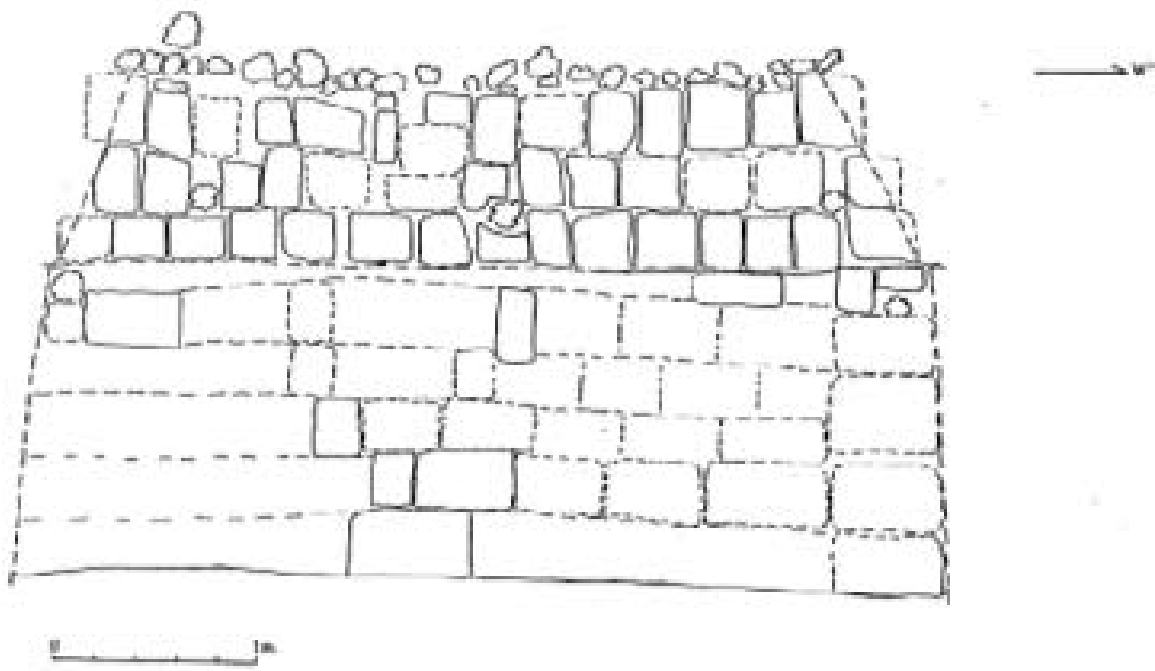

Fig. 11 South side, masonry detail elevation, No. 170



Photo 13 Bu. 196, east side showing excavator's method of entrance, before excavation.

0 1 m.

N

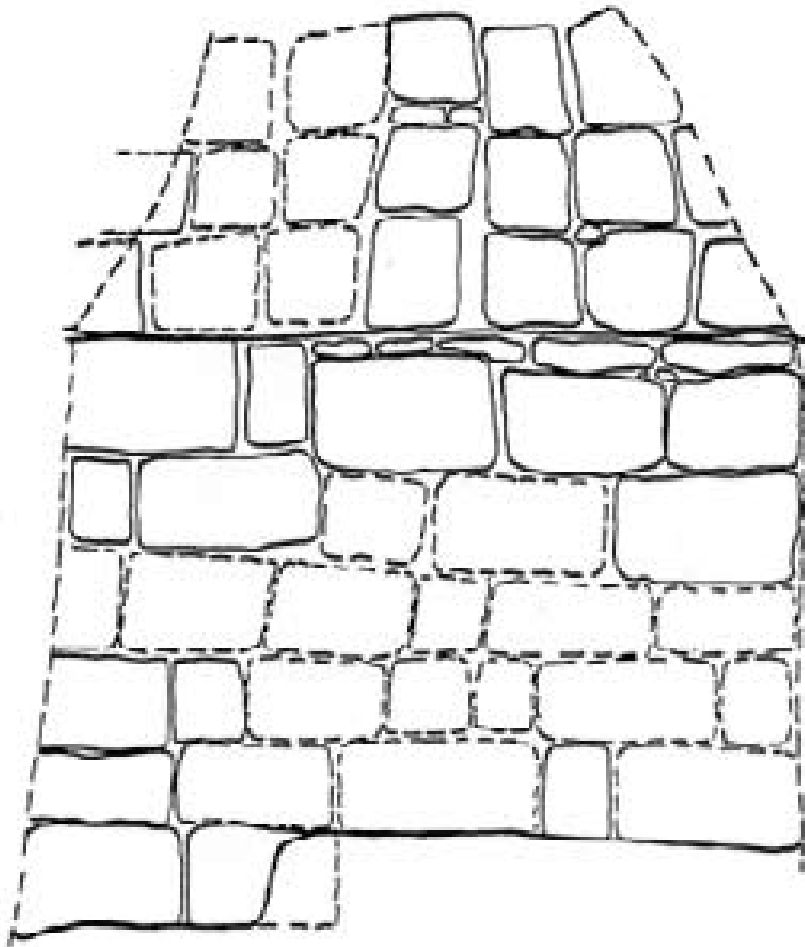

FIGURE 12 EAST SIDE, DETAIL ELEVATION OF MASONRY SCALE 1:20



Photo 14 West side of Bu. 196 before excavation.

0 1m.

→ N

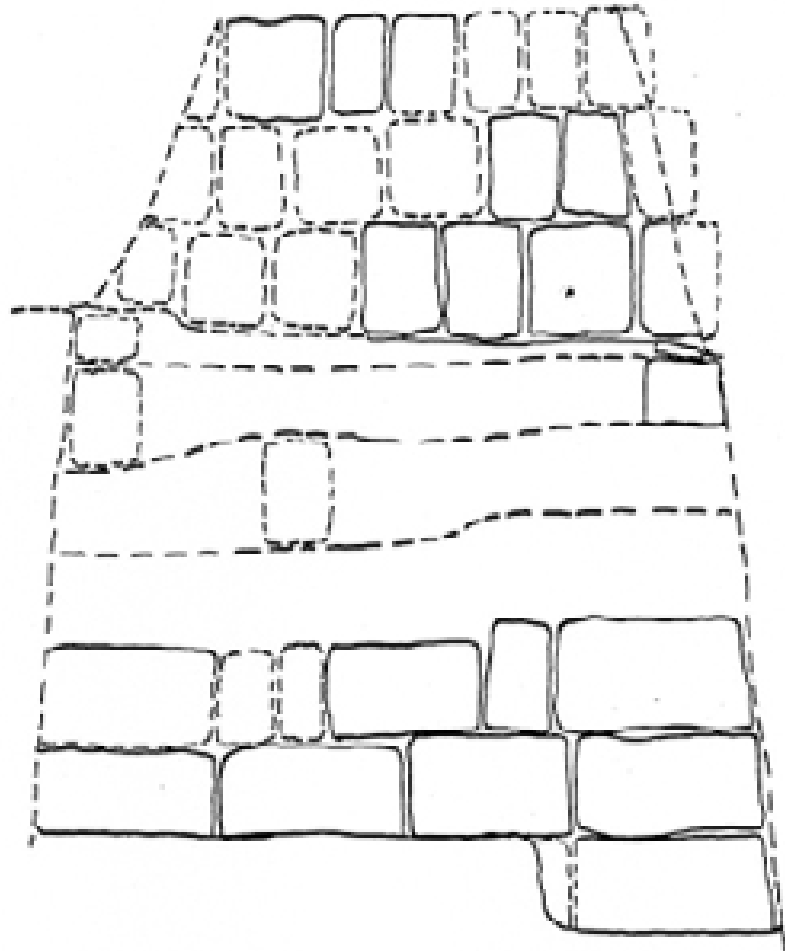

Fig. 13 Bu. 196, west side masonry detail elevation.

There were two holes for wooden cross beams as in the north wall (see p. 35).

EAST WALL

The east wall was the best preserved of all (Fig. 12, Photo 12). The top course was still intact although slightly cracked. Most of the 5th and 6th courses had slumped out of place but were still standing. Here, on the east wall, is the mark made when the wall buckled and was forced against the sub-vault tie beam (Photos 12, 18), and a piece of charcoal. The 1 1/2 by 1/4 cm. got plastered into the wall's surface.

The author remembers that this wall was built after the bench fill, but before the front facing of the bench and the tomb floor plaster. Thus, in the masonry detail elevation there are no whole stones hidden by the bench.

WEST WALL

For dimensions of this wall see p. 30. The uppermost four courses of the wall had fallen. (Fig. 13, Photo 13).

Masonry

The masonry of these walls was similar to that of a typical Tikal Late Classic palace interior (i.e., Str.5D-38-1st). The stones used were rectangular blocks whose sides were roughly finished. The fronts of the stones were covered with plaster and were not observed. For the top course, the

top front edge may have been slightly rounded off; or, the roundness could be mainly a result of the curvature of the plaster. The top of the upper courses was not an even plane, but had numerous bumps and dips. This was noticeable because it was easy to remove the vault stones leaving the top of the wall plaster intact--complete with its wall-top textile impressions (see p. 45), (Photo 19). The unevenness of the wall top was most clearly visible on the west wall; it may, however, be somewhat due to pressure from the vault above.

The wall stones were laid in courses with approximately six main courses and one "leveling off" top course. The coursing was far from exact, with numerous irregularities. This type of "leveling off" course seems to have been a common Late Classic architectural trait at Tikal. The top course of Str.5D-38-1st's walls had an identical course whose especially small size can possibly be explained by two factors. One possibility is that this was the easiest way to get an exactly or approximately level top for the wall's facing masonry; it is easier to cut and fit small stones than to try to get an even top surface out of regular larger-sized stones. It appears that, although the wall stones were generally the same size, there was enough differentiation to create the disruption of courses which is so obvious. There was no noticeable pattern of headers and stretchers. There were always more stretchers than headers.

The alternate reason is that there may have been a pre-

FIG. 14 SEQUENCE OF CONSTRUCTION STAGES, BU.196

A THE GREAT PLAZA AS IT IS PRESUMED TO HAVE BEEN PRIOR TO THE CONSTRUCTION OF THE TOMB. (Plaza surface floor at extreme upper plane, fill reconstructed)

B CONSTRUCTION STAGE 10: RECTANGULAR CUT MADE INTO PLAZA FILL FOR TOMB (sides of tomb cut reconstructed from available evidence).

C CONSTRUCTION STAGE 9: PLACING IN OF THE BENCH FILL (fill may have gone all the way to the south edge of tomb cut)

D CONSTRUCTION STAGE 8: ERECTION OF THE TOMB WALLS (fill behind walls is reconstructed)

E CONSTRUCTION STAGE 7: TOMB WALLS AND WALL-TOP PLASTERED

F CONSTRUCTION STAGE 6: FRONT FINISH MASONRY PUT ON BENCH

 CONSTRUCTION STAGE 5: TOMB FLOOR AND BENCH PLASTERED

G CONSTRUCTION STAGE 4: BODY (IN BUNDLE) AND OFFERINGS PLACED IN TOMB

H CONSTRUCTION STAGE 3: CLOTH(S) HUNG OVER BURIAL AT WALL TOP LEVEL

I CONSTRUCTION STAGE 2: VAULT ERECTED (fill reconstructed)

J WOODEN POLE ROOF AND FLINT & OBSIDIAN BEARING FILL

Drawings are at a scale of 1:20, north to the left and were reconstructed from all available evidence.

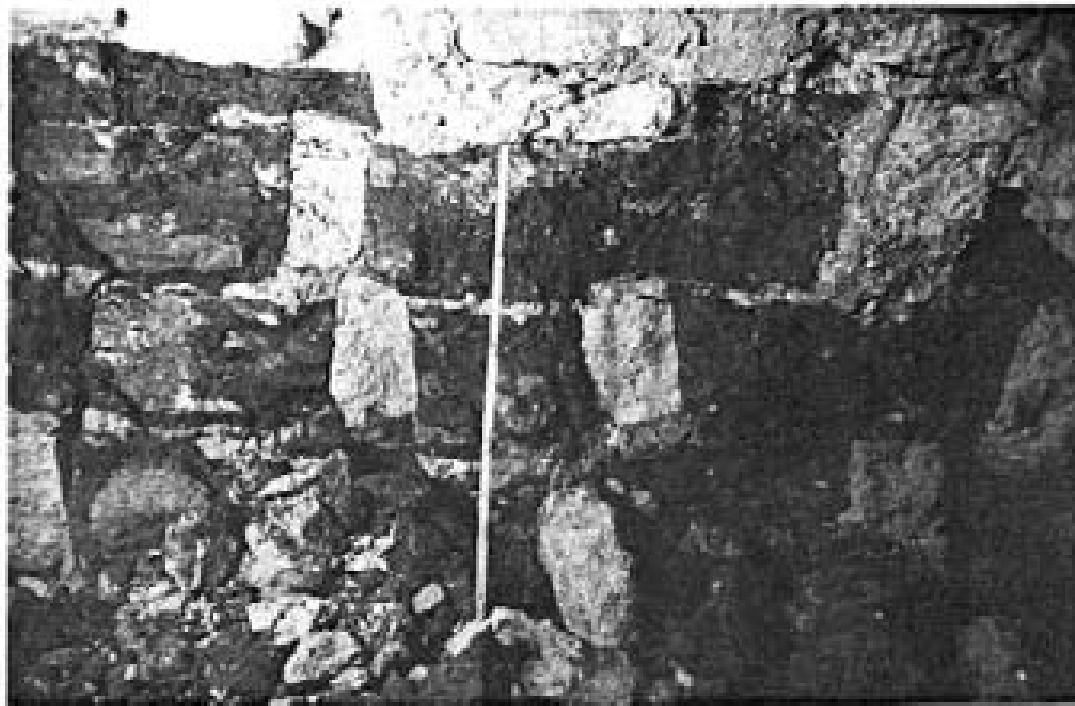

Photo 15 Du. 196, upper courses of north wall with stretcher stones collapsed but butts of headers visible.

determined wall-height governed by a system of proportion. The approximately 30 cm. high wall course may not have come out even under this system.

The mortar used between the headers and stretchers was grey lime mortar; but the ends of the headers were held in place by mud mortar which came right up to the back of the stretchers. Each course was laid as an entity, an entire course being laid before the next one was started. It was, however, not determined whether one course was continuous around all four walls as was the practice in Str.5D-38-1st.

Each course was topped by a layer of light grey lime mortar (Photo 15). This mortar went back at least to the end of the headers, i.e., it covered the mud mortar which was behind the stretchers and around the butts of the headers. It would have been interesting to see how far back the course top mortar layer went. It clearly went back the length of a header. The detailed sequence of construction may have been: after the headers and stretchers of a course were put in place, one workman would put good quality lime mortar around the stretchers and around the front half of the headers. This may clearly be seen in photographs (Photo 15), where there are strata of lime mortar visible over the mud mortar. Whether or not the layer went back all the way to the edge of the tomb cut is not known. The only area where the tomb wall was cut through the plaster layer did not extend far enough back to be recorded; however, in the cramped tunnel such a

fine layer might have been overlooked.

A few sample dimensions for the stones are listed below.

STONE DIMENSIONS: STRETCHERS	<u>LENGTH</u>	<u>HEIGHT</u>	<u>DEPTH IN WALL</u>
	53	32	?
	55	30	21
	55	30	19
	56	30	?
	54	34	?

There was no way to find out how deeply the headers penetrated into the fill, because the walls were ready to collapse completely, and it would have been unsafe to dig out the butt ends of any of the wall stones.

All of the walls had a considerable negative batter which was not entirely a result of partial collapse.

The author is not qualified to speculate as to what forces or faults caused the collapse of the walls but not the vaults, and especially the shearing-off of the fronts of the vault stones without their complete collapse. There must have been great pressures on the walls from fill behind them.

Wall Cross-beams

In both the upper corners of the north and south walls, there were wooden poles spanning the width of the tomb. These poles were inserted during construction, and their presence has immeasurable importance for several reasons. First, the beams show that the north and south walls were built at the same time. Since the south wall was built on

bench fill and not on the floor on which rested the north wall, this demonstrates that the bench fill was the first constructional operation of the tomb.

Secondly, the position of the tie beams fortunately provides proof that the tomb walls, and possibly the vault, collapsed very soon after the burial was sealed.

BEAM MEASUREMENTS

	DIAMETER**	NORTH/SOUTH		TOTAL	
		WALL PENETRATION	SPAN	LENGTH	
WEST, WALL	9 cm.	45/45 cm.	1.98 m.	2.88 m.	
EAST, WALL	11	45/70	2.09	3.23	
EAST, VAULT	11	57/57	ca. 1.70*	ca. 2.84	
MIDDLE, VAULT	14	57/55	1.50	2.62	
WEST, VAULT	10	87/67	1.69	3.23	

** Logwood has an irregular outline and diameters are averages.

* Vault face has been sheared off and the vault has buckled making exact measurement difficult.

These measurements are included here to emphasize how substantial these beams are; they are clearly logwood, an extremely hard, long-lasting wood characterized by an irregular outline in cross-section. The tree still grows in "bajos" or seasonal swamps around Tikal.

When the tomb was found, none of the tie beams or roof beams were still in place. They had all rotted and fallen; but many had fallen and then rotted, the sequence being very important. In the socket holes the fluffy, shriveled wood remains were often present, still maintaining their charac-



Photo 16 East (?) end of tomb before excavation showing fallen wooden wall beams.



Photo 17 Looking west at the southeast corner of the tomb walls, showing fallen wall beams.

teristic outline. In other cases, the socket holes in the walls and vaults were just partially filled with the rotted wood powder. A number of large samples were taken for C₁₄ tests; but no tests were run by the University Museum. A large majority of the beams, both roof, wall, and vault, lay on top of the uppermost debris of the collapsed walls. Of these, most seem to have fallen when not altogether rotten. They lay in recognizable strips and sections (Photos 16, 17). Other wood remains were only slightly buried by collapsed masonry and fill.

The remains of the west wall cross beam lay on top of fallen wall debris. Since the extreme east and west ends of the tomb floor area are protected from falling roof beams by 40 cm. of vault overhang, it is doubtful that a roof beam would end up in this position. In addition, a roof beam would tend to be at least slightly covered by flints, obsidians and other debris from the roof. The fact that this beam, no matter where it came from, lay on top of all the collapsed debris indicates that by the time it was rotten enough to either fall of its own weight or break through pressure, the tomb had already collapsed almost to its maximum extent. Many of the lower courses of the west vault had collapsed as had most of the upper wall courses. The falling wall would hit the wall beam (as indeed there is positive evidence elsewhere, see p. 38) as they fell. If this occurred many years or centuries after the tomb's erection then the beams would be somewhat

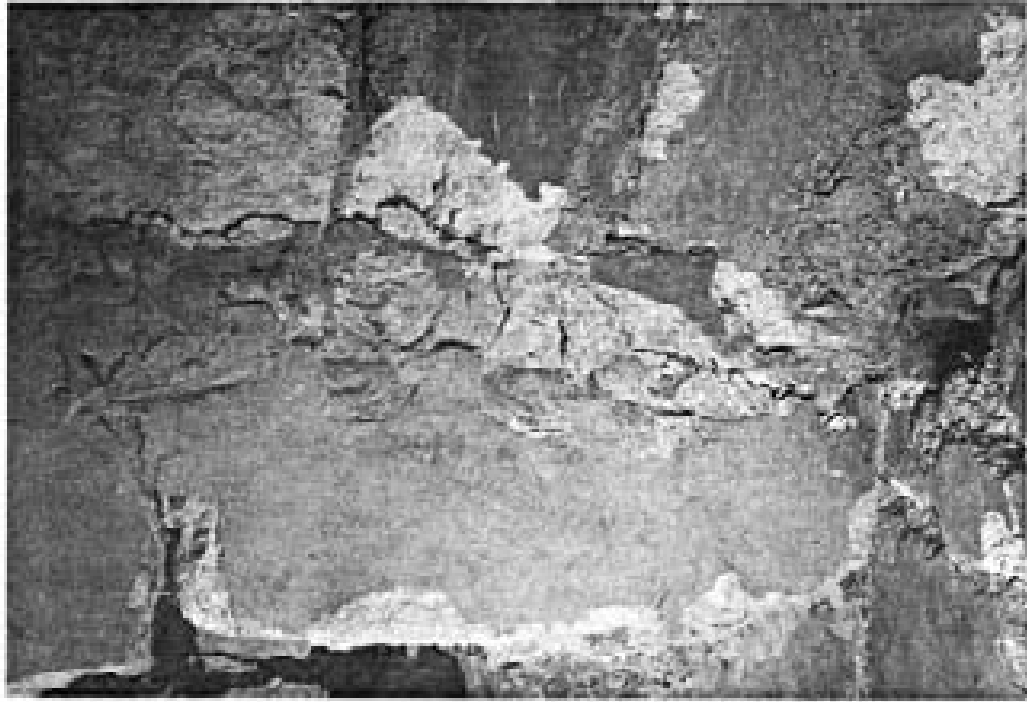

Photo 18 East wall of Bu. 196 showing dent in buckled wall caused by east wall beam.

weakened and would probably break and be mixed in with the fallen debris; but, the wall beam was strong enough not to be disturbed; and, after the large number of years rotting, it finally collapsed of its own weight and fell to cover the already fallen wall debris.

On the east side, there is even more graphic and convincing evidence that the tomb fell in while the wood was still strong. The entire east wall, similar to many other parts of the tomb facing, buckled as a result of the pressure of the tons of fill over and behind it. This pushed, the wall right into the eastern wall cross beam with enough pressure to leave a considerable beam impression in the upper courses. (Photo 18, Fig. 12). Fortunately, the beam was strong enough to resist this thrust; and the wall, slightly pushed out, still stands today.

Other indications that the tomb wall collapsed within at least a few years after its construction were found among the offerings. When a large fallen stretcher stone was lifted up, on its undersurface (it lay horizontally) was the perfect impression of the rim of a stuccoed wooden bowl. Beneath the stone were the remains of the bowl, now completely rotted. Although a wood beam might remain strong for some time, this wooden bowl would probably be weak enough to be crushed after a few decades (???) . For further discussion of this bowl see p. .

A third important result of the presence of the beams

is the fact that the wall-top textile which covered the tomb draped itself over the east beam. When the vault plaster was slopped on, (see p. 46) some of this plaster was caught in the east corners. The cloth eventually rotted; but its impression is recorded on the underside of the overhanging plaster.

Rather than secondarily carve a wall stone to accommodate the beam, the course was disrupted and smaller stones were put around the pole. In the vaults the regular stones were adapted probably because the facing stones had to be a certain size and shape to fit into the preconceived pattern, whereas in the walls there were not so many structural considerations.

At one point the author wondered why there were only two wall beams while there are three vault beams. A middle wall level beam would have made it difficult if not impossible to lower in the body of the deceased, whereas the middle vault beam would have come in handy to support scaffolding or planking on which Mayan workmen could sprawl to build up the vault. Between the vault beams the maximum space is 1.30 m. If the body was not placed in until after the vault was erected the priests would have a hard time getting the body in. The body would have to have been tilted, which would have caused all his jade to bounce around; however, as found, all his ornaments were in perfect natural position. That the body was "dressed" inside the tomb is possible but doubtful.

Artifacts From Fill Behind the Walls

All the cultural material which was incorporated within the fill behind the walls was mixed with that of the collapsed roof material in the tomb chamber and could not be separated. So, most of the sherds, etc. which occurred in the debris over the tomb offerings were from the wall, except for the flints and obsidians. There were no offerings of flint and obsidian chips behind the walls or vaults as there were over the roof.

CONSTRUCTION STAGE 7: PLASTERING OF THE TOMB WALLS

The next constructional activity was that of completely plastering the wall faces and "wall-top burial-pit ledge" with a coat of lime plaster of maximum thickness, 1 cm. The plaster was generally smooth and light grey. It had not, however, been smoothed as much as some wall plasters. It appeared that the plaster was either smoothed or somehow finished with a brush. It is possible that the visible brush (?) strokes are only on a final coat which lies over a rough main layer; but this is only a guess, as laminations of the plaster were not observed or looked for. The plaster was applied in 30 cm. semicircular strokes. Whatever tool was used had an effective dimension of 8 cm. According to field notes, the plaster application was neat but not flawlessly smooth (see Photo 18). No hands were used directly to apply the wall plaster; of importance because the vault "plaster"

was carelessly slopped on by hand and hand and finger marks are evident everywhere (see p. 52).

The wall plaster did not stop at the upper edge of the wall but made a right-angled turn and covered the horizontal plane of the top of the top course and the fill behind the wall all the way to the edge of the tomb cut. Upon entering it was evident that the wall plaster made a neatly rounded 90° turn to cover the top of the uppermost wall course. However, in removing the vault stones to enlarge the working entrance to the tomb (for overweight visitors), it was discovered that the wall top plaster continued horizontally and that on the upper surface of the plaster was the well-preserved impression of a textile. A trench was immediately carefully dug eastward, following the level of the top of the wall 1.60 m., until the plaster layer gave out against the vertical edge of the east side of the tomb cut (Fig. 9). In delicate excavations such as this, the Guatemalan workmen showed what careful, patient, and skilled excavators they could be. All the vault mass was removed and the cloth impression in the fragile plaster layer was left perfectly intact and clearly visible. Later this trench was dug down to the level of the base floor (Fig. 9) to follow the tomb cut down to its bottom limit. Later, the textile impression was found to occur over the wall top on all sides of the tomb. In many places the top wall courses had fallen, but the bottom courses of the vault remained in place. In

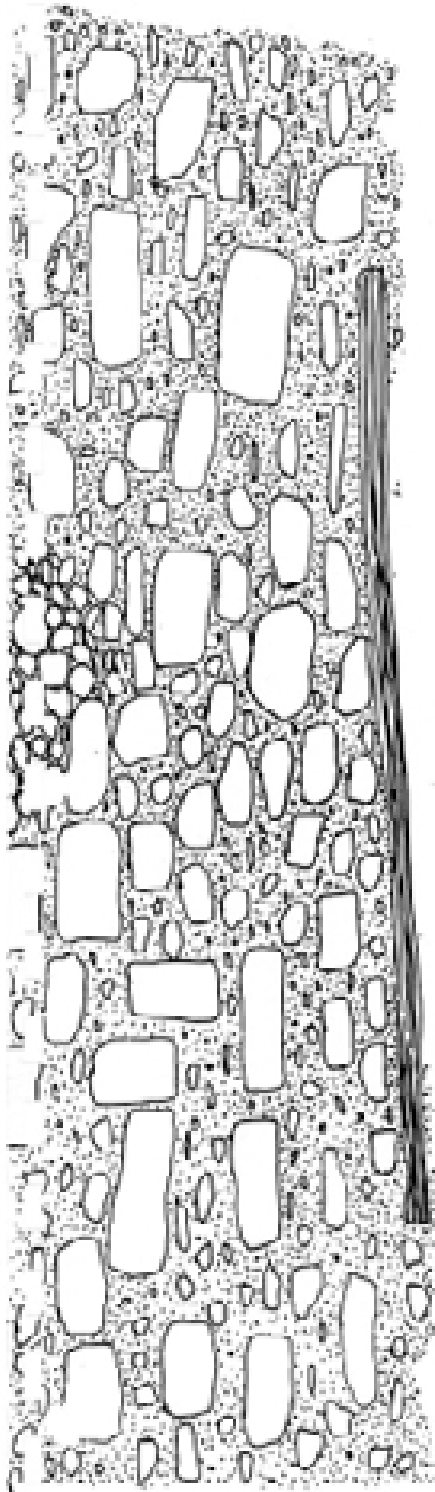

Transparency # 1

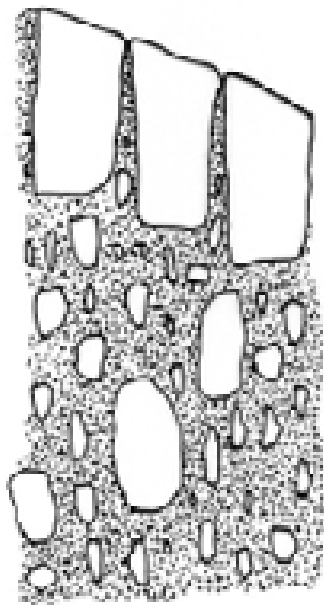
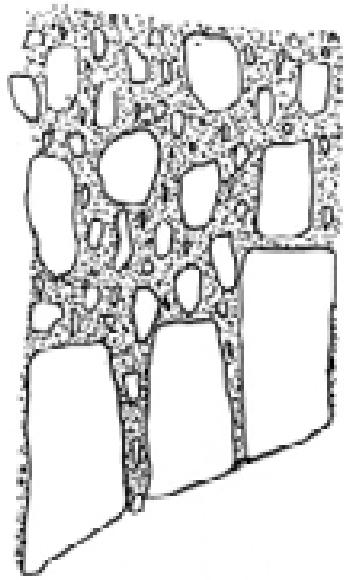

Transparency # 2



Transparency # 3



Transparency # 4



Transparency # 5

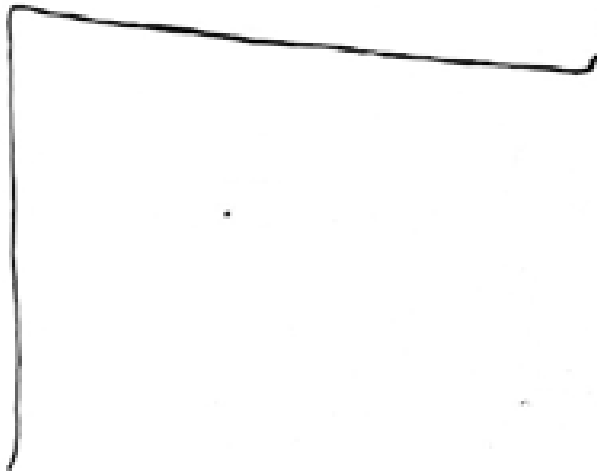

Transparency # 6

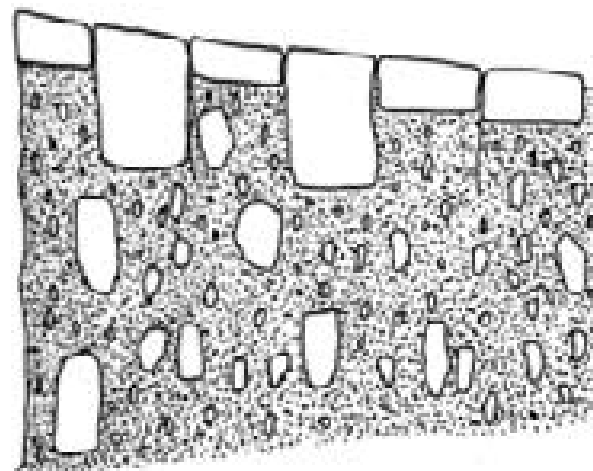
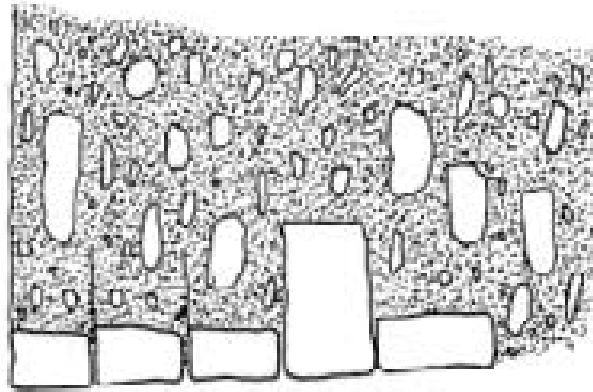

Transparency # 7

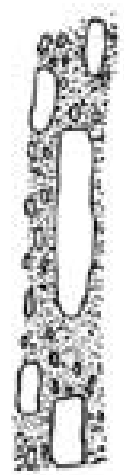

Transparency # 8

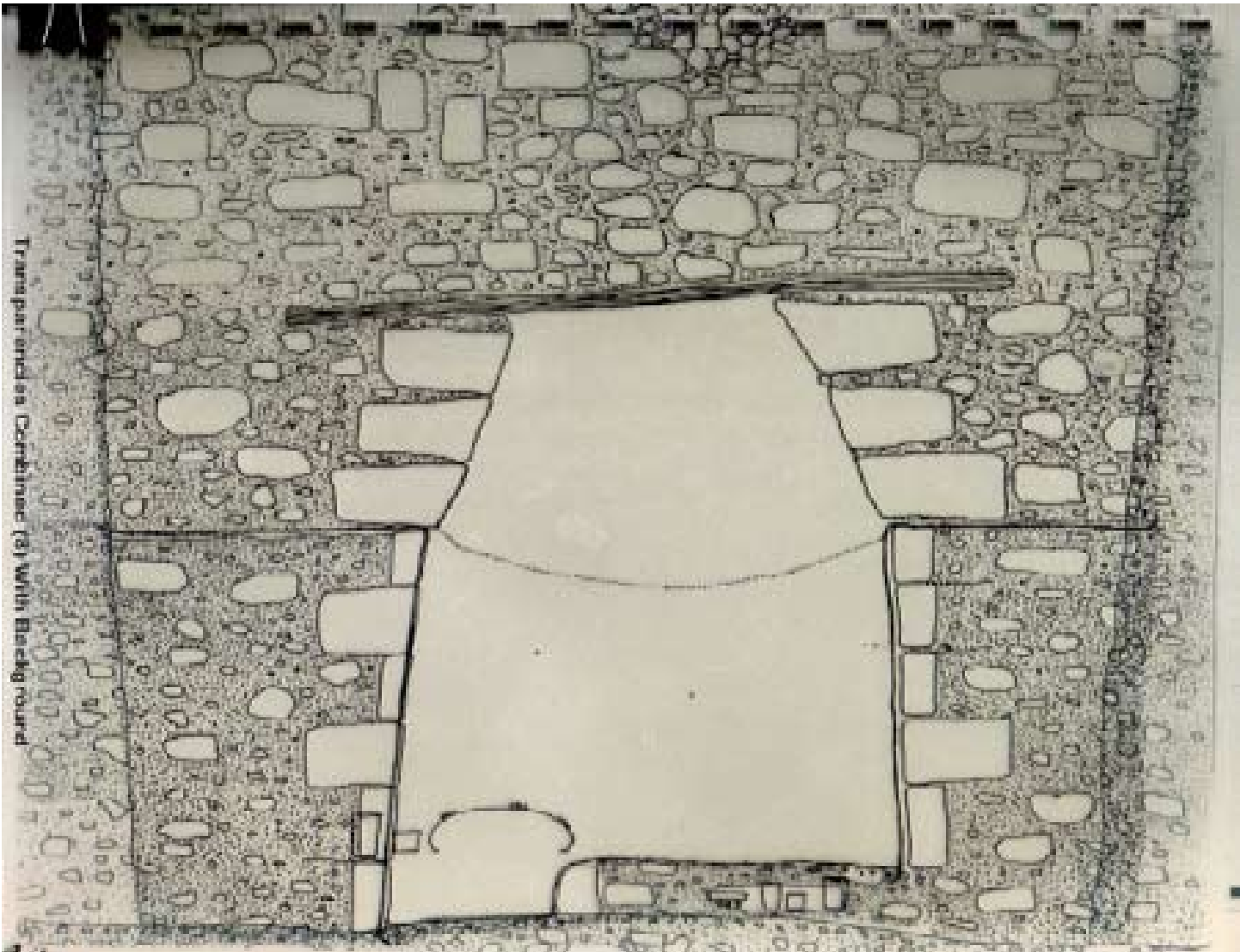

Transparent endosperm Combined (8) With Barley round

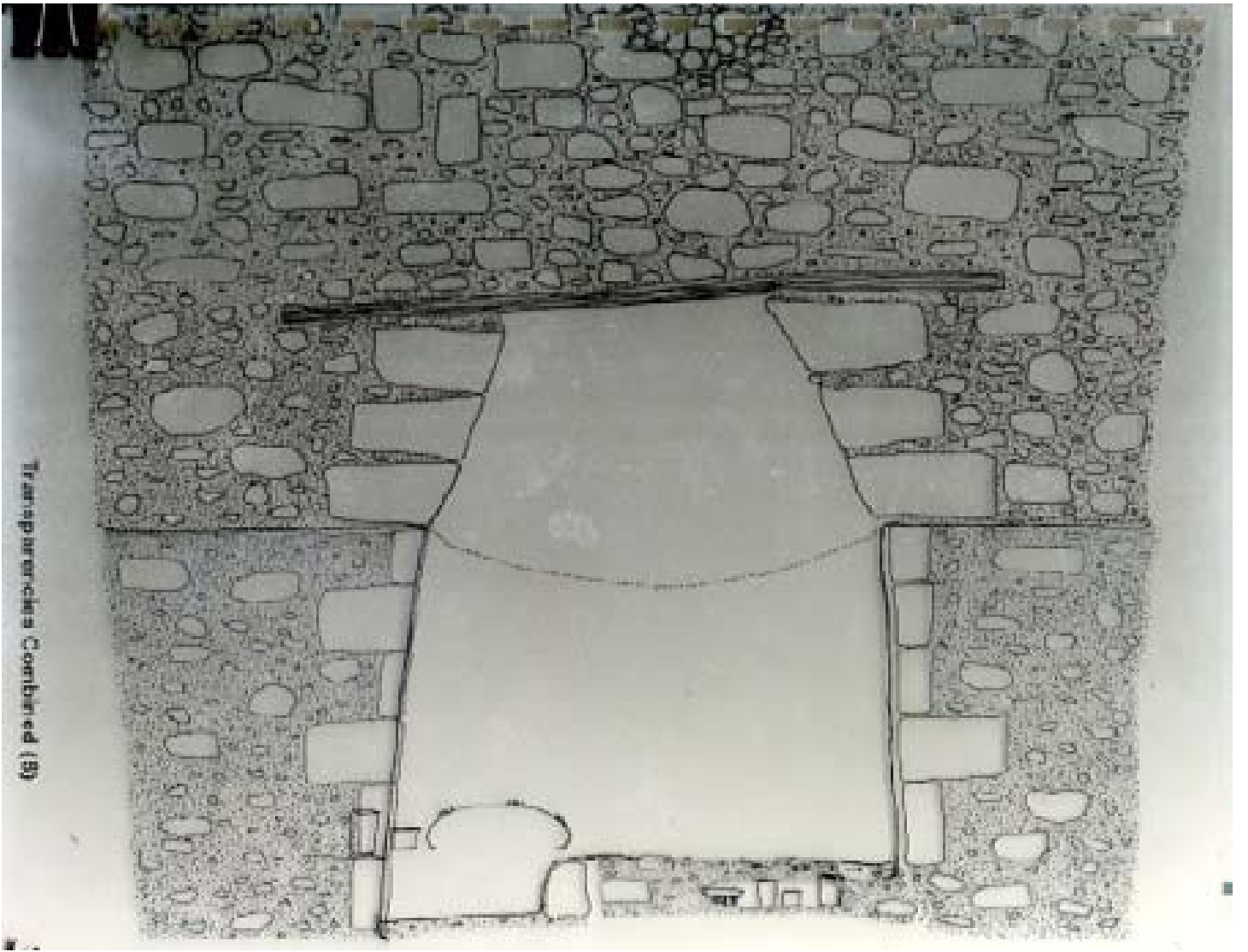

Tran-sper-en-ches Com-bred (9)

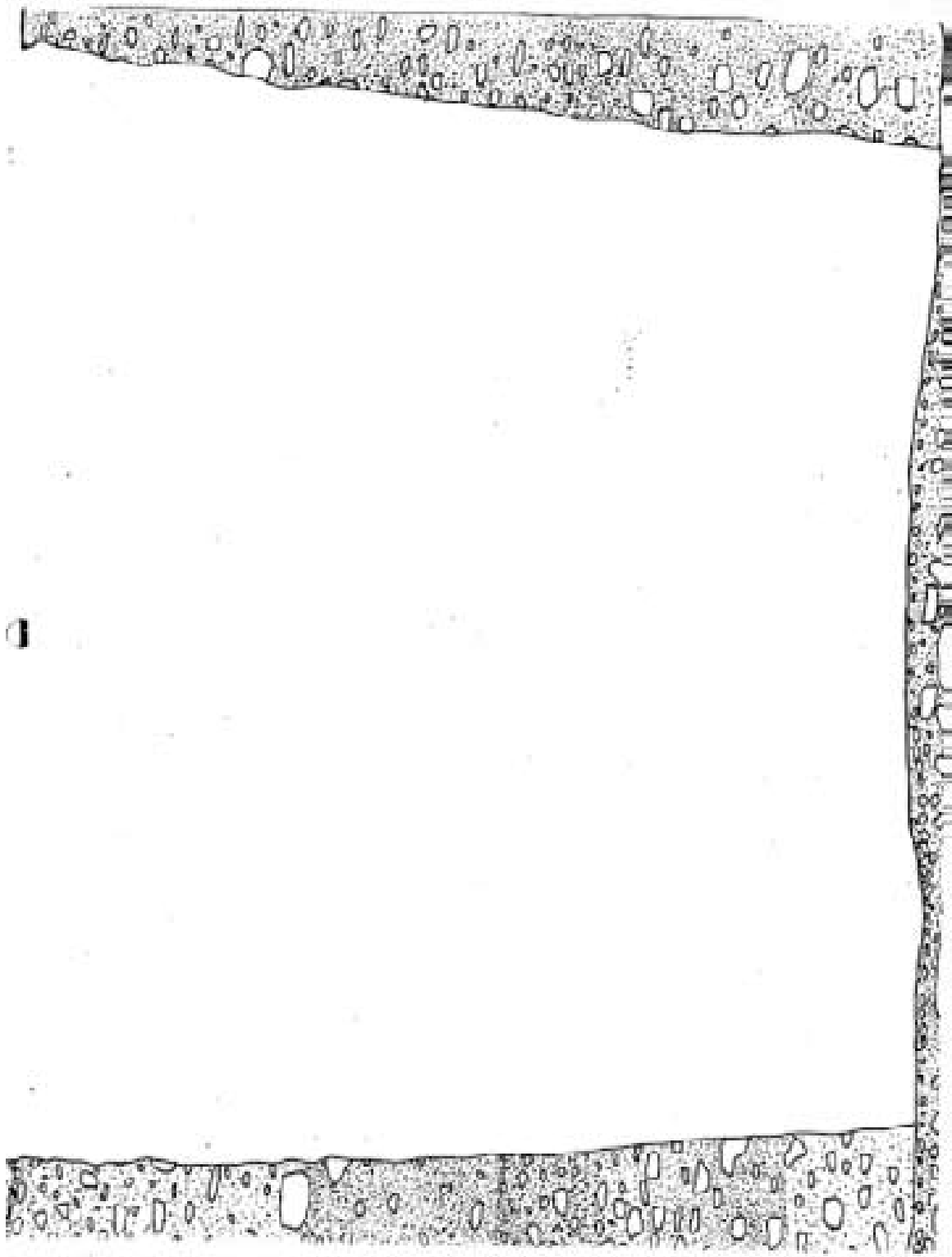

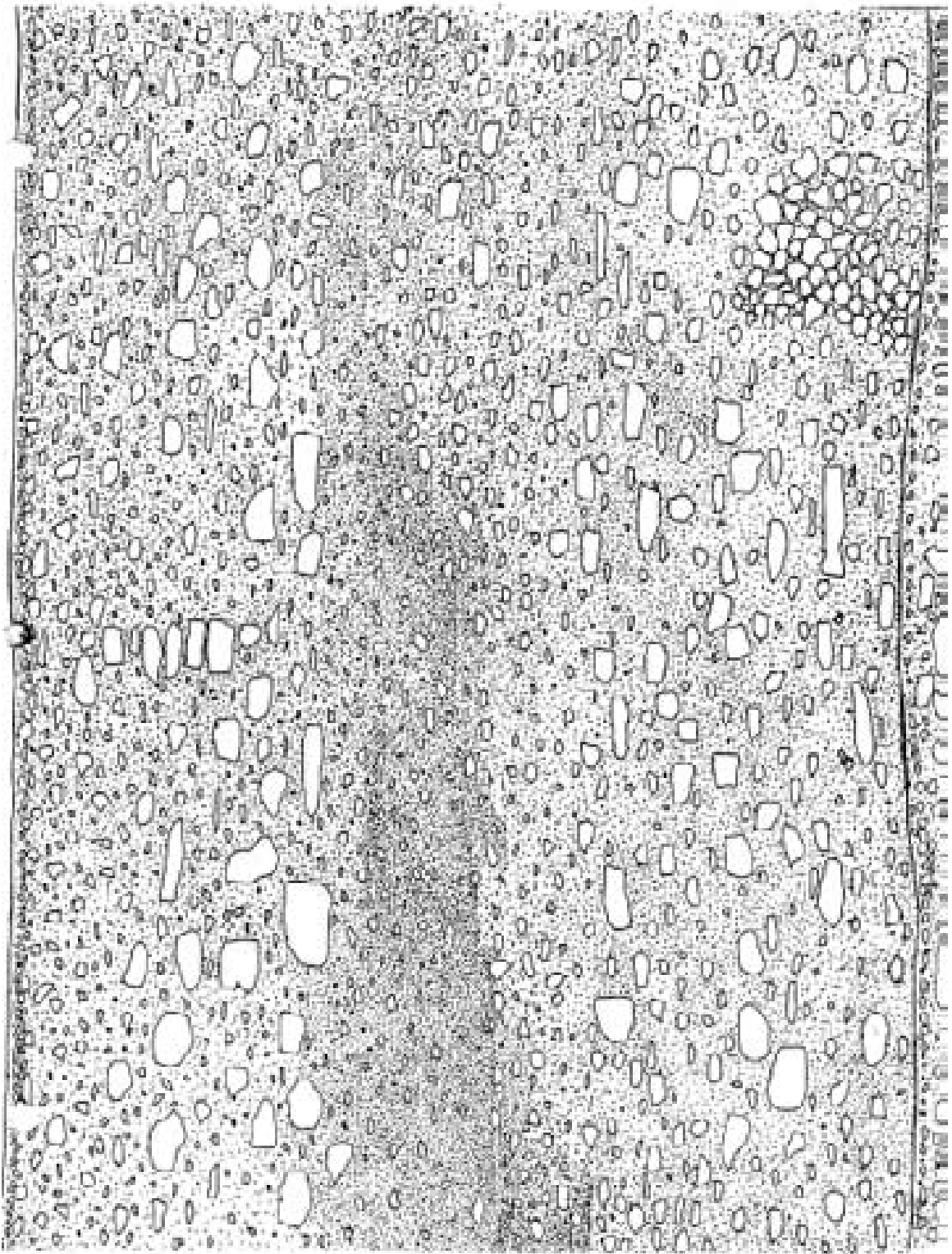

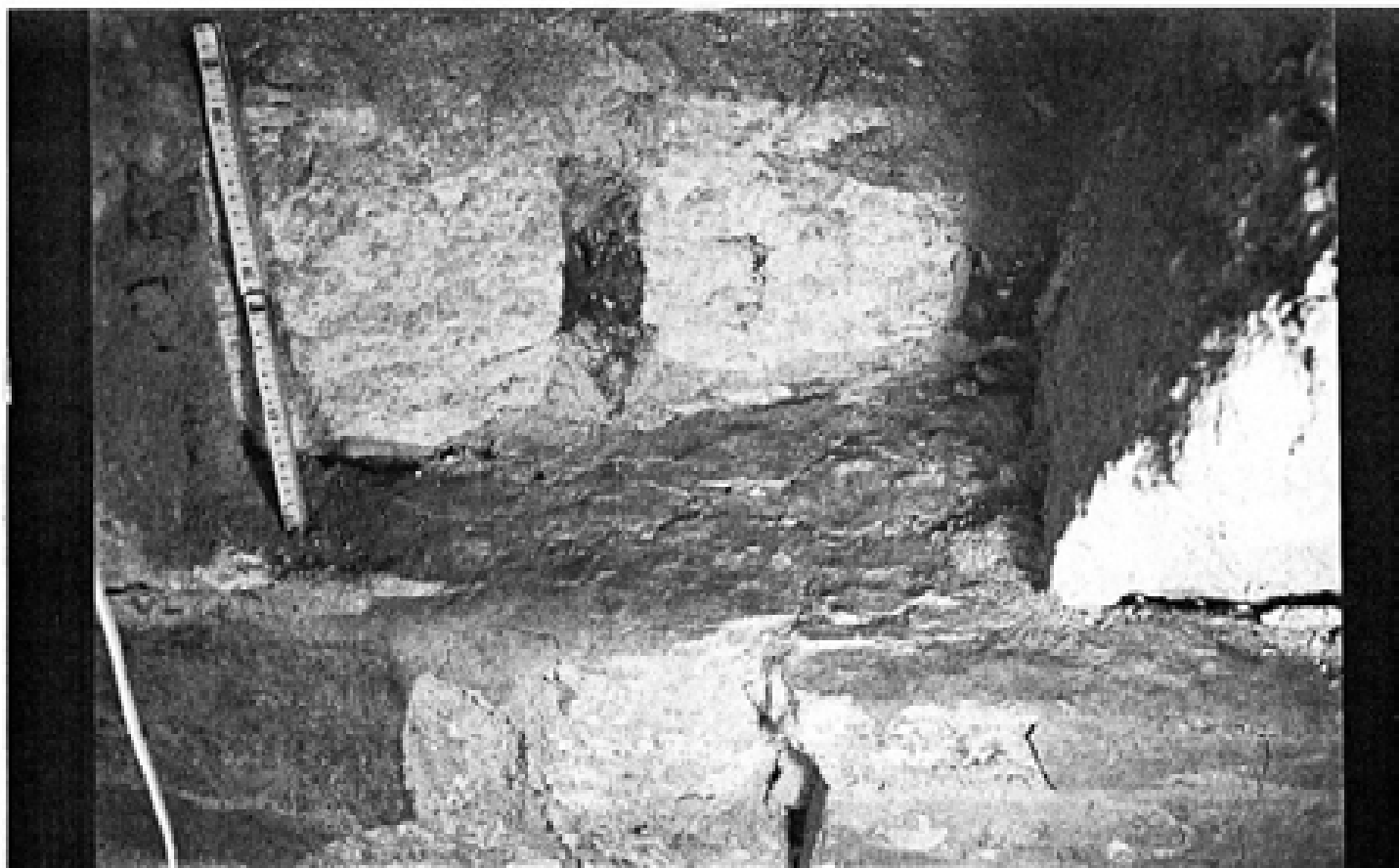

Photo 19 East wall of Du. 196, wall top plaster turn-over with the vault stones removed.

such places the textile impression was visible in the mortar under the vault courses (see p. 45).

CONSTRUCTION STAGE 6: FACING PUT ON BENCH FRONT

Next, a row of facing masonry was placed on the north side of the bench fill. The stones were the same type as those used on the walls. It was not observed whether headers, as well as stretchers, were used. The stones were all laid on edge and were an average of 30 cm. high.

CONSTRUCTION STAGE 5: PLASTERING OF TOMB FLOOR AND BENCH TOP

The following step was to cover the floor and bench top with a layer of plaster. It is difficult to determine the original smoothness of this application, because the great weight of the collapsed walls and vault caused dents to be made in its surface. There was no imprint of a woven mat on the bench top such as was so clear on the Bu.116 (Temple I) bench. The floor was not as smooth as the floor in an average building room. It dipped down as it went under some of the walls; part of this effect may have been caused by the weight of the walls.

No shards were uncovered from underneath the floor.

CONSTRUCTION STAGE 4: INTERMENT

At this point the deceased Maya was placed in the tomb

along with all the offerings. Reviewing the evidence in the tomb, both Chris Jones and Dr. Wm. Coe thought that this sequence: tomb pit - tomb walls - burial - cloth - tomb vault, was possible; but George Guillemin disagreed. To the excavator this was not a preconceived idea; bit by bit, as he excavated and took notes, it appeared that this is what occurred because of the evidence uncovered. Such a sequence of events depends somewhat on the great difference in construction technique between the building of the vault (hastily and sloppily built and unplastered) and the wall (carefully built and plastered). The evidence that led the excavator to establish the hypothesis that the burial was made before the vault was raised is discussed in greater detail on p. 45.

All information relating to the actual burial, sequence of placing in the offerings, the description of the offerings, etc. is on p. .

That the Mayans went to all the effort required to create an area surrounding the tomb (the area covered by the wall- top turn-over plaster) indicates that there was something which made this action desirable. After the erection of the walls and their plastering there was a 1.40 m. wide flat ledge around the whole tomb chamber 2.20 m. down from the level of the plaza (Fig. 14). It would have been a simple matter to lower the body, probably by means of a rough stairway, to the ledge and then into the tomb. The textile was then stretched over the burial to keep mortar from falling on the body while

the vault was being built. The usual reconstruction of the burial ceremonies has priests and workmen sweating as they lower or haul the litter and offerings down a narrow passageway or through a restricted hole in the vault or through the area where the capstones were later placed. However, in some cases it would have been physically impossible to get the body in through the vault.

In Temple I's Bu.116 a considerable extent of the aisle was completely free of offerings; thus, its excavator postulates that the area was used as "foot room . . . from this area . . . they made their exit through an opening in the vault by means of a ladder . . ." (Trik, 1963, p. 10). The author, unfortunately, was not able to get into Bu.116 because it had been backfilled. From photographs it appears that it would have been extremely difficult to enter the tomb through the top of the vault because of its narrowness; indeed, its excavator himself had to enlarge this space to allow for his own entrance: "After removal of the capstone the opening was enlarged to allow entrance to the chamber" (Ibid., p. 8). From the only photographs the author had available, the vault masonry of Bu.116 looks just like that of Bu.196 in that no overall plaster coat was applied. The walls of Bu.116 had almost completely collapsed, but the stubs looked identical to the Bu.196 walls in that they were covered by a layer of plaster. Might there have been an undetected cloth at wall top level?

CONSTRUCTION STAGE 3: CLOTH STRETCHED ACROSS BURIAL AT WALL
TOP LEVEL

After the burial was installed and definitely before the vault was raised, a textile or textiles were laid starting from the edges of the tomb cut and then stretching across the tomb (the author's opinion) or going to the top of the vault (George Guillemin's opinion).

That there was a cloth on all four sides of the tomb at wall top level is undisputed. The imprints of the cloth were visible on top of all four walls. That the cloth went all the way to the edge of the tomb cut was clear from excavations on the east side of the tomb. Here, the vault mass was removed and the clear imprints of the textile went back to the east edge of the tomb cut. It is presumed that the same thing happened on the other three sides.

That the cloth extended out from the walls and was meant to cover something is also uncontested. In three places it was clear that the cloth came out (horizontally) more than five centimeters. It either went up or it went down, or was stretched across the tomb.

It definitely did not just hang down and cover the walls, because there are plaster impressions showing that it draped itself over the east sub-vault tie-beam.

The evidence for the stretching of the cloth(s) over the burial was found in three well-preserved locations. First, in both the east corners the east sub-vault tie-beam



Photo 20 Sta. 104, northeast corner showing gaps of vault mortar caught by cloth dumped over east wall from east bank.



Photo 21 Sta. 105, southeast corner showing gaps of vault mortar caught by cloth draped over east wall from east bank.

was within a centimeter of the wall, parallel to the east wall (Photos 20, 21). The cloth overlapped the beam. Then, when the vault was being hastily constructed great gobs of mortar dripped down the vault facing and caught in the cloth; in both corners, handfuls of mortar were pressed into the corner to cover the interstice between the top of the wall and the bottom of the bottom course of the vault. Thus, there is a chunk of mortar projecting about 4 cm. from the wall. On its underside is the impression of the textile. In this spot there is, however, no proof that the cloth went any further than over the east tie-beam.

On the west half of the south wall, there was one place where the uppermost course of the wall masonry was preserved. Here, also, gobs of plaster had been caught by the cloth in such a way as to indicate that the cloth had been extended outward and been held at its other end (Photo 22). At the time when the tomb was excavated, the author had no close-up equipment with which to photograph this section. The few days his personal camera was in the tomb was enough for mold to grow between the lens elements. No 1:1 detail section was drawn as should have been. The chunk of extending plaster was so fragile that the mere touch of a tape measure would have been enough to cause its collapse and destruction.

To George Guillemin it seemed that the cloth went up and not across. There are several problems with this interpretation. First, up to what? When the cloth was put in, there

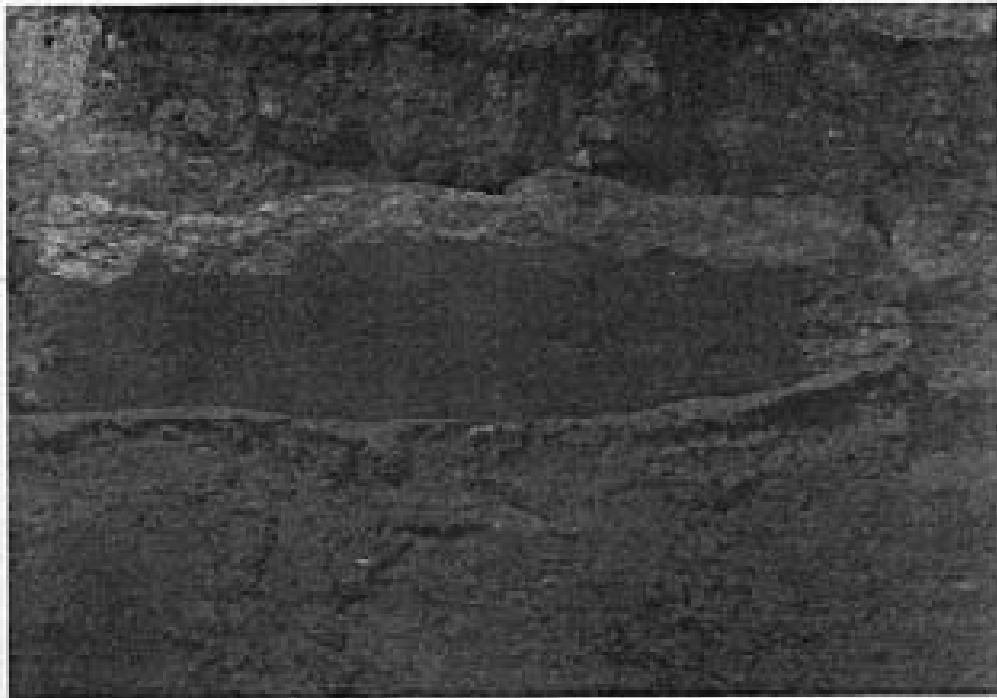

Photo 22 Bu. 196, south wall top showing where vault mortar was caught by the wall-top cover-cloth.

was nothing above it but the blue sky. Secondly, why would the cloth go up? It would have made it awkward to build the vault with a cloth in the way. The author is convinced mainly from existing evidence and also from supposition that there was a purpose in having the cloth stretched across the tomb. The purpose would have been to protect the contents of the burial from dripping mortar as the vault was hastily erected.

According to Ed Shook, in one of the Str.5D-33 burials the body and offerings were obviously placed in before the vault was built. In this burial there was evidence for the vault being hastily built with mortar slapped on by hand. Also, a mat had been spread over the entire tomb and had caught the dripping mortar.

CONSTRUCTION STAGE 2: ERECTION OF THE VAULTS

EAST VAULT

The burial chamber was discovered on Nov. 5th, 1965 when, after over a month of tunneling, the workman's pick went through the second course of the east vault into an extensive void (For more information on the method of finding and excavating the tomb see page). From this hole it was possible to look in and see the tomb. To effect entry a few more vault stones were removed (Photo 19). Later, an east-west trench was cut through the entire east side of the tomb

all the way to the east edge of the tomb cut (Fig. 9). This was the only vault which was cut through. In general, the vaults were much better preserved than the wall faces. All the vault stones of the east vault were still in place. The fronts of three of the stones had somehow been sheared off. The dimensions of this and the other vault faces are given below.

	VAULT OVERHANG	VAULT SOFFIT	VAULT RISE	WIDTH AT TOP	WIDTH AT BASE	NUMBER OF COURSES	ANGLE *
NORTH	36 cm.	2 to 6	90*	3.50 m.	4.20	three	75 - 63°
SOUTH		4 cm.	80-90	3.40 m.	4.18	three	64°
EAST	30 cm.	4 cm.	91*	1.22 m.	2.00 m.	three	69 - 65°
WEST	28 cm.	4 cm.	100 cm.	1.18	1.93	three	72 - 62°

*Difficulty to measure accurately

The base of the vault is approximately even, as it rests directly on top of the cloth over the wall top plaster. It is considerably more level than the base of the west vault and slightly more level than the north and south vault vase surfaces. Half of the top of the vault had to be removed in order to enlarge the entrance to the tomb; but it was uneven and sloped down to the north. There was no vault top pause level or layer of plaster (see p. 58). In section, the profile (Figs. 8; 9) is uneven but approximates a straight line. None of the vault faces produced a regular plane but some of the distortion was produced by pressure and the collapse of the walls below. In other cases the unevenness is

original and is a result of hurried installation. In one place between the first and second courses, there is what at first looked like a round plug, 5 cm. in diameter. This may just be a spall stone thrust out, although there were few, if any, spall stones used in the vault facing. The masonry will be discussed on page 51.

WEST VAULT

All the stones of this vault face are still in place (Photo 13, Fig. 13). Most of the stones on the bottom course have lost their front faces but their butt ends are still in place. Such slight decay was probably a result of the collapse of the top two courses of the wall below. The top of this vault is the most level of all and comes closest to having a vault top pause line. It did not appear, however, that any attempt had been made to put a special course-top-layer (see glossary) of mortar prior to putting the roof poles in place. The numerous cracks in the vault's face testify to the intensity of the pressures it has withstood. For this reason and because the wall below has fallen in, it is difficult to establish precisely how irregular the top of the wall below was. From the course top plaster layer it appears that the wall was not even at its top but was higher on the south side. As with the other vault faces, its profile is not perfectly straight but is a close approximation.

NORTH VAULT

The north side vault facing is well-preserved; only a few of the stones have chipped faces. Almost all the upper courses of the wall below had collapsed. (Photo 25). The top of the vault is messy and uneven. The same mortar which was slopped in between the stones was dribbled over the top, no attempt having been made to provide a smooth flat surface for the roof beams. It was difficult trying to estimate how much of a time interval, if any, there was between the laying of the roof beams and the finishing of the vault.

SOUTH VAULT

About two thirds of the stones in this vault have lost their front faces, especially in the east part of the vault. Of the stones with missing front faces, all have their butt ends still in place. It was impossible to get far enough away from this vault face to take a meaningful photograph; but the preserved parts of the vault are somewhat visible in Photo 22, and the vault butts are visible in Photos 23 and 24. A detailed description of the vault masonry follows on page 51.

The top of the vault is probably the most uneven surface of all, varying in height from 80 cm. to 90 cm., although it rises from an approximately level base surface. There was no attempt to make a level base for the roof poles (see p. 58).

The south vault face was pierced by a row of three beams

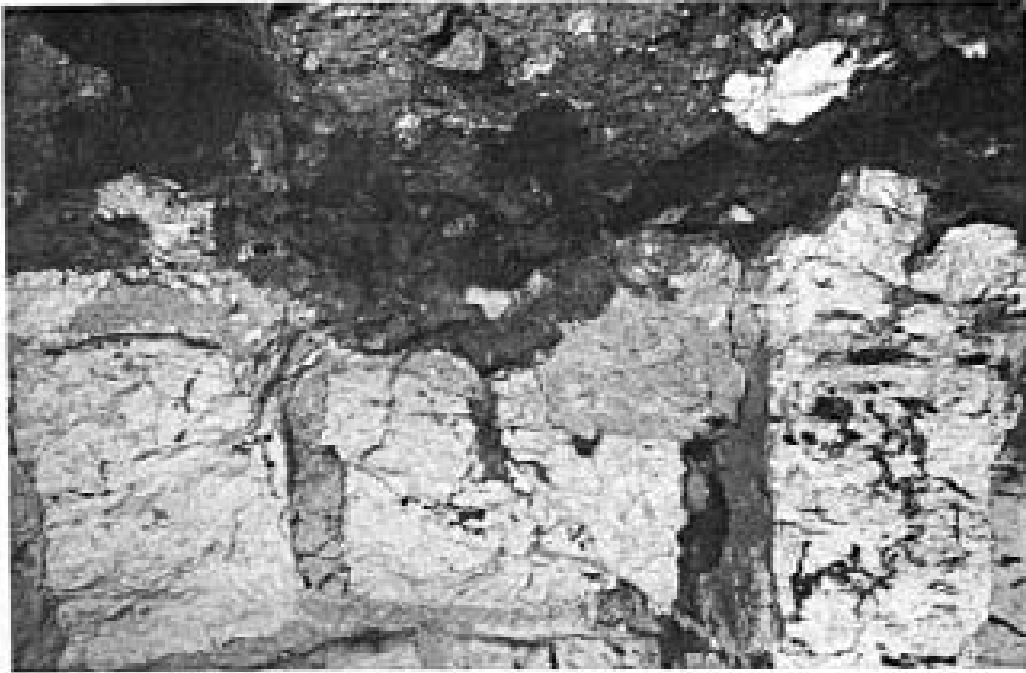

Photo 23 Ru. 196, upper vault courses and ceiling beam holes.

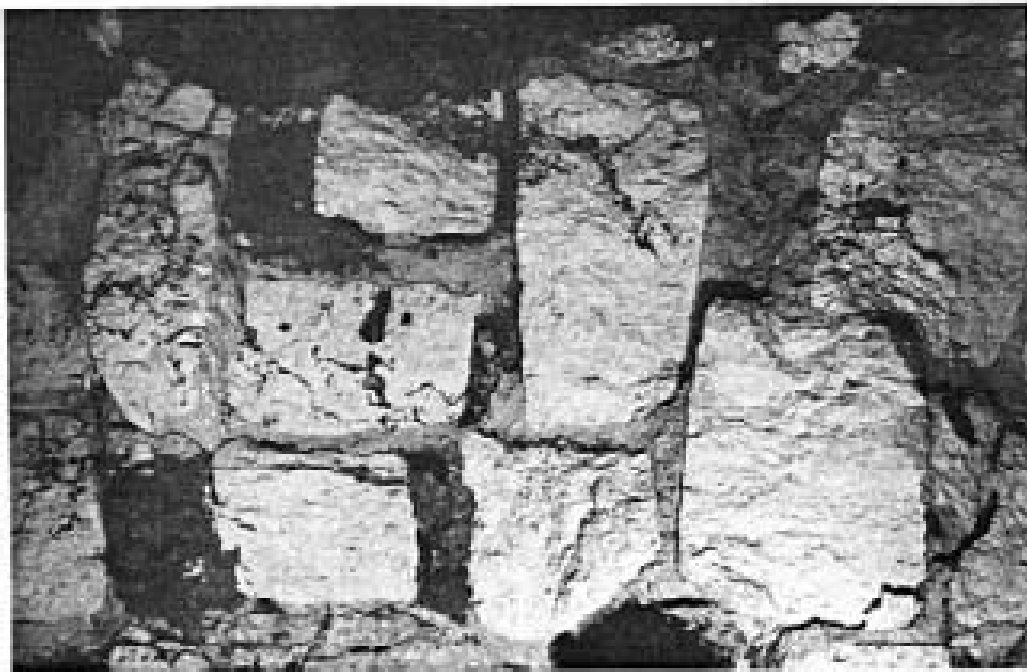

Photo 24 Ru. 196, upper vault courses, south side (9).

(see p. 57). These poles rested over the top of the first course, the middle one lying about 10 cm. lower than the others. For the end beams there was merely a gap in the vault stones. It is possible that, in the actual vault face, some of the empty space thus created was filled in with a special small stone as on the north vault face. For the center tie-beams, all the stones around it were specially modified (partially visible in the lower center of Photo 24).

Masonry

The stones used are standard Tikal Late Classic vault stones. Because all the vault stones were still wholly or partially in place, there was no way to study a single stone to see its exact shape. If any whole stone had been pried out of the wall to be measured, the whole vault might have given way. The fronts of the vault stones were beveled. From the one place that the vault was cut through (Fig. 9), it could be seen that the stones were tapered and that the butts were not cut to perfect squareness. The front surface was finely finished, but the edges and corners were not squared off.

The vault stones were clearly and undeniably pre-plastered (i.e., plastered before installation) with a thin wash coat. This plaster coat was not a result of the stones having been ripped out from some other vault. Many times stones are re-used and retain a plaster coat as a result of

their having been previously located in a plastered wall or vault. If the stones had been ripped out of an earlier plastered vault, then the plaster would have jagged edges on each individual stone as a result of the stones' having been forced away from one another. Also, especially near edges or wherever the front face of the vault stone is rough or nicked, the wash coat makes no attempt to even out the surface. In addition, the plaster would probably be slightly thicker if the stones had been plastered while part of a regular building's vault. The plaster wash may have been applied with a very fine brush; on one stone faint marks, possible brush marks, could be made out.

No plaster was applied over the vault faces as was applied over the wall faces. The same mortar which was used between the stones was smeared very messily by hand in the interstices and over parts of the front of the stone (Photos 25, 26, 17). This mortar was so wet when it was applied that it dripped all over everything, and no attempt was made to clean things up. Although there were drip marks all over the vault face, there were very few drip lines running down the wall, because the cloth caught most of the falling mortar (Photo 22). The mortar seems to have been applied exclusively by hand. Finger marks are visible all over the vault face (Photo 25). Most of the strokes go up and down with a few diagonal but no horizontal imprints. It was difficult to determine whether the marks were made by someone standing in



Photo 25 Bu. 196, finger marks in vault mortar (north vault).

the tomb or someone perched perhaps on scaffolding supported by the vault tie beams. There is a difference between the "trails" left by a hand full of wet mortar moving up and that of a hand moving down. If the vault was being built after the body and offerings were in the tomb, then the workmen would be standing on the wall top ledge leaning over the vault. This would certainly explain why the vault face was nowhere near a perfect plane, whereas the wall did make a good plane. According to the hand "trails," it is plausible to suppose that the hand movement was from above.

Two slightly different kinds of mortar were used: a very runny grey and a slightly brownish-red off-white. Where there was overlap, the grey mortar always overlapped the other. The reddish substance seems to have been the mortar used to hold the stones together, with the grey used to dab into the interstices. There was no paint applied to the vault and no cinnabar; the fact that there was some cinnabar on the walls and a lot on the tomb floor might indicate further that the body was placed in before the vault was built.

Another fascinating feature of the vault construction was that the faces of the vault stones had been intentionally chipped or accidentally battered after pre-plastering and before installation. The proof that this damage happened before installation was the presence of plaster drip lines dribbling down over the chipped portions of the stone (Photos 26, 27). The chipping could have been a quick attempt just before or



Photo 26 Su. 196, drip lines of vault mortar.



Photo 27 Su. 196, drip lines of vault mortar (north side ↑).

during installation to even up the face of the stone. The tool or implement used to inflict the marks had an effective surface about 5 cm. wide. On the south side one stone had its entire coat of pre-plaster chipped off.

Mortar Caught in the Wall Top Cover Cloth

As has been demonstrated previously, there was a cloth or cloths stretching, at wall top height, over the entire tomb. This was in place presumably after the burial had been completed and definitely before the vault was begun. The author presumes that this cloth was put in place just before the vault was built in order to keep the wet vault mortar from dripping all over the body and offerings. That this cloth served its purpose is clear from three major places where plaster in large amounts fell down and/or was stuffed in corners with the cloth keeping it in place. Details of this have been provided previously (see p. 46).

Coursing

Basically, all vault faces were built in three courses. In one place on the south face, two stones were used in one course. In the east and west end vaults the courses were kept level within 4 cm. or so; but this is to be expected, as the courses are not very long; each course is from 28 to 31 cm. high.

In the north and south vault faces, the size and shape

of the vault stones varies considerably within a generalized standard size, causing much disruption in course top levels.

Mortar Layers at Course Top Level

The front of the vault stones were held in with a light-colored lime mortar. The fill behind the vault stones and the rear half of the vault stones was held together by a mud mortar. It appears that lime mortar was precious and was used only where necessary (or visible?); this same system of mortaring was used behind the wall stones. With the vaults it was not possible to see whether every course was topped by a lime mortar layer, because only on the south side was the face of the vault sufficiently collapsed to see the butt ends of the stones. This system is plainly visible in the photograph (24). The fronts of these stones had been somewhat sheared off; and there was dark brown mortar between the majority of the stones in the vertical spaces. In several instances mud mortar was used between the stones to within 5 cm. of the front. The fronts of the stones were cemented with light grey lime mortar. Running over the top surface of the first and second courses could be seen a thin layer, 1 to 2 cm., of white lime mortar going back to where it covered the mud mortar binding the back ends of the stones. The extent to which these mortar layers went back was never adequately checked. Capping a course with a layer of mortar was evidently a standard Late Classic trait at Tikal, at

least with this variety of masonry; because in Str.5D-38-1st, excavated by the writer, the same type of layer was observed on the wall. The difference is that, here, the course tops are not as level. It was not checked whether or not courses are maintained from wall to adjoining wall.

Joints and Sequence of Vault Construction

Many of the joints were broken although many others were not. There seems to have been no consistent attempt to break them. At the southwest corner the west vault abutted the south vault, indicating that the south vault was built before the west vault. The stones of the east vault face go behind those of the north vault. On the south, the east vault may have been bounded in the third course, but, without removing the gobs of plaster, this was difficult to determine. Poking around could easily have brought down the whole tomb. The north vault could have been the last vault built, if they were built one at a time--something just mentioned as a possibility as the Mayans built by units, one after another. (There is no bonding of the stones of the north vault with either the east or west vaults, although it may be just coincidental). Again, there was no way to check on something like this without possibly causing the tomb to collapse completely.

Most of the stones were laid on edge; but a few, including two large ones on the north side, were laid on their largest surface. Interstices were present without spells.

The bottommost vault stones were not laid directly on the wall top plaster but on a bed of mortar.

No flint or obsidian offerings were present in the fill behind the vault stones (see p. 30).

Masonry Size

The stones of the end vault faces were more uniform in size than those of the north and south vaults, especially the south vault. In the south vault there was a notable difference in size. The only measurements of the depth of the stones were possible in the cut made through the west vault. Here the stones were 56 cm. long on an average and a typical stone was 30 cm. high and 20 cm. wide.

VAULT STONE DIMENSIONS:	HEIGHT	WIDTH	DEPTH (unknown)
	32	24	
	29	26	
	35	24	
	20	22	
	32	30	
	29	38	
	24	16	
	22	24	

Vault Cross Beams

There is a row of three logwood cross beams spanning the width of the tomb. For measurements see p. 36. The wood was of the same variety as that used for the ceiling. The tops of all three beams were not at the same elevation; however, there was only a few centimeters' difference, which

would make it possible for them to have been used to support boards on which the masons would have worked. The modification of the vault stones occasioned by the beams may be seen in the masonry detail elevation. (Figs. 10, 11).

CONSTRUCTION STAGE 1: WOODEN BEAM CEILING

In the only place that was cut through, the east vault, no vault-top pause line was found. It is possible, although unlikely, that one was overlooked. This is because the north side of the cut was used as the main entrance to the tomb and had a wooden stairway and lots of equipment over it. The south side of the trench at this point was not a perfect vertical cut but was hollowed out as a cupboard to hold flashlights, etc. Nowhere was there any evidence to indicate that there had been a break between the vault construction and the laying of the roof timbers, except for the matter of flints and obsidians (see next section).

The excavator was not at all certain of the amount of time separating the construction of the vault from that of the roof. All indications are that the roof was laid while the vault mortar was still wet. Mud mortar, very wet when applied, was used exclusively for the fill behind the walls and vault and directly over the roof beams. In several places over the easternmost roof beam, there was lime mortar--visible in the photograph (Photo 24). It appears that the beam was put there

while the mason still had some lime mortar left over from building the vault; but there is not enough evidence to prove this conclusively.

The ceiling span measurement varied, with a maximum of 1.25 m. The original span was difficult to ascertain because the vaults had buckled. It was too wide for Tikal masons to attempt to span with stone; so, wooden poles were used instead. This type of half-vault and wooden ceiling is rare at Tikal, though it occurs in one of the Temple V roof comb chambers; and, the original temple of Str.5D-42, the "Teotihuacan Structure", may have had a half-vault and wooden ceiling (Chris Jones, pers. comm). Here, there was a large distance to be spanned.

The type of wood used in Bu.196, both for the ceiling and the lower cross beams, is easy to identify by the perfect impressions of the poles left in the once-wet mud mortar. These impressions show that the wood had a characteristically irregular outline. No attempt had been made to smooth the wood to any regular shape. The mud used over the roof poles was so wet that it was easily pushed down between the irregularities of poles. As most of the fill above the ceiling did not collapse, the impressions are still visible today. There are also complete impressions at each end of the pole where the poles sat on the vault tops. In these holes the soft, fragile remains of the wood were still present. Many samples were taken for C_{14} tests, but no tests are planned by the Project.

The total length of a pole was a maximum of 3.45 m. Each end stuck into the fill between .95 and 1.15 m. Most penetrated the fill between 1.05 and 1.10 m. The diameter of the poles varied from 5 to 14 cm., with an average of from 6 to 8 cm. Some of the poles may have been split in half before installation, but this is not absolutely certain from the remains. Between 29 and 32 poles were used. They are so grotesquely shaped and, in many cases, so close together, that it is difficult to tell whether some of the impressions were caused by one or two beams.

Most of the rotted beams which were lying uppermost on the fallen debris appeared to be the vault and wall beams because of their position below the sockets and because they were not covered by roof debris and roof flints and obsidians (see p. 64 about flints). Although there was a little collapsing of the ceiling after the cross beams fell, most of the walls and roof fell in while the cross beams were still strong enough to stay in place and not break under the blows of falling debris. Some of the wall collapsed before the ceiling, although in some areas it appears that the ceiling went first. This is surmised because, in some locations, the wall stones are uppermost in the debris. In other places, the wall stones lay directly on top of offerings.

Because of the extreme irregularity of the poles, it is difficult to tell exactly how close together they were all the way across. Considering the wetness of the mud mortar



Photo 28 Bu. 196, Cellars with the wooden poles fallen, showing flint and obsidian offerings.

and the estimated spaces between parts of the poles it is probable that some mud mortar slopped through--hence the cloth stretched over the tomb (see p. 45).

Towards the middle of the tomb there were burnt spots and charcoal clinging to one of the large stones which had fallen from the ceiling. The writer could detect no copal smell.

STR.5D-73: TIME-SPAN 6 - CONSTRUCTION OF THE PYRAMID

CONSTRUCTION STAGE 12: OFFERINGS OF FLINT AND OBSIDIAN CHIPS

Thousands of flint and obsidian chips were found above the wooden ceiling. This is a special kind of offering which occurs over Early and Late Classic tombs at Uaxactun (Smith, 1950, p. 96) and at Tikal, (Burials 116, 10). The flints and obsidians seem to occur only over and not around or under the burial chamber. All fill has small bits and pieces of flint and obsidian which here are in an obviously ceremonial context.

Above the roof poles the flints were laid right against the wood. What is important to note here is that these offerings occur only above the level of the tomb ceiling but in no case behind the walls and seemingly not behind the vaults. This seems to indicate that to the Mayans there was something special about putting offerings on the roof; and, for this reason, they placed the special chips. This is interesting because constructionally there is no break (no pause layer of mortar over the top of the vault) between the vault and



Photo 29 Centerline tunnel with the author in front of tomb cut in the floor, with the fill retaining wall in the background.

the roof beams.

The fact that no flints occur behind the vault may be used as one argument that the burial was not put in until after the vault was in place. One could ask that if the body, etc. was in place while the vault was being built, why were not the flints and obsidians also put in then? This depends on the exact significance of these offerings--something we can only guess at. Because they touch the roof beams of Bu.196 and because they were directly over the vault stones in Bu.116, their meaning has been interpreted as one of "sealing".

LATER CONSTRUCTION STAGES

After the building of the roof the exact sequence of construction stages becomes difficult to determine. Everything uncovered in Str.5D-73's centerline tunnel indicated that after the tomb roof was finished there was a more or less continuous sequence of building operations (probably up to and including the building platform). One break about which almost nothing is known is the point at which flint and obsidian offerings cease. The first indication that there was a tomb was a fill retaining wall running east-west. This wall turned out to be just south of the tomb cut in Pre-Str.5D-73: Floor B. In general, there were more flints and obsidians the lower and further south the excavations proceeded.

As the writer remembers, the fill retaining wall was found first. Then, the cut in the floor was found (the workmen dug from the top of the tunnel down). The fill retaining wall began about 27 cm. south of the floor cut and appeared to sit on a rough construction layer which is 44 cm. above the level of the cut floor. The fill-retaining wall did not appear to go any lower. Above the floor and, according to memory, thus on the north side of the wall, were found five small flint chips. These were in a trodden-down mortar layer over the floor. It is probable that they were dropped by whoever was putting them in with the fill which was lower and to the south.

It is possible that the construction level on which sits the previously mentioned fill-retaining wall and another fill retaining wall 1.80 m. to the south may mark the end of the flints. However, there is no definite proof that this is so.

Features of the Flint Bearing Fill

Looking up at the fill which covered the roof beams, the base of fill retaining wall was visible running east-west on approximately the centerline of the tomb. This rough wall appeared to stop below a rough construction layer (Fig. 26). However, above this level there was another fill-retaining wall right over it. It does not appear from the section drawing that there was any connection between the two walls.

No specific notes were taken on the fill in which the

flints were placed. During excavation, the flints and obsidians occasionally appeared to be occurring in approximate layers - with a "layer" approximating the height of an average-sized fill stone on its largest surface, under which the flints and obsidians were found nestled in little "caches" (see p. _ _); but, on the sides of the trench after excavation, such layers were not noticeable.

As with the fill in the rest of the 73 Pyramid, all the stones were carefully laid horizontally on their largest surface. The mortar was dark brown and was probably composed predominantly of mud.

Artifacts

The flints and obsidians themselves will be discussed on page . 117A/35 was gathered outside from the wheelbarrow from fill the workmen removed in the fill over the tomb roof and under the level of the floor out through (Fig. 26). Inside the tunnel the lighting was less than perfect; and, although the workmen picked out most of the sherds in the tunnel and put them in marked bags, many artifacts wound up in the wheelbarrow. Outside, both from the wheelbarrow and as it was dumped, all the missed cultural material was gathered and put in a special wheelbarrow lot. There is a chance that sherds from other parts of the building would be accidentally included. Out of the non-flint and obsidian offerings collected, the following objects were interesting

enough to be catalogued:

OP 117A LOT	QUAN- TITY	SUBSTANCE	OBJECT	DIMENSIONS
35	1	Pottery	Reworked sherd (Disk, diam. 2.3 to 2.5 cm.)	
35	1	Pottery	Whistle mouthpiece (L:2.4, W:1.6 cm.)	
35	1	Pottery	Misc. modeled object (Cylinder, 1.9 cm. (Diam. ?))	
22	1	Pottery	Misc. modeled object (Buff, peaked, L:3.8 x Ht:2.1 cm.)	
18	-	Bone	Small fragments, all less than 2 cm. long.	
19	1	Bone	Worked, (Shaft with groove, L:8.2 cm.)	
21	1	Bone	Fragment	
25	1	Bone	Needle (eye, L:2.9 cm.)	
25	1	Bone	Worked. (Small polished cylinder L:3.2 cm.)	
26	2	Bone	Animal, unworked. (Part of jaw- deer?)	
18	1	Shell	Small fragment of burned shell. (1 x 1 cm.)	

BASAL PLATFORM

It seems probable that the basal platform was erected after or at the same time as the tomb was installed, for the reasons given on page 19. The limits of the old Great Plaza, of which the basal platform is an extension, are not known. The Great Plaza seems to have extended at least as

far south and west as where the tomb cut was sunk.

The basal platform is two terraces high and of simple design. Each terrace top is from 70 to 80 cm. wide, and the upper terrace is approximately 1.05 m. high. The height of the lower terrace varies according to the elevation of the base surface; its height is a maximum of 3.20 m. (at the southeast corner) and a minimum of 1.85 m. (at the northeast corner). There are no moldings or side outsets on the basal platform. There is a rear outset, but it appears to have been a secondary addition. The outset was buried under tons of fallen masonry and was high on the priority list of excavations.

The basal platform facing has a northern termination, on the west, approximately in line with the northwest corner of the pyramid. Here, the platform forms an interior corner, as there is an east-west facing which continues about 15 m. westward and then turns north to run behind Temple II (Carr, 1961, Great Plaza). Between Str.5D-73 and Temple II the great Tozzer Causeway begins. Thus, there is no "basal platform" on the front of 73.

The northern termination of the east side of the basal platform occurs about one-third of the way north from the southeast corner. Here, it ends where abutted by the east-west running basal platform of Str.5D-72-1st.

Although it could not be extensively checked, from what little excavation was done on the west side, it appeared that

the basal platform of 73 was built at the same time as the plaza extension (which supports Temple II ?). The stones of the 73 platform all went behind those of the other terrace. To see how far the basal platform of 73 continued to the north(west), a trench was dug through the abutting Great Plaza retaining wall. The facing of 73 did not go more than one stone's length past the Great Plaza facing. It appears that the two walls are thus contemporary, to a certain extent.

On the east side of 73's basal platform, it seems that the facings of Str.5D-73's and 72's-1st's basal platforms were bonded. However, this corner was deep within the tunnel system and was not thoroughly investigated.

Masonry

The masonry is typical Tikal Late Classic large "ve-neer" with an approximate alternation between headers and stretchers (memory).

Complications

In the south centerline trench evidence was uncovered suggesting that there had been additions to the building platform perhaps creating a rear center outset. After the author left Tikal in early 1966, R. Larios spent some time on this problem; but, because it was not a crucial point, extensive excavation was not undertaken. This addition was 80 cm. wide. Neither its exact height nor its extent are known.

CONSTRUCTION STAGE 10: 4th MASON'S STAIRWAY

For practical reasons, the discussion of what was uncovered in the centerline tunnel is divided up by four construction stairways. A construction or mason's stairway is a common, typically Late Classic, feature of the large Late Classic temples. It is characterized by its rough, unplastered appearance. Often the treads are covered with down-trodden mortar spilled by masons as they carried their loads up to the pyramid top. The purpose of these rough stairways was twofold. Firstly, they saved the final stairway which was carefully plastered and sometimes painted, from a considerable amount of wear and tear. Secondly, the final stair was too far out in front of the core of the pyramid to service the construction levels (see p. _ _).

Whatever notes originally existed on the 4th construction stairway have been lost, but the writer can remember several things about them. This stair was not actually cut through by the Op.117A centerline tunnel because, here, the tomb robbery tunnel had gotten there first, cutting through the bottom four steps (Fig. 24). At first, the writer thought that these were steps belonging to an earlier pyramid, because they were relatively well-made and the location was too far back within the core of the pyramid to expect a construction stairway.

The stairway was built 6 cm. above the level of the floor

(Pre-Str.5D-73: Floor A) on which was built 73. An interesting fact here is that the construction level (Str.5D-73: Unit C) turns up to the stair. The rough layer of trampled-down (?) mortar forming this level is about 10 cm. thick, resting directly on the base surface floor. Str.5D-73: Unit C itself is the base surface for the northernmost three construction stairway and the final stairway (Fig. 26). The fact that this level turns up to the 4th construction stair hints that this stair may already have been in existence prior to Str.5D-73(-1st). In the centerline section (Fig. 26) the turn-up to the bottom of the stair is shown in broken line, because the actual turn-up is only visible off-section a few centimeters. At this point in the centerline tunnel the tomb robbery tunnel had removed part of the stair.

Twelve steps, a total of 3.70 in height, were excavated. This height is greater than that of the centerline tunnel. The excavator thought that, since this stair was so far back inside the core of the pyramid, it might only go up one terrace level. From the outside of the pyramid, it was known that the top of the first terrace was at an elevation of approximately 254 m. In the tunnel a horizontal layer of mortar was found at an elevation of at 253.50 with another layer at 253.60. The bottom of these two was probably the 1st terrace top mortar pause-layer. (From excavations on Str.5D-33 and elsewhere, it is known that Late Classic temple pyramids at Tikal were built up in horizontal layers, each layer

corresponding to one terrace approximately 2 to 3 m. in height. As each layer was finished, it was covered with a layer of white lime mortar.

Masonry

The majority of the riser stones were rectangular stretchers. A few headers were observed. A typical step was 30 cm. high, 20 cm. deep. At first, the excavator thought the stair was a finish stair for an early building. There was, however, absolutely no trace of plaster on the risers or treads. What was covering the treads and had occasionally dribbled down the front of the risers was the trodden down mortar that is often found on masons' stairs. This deposit is thickest on the nose of the treads. Many of the stones appeared to have been installed in a typically tilted position (in order to achieve the desired batter for the riser).

Fill South of Str.5D-73: 4th Masons' Stair

There did not appear to be much difference between the fill behind the stair and the fill in front, except that just in front of the tomb cut in the floor there were some very large stones. These and all the fill stones were laid horizontally on their largest surface. One of the largest fill stones was 75 x 20 cm. in cross-section.

Artifacts

Most of the fill in this vicinity had been removed by the robbery cut. 117A/13 was from near the floor (in trampled down mortar ?) just north of the cut for the tomb. Here was found the first sure proof that there was a tomb--the floor cut and flint chips. The flint chips appear to have been dropped, as their proper provenience is on the south side of the fill retaining wall over the edge of the tomb cut. There were 5 unmodified flint flakes, each ca. 3 x 2 cm. For the artifacts found in the silt of the robbery tunnel, see p. 109.

CONSTRUCTION STAGE 92 PARTIAL RIP-OUT

One thing which could not be understood was that the 4th stair was only visible on one side of the centerline tunnel; this was further complicated by the fact that at this point the robbery cut (see p. 107) had removed much of the stair. The lowest steps were clearly visible on the west side of the cut as far up as the limit of excavation. On the east side of the robbery cut, however, the stairs were not there. That there had been something going on here is known from the mortar layer (Str.5D-73: Unit C) which on the west side of the tunnel turns up to the base of the stair. On the east side of the robbery cut, where there is no stair, this level keeps going about 1 m. until it finally just stops. At this

point, perplexingly, there is no out-line or discontinuity in the fill which would conclusively indicate a rip-out.

This is one of the several instances in the Str.5D-73 investigations where the extremely limited amount of time and the number of workmen made it impossible to attempt to solve all the problems which arose. It would have been interesting to have dug up about 50 cm. above the top level of the robbery cut and centerline tunnel to uncover a complete step running the width of the centerline tunnel. Then, without cutting away the step, the step itself could have been followed west to where it either came to its normal termination, perhaps to a rough stair side-wall or to where it had been partially scooped out.

The only explanation that the author can give is that, if there had been a rip-out, the step stones, being roughly rectangular, were removed to be used elsewhere. If it were a mason's stair, the rip-out would have occurred just after the stair had outlived its usefulness and just before it was to be covered by fill.

CONSTRUCTION STAGE 8:

LAYING OF A ROUGH "FLOOR" TURNING UP TO RIP-OUT

After a portion of the stairway was removed a 12 cm. deep layer of lime mortar was laid, abutting the rip-out and the stairway where it was preserved.



Photo 30 str. 10-73: 3rd masons' stair.

CONSTRUCTION STAGE 7: 3rd MASONS' STAIR

The front of this stair is 10.04 m. back from the final front stair, which puts it over 4 m. inside the fill of the actual pyramid and further back than a construction stairway would be expected. The stair was the most crudely constructed of the four, each step being of a slightly different size and without any discernable regular pattern. This is partially a result of the fact that no specialized stones were used. That it was a stairway was obvious (Photo 30), especially from its bottom steps. The bottom five or six steps have low, 23 cm. risers and manageable treads, 25 cm. The next four steps have very narrow treads (15 cm.). An 11th step was not found, but two more are postulated to enable the stairway to arrive at the 1st terrace top construction pause-layer. The tomb robbery tunnel cut through the bottom four steps on the east side of the centerline tunnel.

Masonry

The basic shape of the steps is only approximately rectangular; and the stones, only roughly finished, are mostly stretchers set on their largest surface to form a single-block riser construction utilizing many vertical and horizontal spalls. There is no finish plaster and the risers are slightly battered. All the treads slope due to the layer of mortar, which may have been dropped and trodden down by masons as they climbed the stair. Riser-tread overlap occurs

only in the upper steps, where the treads are not very deep. There is never any contact between the riser and tread stones themselves; mortar intervenes.

Fill

There were no horizontal layers of fill visible below the 1st terrace top construction layer. This layer, 3 cm. thick, occurred 3.20 m. up from the base surface; it continues south and turns up to the 4th construction stairway. The 3rd construction stair appears to rest on top of the layer of mortar 12 cm. thick which lies over the base floor. The stair was thus built on the same level as the other two northern masons' stairs (Fig. 26).

The fill consists of stones of all sizes, with small ones (12 x 5 cm. cross section) predominant. All the stones rest on their largest surfaces; mortar is of the mud variety.

Above the 1st terrace top pause level was discovered the hollow cast of a logwood beam, 10 cm. in diameter and approximately 85 cm. long. Its south end may have touched the 4th masons' stair. On the sides of the tomb robbery cut there were several other impressions of logwood poles, usually running north - south (memory). Some of the poles may have been on the south side of the 4th construction stairway as well, but the author cannot remember. Wood poles frequently are found in the fill of Late Classic structures at Tikal; but, as yet, no definite significance has been attached to

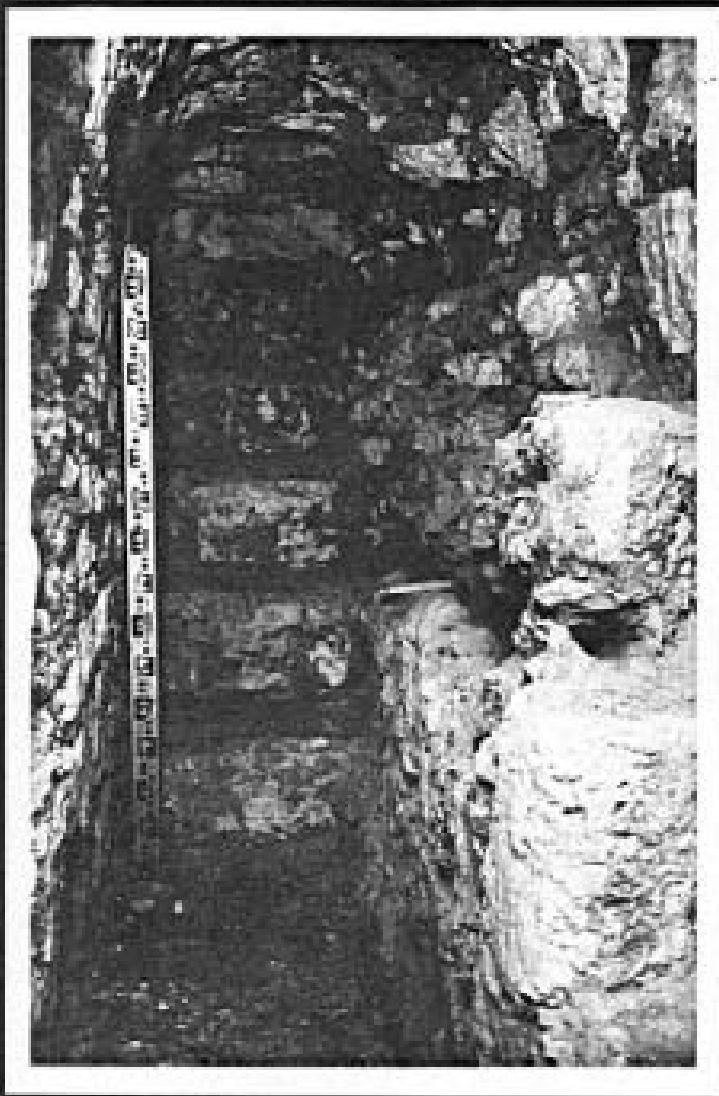

Photo 31 Str. 5D-73, 2nd masons' stair in the background with the 1st masons' stair with pole hole in foreground.

their occurrence. The fact that most of the poles seem to have been in front of stairways may have some meaning. Perhaps they were used in a pulley system or as scaffolding.

Artifacts

The artifacts uncovered from the fill behind the 3rd stair were bagged as 117A/4. Very few sherds were uncovered and there was nothing interesting enough to have been cataloged.

CONSTRUCTION STAGE 6: 2nd MASONS' STAIR

There are 6.20 m. separating the 2nd from the 3rd construction stairways. The 2nd stair is clearly part of the 'final stage' 73, as it is buried by (final) stairway fill, not pyramid fill.

The mortar layer that supports the 3rd masons' stair appears to give out to the north and does not sustain the 2nd stair. Instead, the 2nd stair sits on a lower mortar layer, 7 cm. off the base floor; 1.10 m. north of the base of the stair is a roughly circular burnt area, 10 cm. in diameter, with several other adjacent burnt areas.

Masonry

The stones used were roughly-finished rectangular blocks. No finish plaster was evident, but the treads had the usual hard-packed layer of grey lime mortar, which occasionally

spills over down the risers. Stair stones were very soft, and of single-block riser construction, the risers appearing slightly battered. There was no slope to the stones themselves, as there was to the mortar layer on them. According to memory, all the stones were stretchers.

DIMENSIONS	Length	Height	Depth
(in cm.)	62	27	20
	50	32	22

Fill

There were several horizontal divisions of the fill. One such division occurs at the level of the top of the fourth step. This level appears to run all the way to the next masons' stair to the south. Large stones (max. 84 x 20 cm. cross section) were more abundant than small; and almost all the stones lay on their largest surface. In front of the stair lay Problematical Deposit 171 (Op. 117A/38) (see P. 79). Several horizontal logwood beams lay just in front of the stair (see p.78).

Artifacts

From the 1 lb. 10 oz. of artifacts in the fill, the only object of interest was a 2 cm. long fragment of a long bone, probably animal.

CONSTRUCTION STAGE 5: 1st MASONS' STAIR

The bottom step rests on 16 cm. of fill which, in turn, rests on a 4 cm. thick layer of mortar over the base floor. The author has no explanation as to why the step begins this high up. Only five steps were unearthed. It was a rough mason's stair, 2.08 m. behind the final stairway.

Masonry

The step stones were rectangular blocks, only roughly finished. The top edges of the stretchers were not noticeably rounded or squared-off, while the headers were slightly beveled in front. The stairway was unplastered, although it had the usual layer of mortar on the treads; all the stones were set on edge. In the small section of stair which was exposed, headers alternated with stretchers. The width of the headers varied; among them were some very thin ones. The construction was single-block riser. Where logwood poles protruded, there were often small stones in the face of the riser (Fig. 15).

Fill

The fill was similar to that behind the other stairs except that it contained fewer large, thin, stones.

Wooden Poles in Fill

At the bottom of the third step, there was a nearly

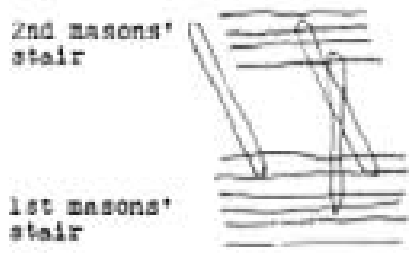

a Sketch plan of wooden poles.

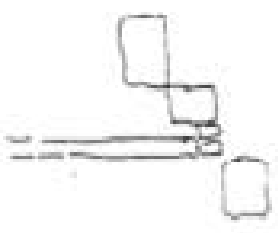

b Sketch section of wooden pole.

Fig. 15 Sketch plan and section of wooden poles in fill.

tubular hole. This was the now-empty space where originally there had been a wooden pole laid horizontally. Traces of wood powder remained on the bottom of the cast. Because of the irregular cross section of the sides of the cast, the wood that was once present was easily identifiable as logwood. The pole had a minimum length of 1.80 m. with a diameter of 7 cm. and lay in a position parallel to the centerline tunnel. Whether it went past the front of the 1st masons' stair is not known, because the workmen removed the fill here before the author noticed the pole hole in the third step.

Behind the fourth and fifth step, two other well-preserved wood holes were found: one on the east side of the tunnel, the other on the west (Fig. 15). By the time the east hole had been noticed, its north end had been chopped away. What remained of the hole extended 1.45 m. into the fill at an angle off to the east. It was not parallel to the other two poles. The hole was approximately horizontal and had a diameter of 11 cm.

The western hole had soft powder in it: evidence of decayed wood; its diameter was 6 cm. The space runs approximately level and abuts the front of the fifth step of the 2nd construction stair. Its length is 1.70 m. The pole may originally have been longer, going through the 1st masons' stair to the north.

Wooden poles in fill are also known from Uaxactun (Smith, 1950, Fig. 73) and from other structures at Tikal (Shook, pers comm.).

Artifacts

117A/2 contained two used flint flakes and one small, used obsidian-flake blade. There were also a few sherds which have not yet been studied.

PROBLEMATICAL DEPOSIT 171

In a small area from 1 to 55 cm. north of the base of the 2nd masons' stair, were numerous fragments of a deliberately (?) -smashed censor. As this is on the centerline, it is possible that there is some ritual significance to this destruction. The fragments lay directly on the base floor with a few tiny bits of charcoal. The highest fragment of censor was 3 cm. off the floor. All the fragments were encased in the mud mortar which formed one of the many layers of mortar on which the masons' stair were built.

At this particular point three layers of mud mortar could be distinguished; two abutted the bottom step of the stair, one passed underneath. Although it does not say so specifically in the notes, it would appear that the fragments were in the bottom layer and thus may be unconnected with the stair. The author does not yet have available any description of the fragments nor any information on whether this was a common practice.

CONSTRUCTION STAGE 4: PYRAMID FACING MASONRY

Ground Plan

The ground plan of Str.5D-73 is very similar but not identical to that of other Late Classic temple-pyramids at Tikal. Outsets and insets are always relative to a point of view. The rear of 73 was the most destroyed; and the reconstruction of the rear outset is hypothetical, based on the fragments of evidence available. A study of all the patterns of rear outsets on Late Classic Tikal structures by H. S. Lorton may help to provide a better reconstruction. That there is a rear outset at all is known from the little remaining evidence. B. Larios does not place a rear outset on the building platform, but Dr. Coe believes that there should be one. Hopefully, the author will be able to return to Tikal in the coming summer and solve problems such as this. At the moment, the plan is left as drawn in the field.

The inset stairways are an unusual feature; but their authenticity is assured by conclusive evidence (see p. 82) and their presence on the better-preserved Temple I.

The side outset was perfectly preserved on the east side and on the northwest corner of the west side. The reconstruction of the front of the upper terraces is based on the plan of the lower terraces, which were perfectly preserved and thoroughly excavated on the east side of the central stairway. After 10 years of work at Tikal, enough is known about the architecture of temple-pyramids to reconstruct

original appearance on much less evidence than is available for Str.5D-73.

There is a slight difference between Temple I and Str.5D-73 in the proportion and placement of the front outsets. On Temple I, the outset next to the central stair protrudes considerably more than the other outset and considerably more than the outsets of 73 (Fig. --). In addition, the center outset of the second (front) terrace projects past the plane of the outsets of the lower terrace, an arrangement which does not occur on 73.

Facing Masonry

The facing masonry of all the front terraces, and presumably all the rest of 73, was laid before the final stair's side-wall was built. At this time, the final masons' stair was probably the method of ascent. It is not known whether all or part of the building platform was built before the pyramid was finished, but, for organizational reasons, all information on the building platform is put together starting on page 95.

That the pyramid facing masonry went on before the final stair side-wall is known from other pyramids (Str.5D-33-1st, Temple I). Along the entire east side of the stair side-wall, a north-south trench cleared all five terraces of Str.5D-73. Here, it could be seen that the pyramid masonry went behind the masonry of the stair side wall to a considerable extent



Photo 32 South side of Temple I with 'step-insets' barely visible.

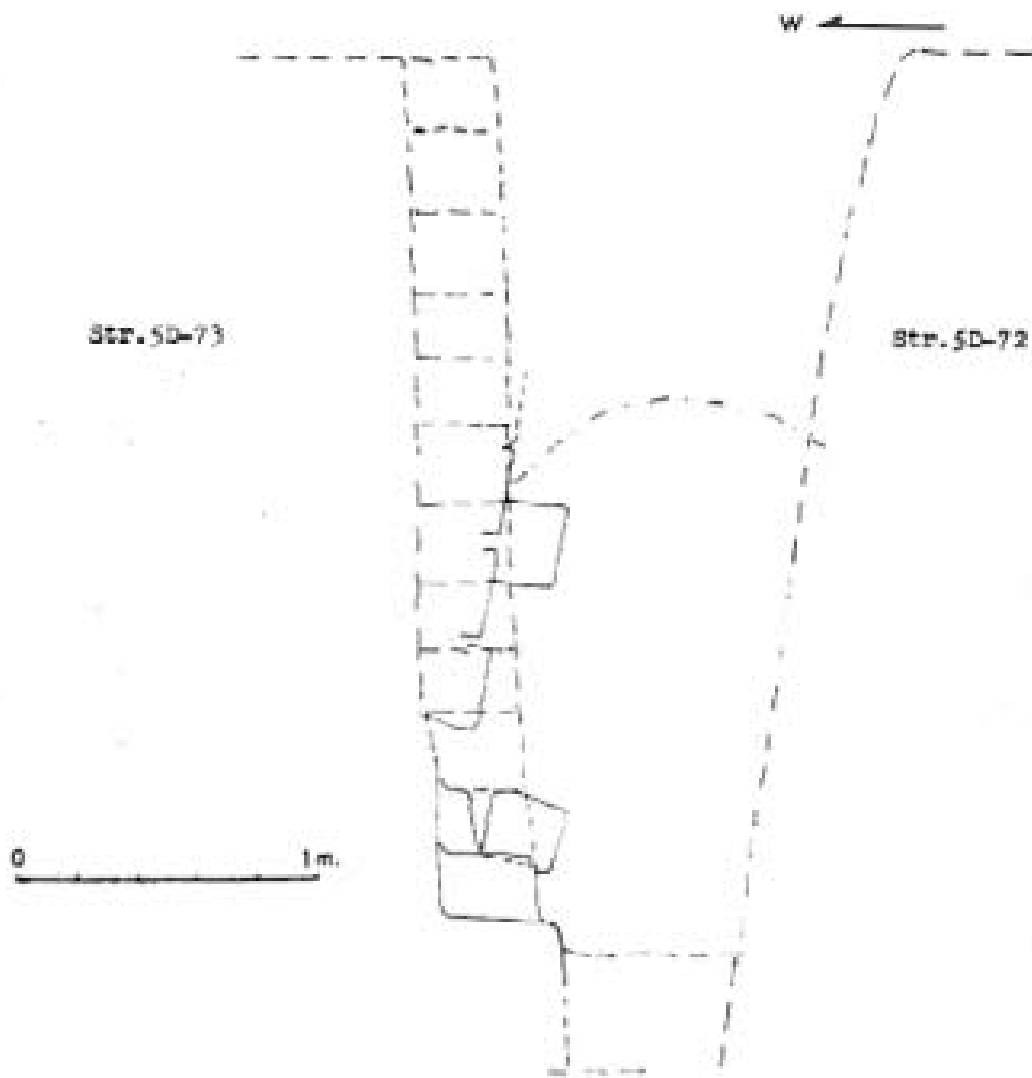

Fig. 16 Str. 5D-73, east side, lowest terrace, looking north at a south elevation of the step-terrace with the steps also shown in section (east-west); Str. 5D-72 is shown in profile. Scale 1:20

Fig. 17. Shp. 50-71, east side (see sketch).
Lower spread terrace, east elevation and
west profile. Scale 1:100

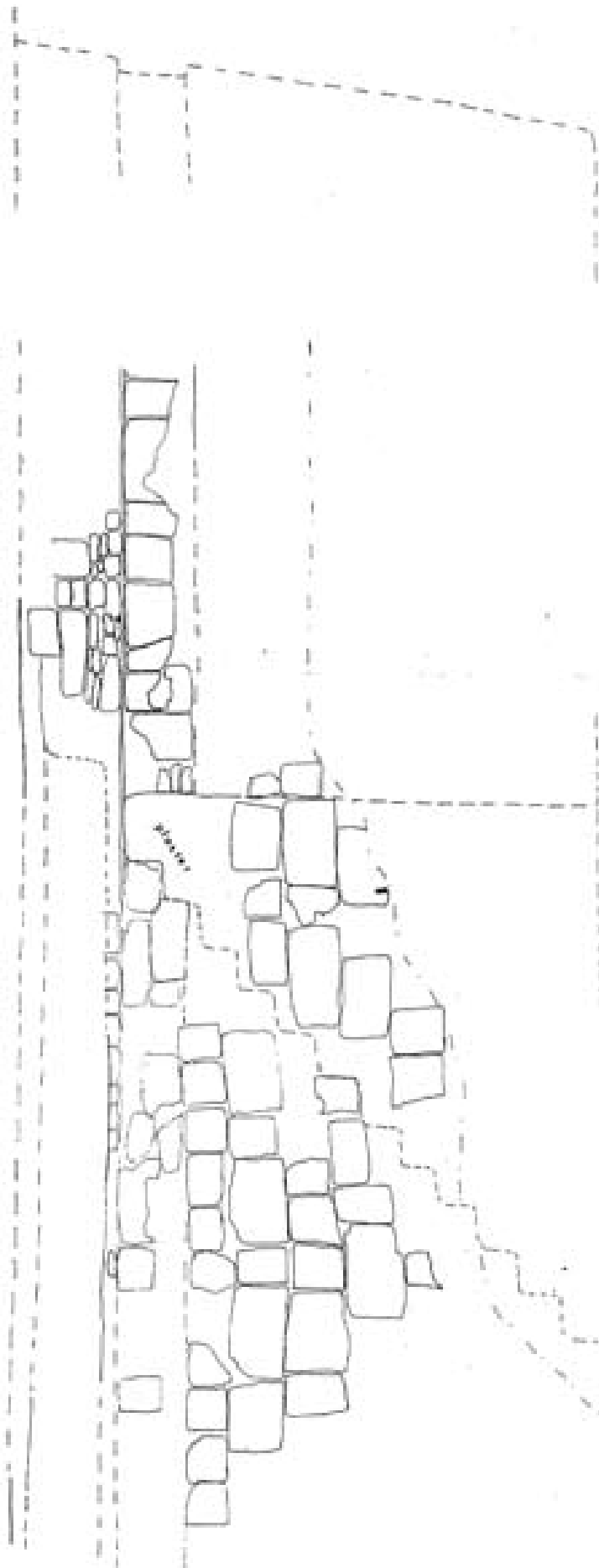

Fig. 18. Shp. 50-71, east side, lower spread
terrace, east masonry detail elevation.

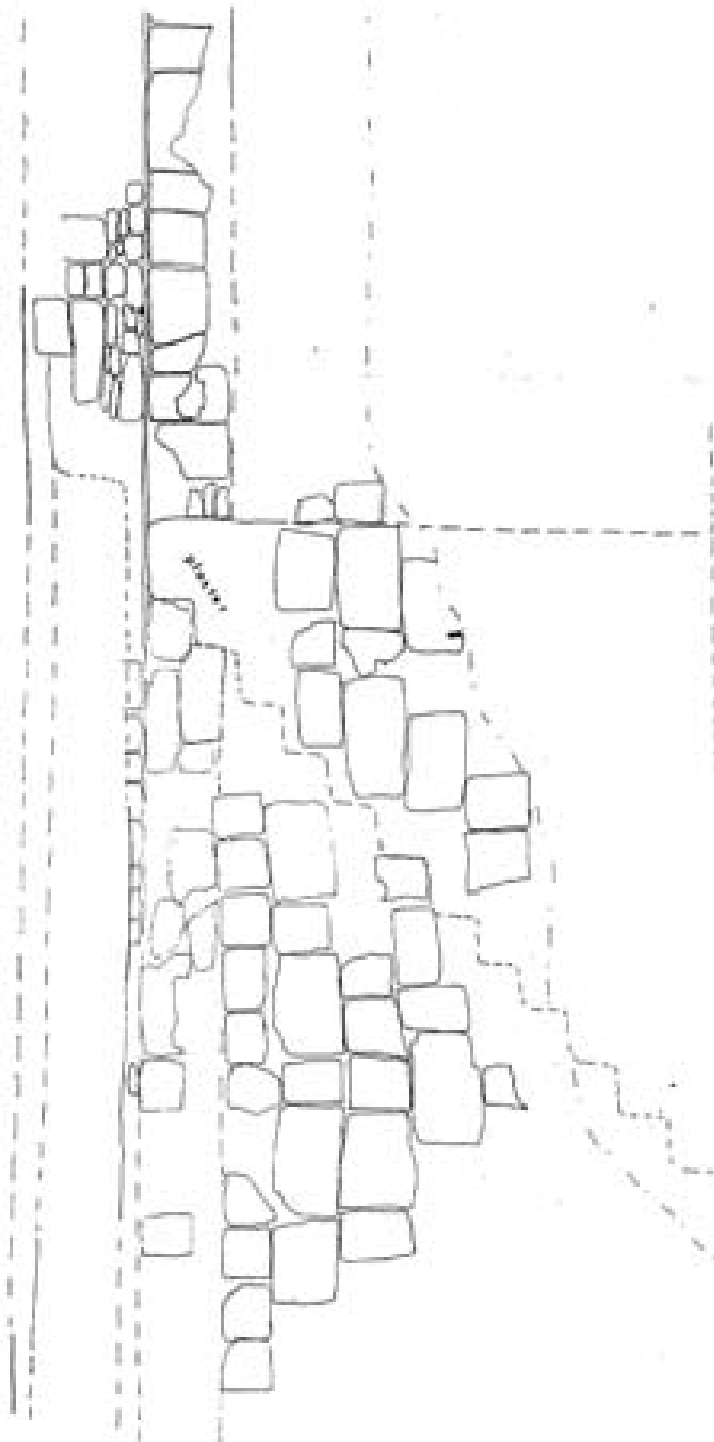
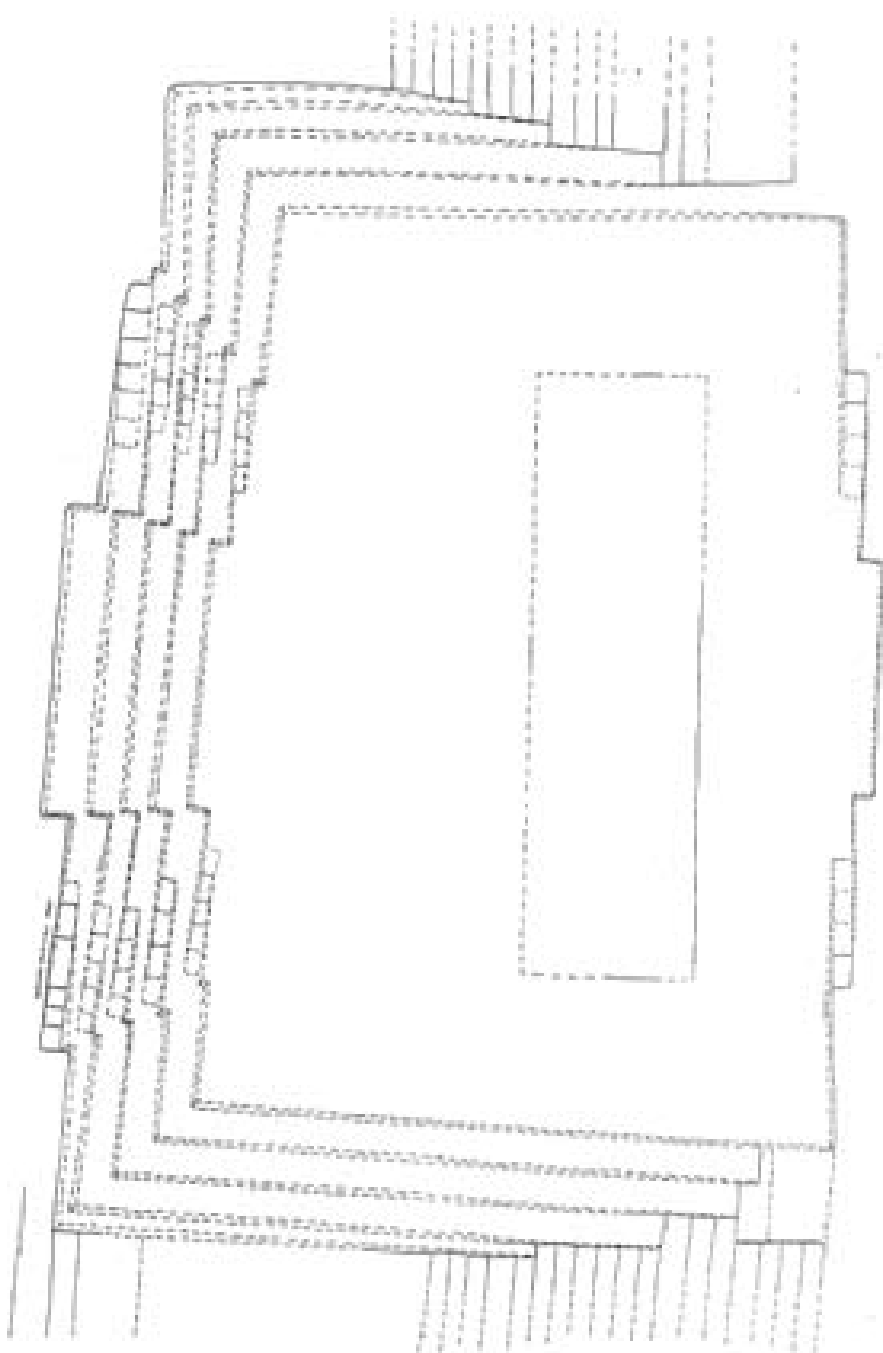

FIG. 18 B STR.5D-37-B, PLAN

FIG. 18 C STR.5D-37-B, EAST ELEVATION



N

FIG. 18 B STR. 5D-37-B . PLAN

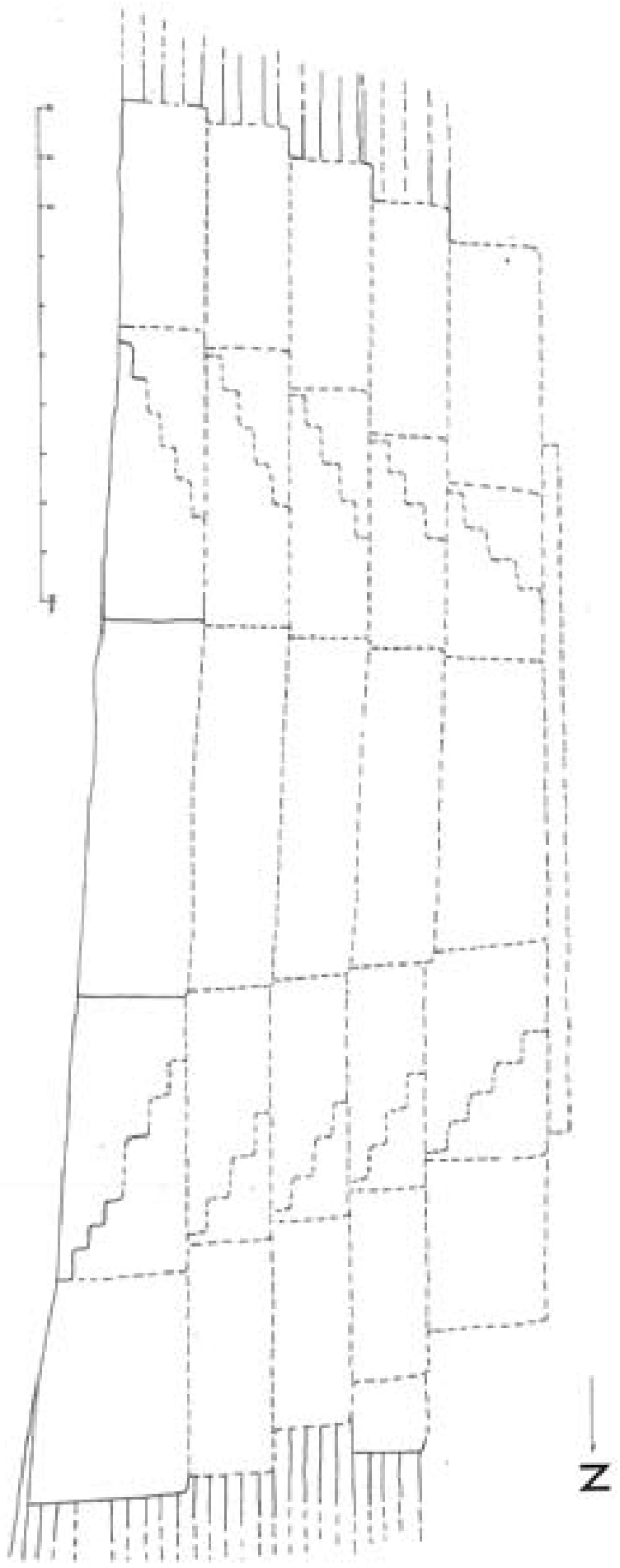

FIG. 18C

STR. 5D-37-B, EAST ELEVATION

REPRODUCED FROM ARCHITECTURAL RECORDS SCALE 1/8"

(Fig. 20). Even the moldings of the pyramid facing continued behind the stair side-wall, (probably until they abutted the stair side wall of masons; stair #1).

The place where most of the facing masonry was exposed was in the dark, and potentially-collapsible, tunnel between 73 and 72. The two masonry detail elevations drawn by R. Larrios (Figs. 18, 20) may be taken as representative of the general type of stone used. In addition, some idea may be gathered from the sections.

In the terminology of L. Smith at Uaxactun, the masonry may be considered "veneer" masonry.

STEP-INSET

When the author was excavating the south end of Str. 5D-38, he uncovered parts of the bottom terrace of Temple I's pyramid near its northeast corner. A strange inset was found on Temple I which the author had never before seen on a Mayan structure. Simply, it consisted of a set of diminutive steps set into the pyramid facing. The tiny steps ran up parallel to the side of the pyramid, going away from the nearest corner. Upon closer observation of the rest of the pyramid, these unique step-insets could be seen on almost every terrace, one to a terrace. They alternated east-west positions by terraces, i.e., on the bottom terrace the step-inset is near the east corner; on the second terrace the step-inset is near the west corner, etc. It is possible that

on Temple I there were none of these step-insets on the upper (two ?) terraces (Coe, 1966, pers. comm.) and Fig. --. The step-insets only occur on the sides of the pyramid, not on the front or back.

Step-insets do not occur on Temple II. They were specifically looked for on Temple IV but do not occur there either (Pearson, 1966, pers. comm.). Such a slightly different type of step-terrace occurs on Str.5D-37, excavated by the author (see p. 35, Fig.18b). Insets have not been noticed on any other Mayan temple, although it would be extremely easy to miss them, mainly because they are not expected - at first they look like stones fallen out of position unless the plaster is preserved on the steps. Step-insets will be missed if only the corners of a structure are excavated.

When it became apparent to the author that Str.5D-73 was architecturally similar to Temple I, he decided to look for step-insets on 73. This was one of the reasons for digging the extensive tunnel between Str.5D-73 and Str.5D-72 (see P. 11).

A step-inset was uncovered by the author precisely where it was expected; north of the southeast corner of the east side. This was the only one on the whole pyramid which was looked for, because, due to its situation buried by protective debris, it was the only one which would be relatively intact. The actual recording of this feature was done by R.

Larios, because the author had to return to school.

The steps were inset 6 cm. from the top edge of the basal molding. They were 32 cm. wide with a 20 cm. riser and a 22 cm. tread. Twelve steps extending all the way to the top of the terrace are postulated by Larios on the basis of remaining evidence. According to memory, the Temple I step-inset did not appear to go up this far per terrace; nor did they begin below the basal molding but sprang from the top of the basal molding.

On the Str.5D-73 steps, the bottom two steps were well-preserved and had enough plaster remaining to prove that this was not a case of pushed-out or broken-off stones. Also, what would have formed a sixth step was still partially in place. The terrace facing in the vicinity of the inset stair was slightly fallen out (Fig. 18a), but the stones were in position relative to one another.

Before the author uncovered the step-insets on Strs. 5D-1 and -73, he had uncovered steps (possibly) of a similar nature on Str.5D-37, in the East Plaza, not far from Temple I or Str.5D-73. The full description of Str.5D-37 has been written by the author and will be published by the University Museum, University of Pennsylvania in TIKAL REPORT 16: EXCAVATIONS IN THE EAST PLAZA OF TIKAL. As this will not appear for several years, below is the section on the "step terrace outset".

STEP-TERRACE OUTSETS, EAST SIDE, STR.5D-37

As the writer is unaware of another system of stairways exactly like that of Str.5D-37, a name was devised for them: "step-terrace outset". Each term is important. There are steps, from 45 to 56 cm. wide, approximately 70 cm. deep, which go up parallel to the front of the structure (east side) They occur in terraced; rather than going all the way directly from the bottom to top of the whole pyramid the steps go up in "flights", one flight for each of the five terraces. Finally, they are outset stairways, partially projecting sideways, as opposed to being completely inset as those of Str.5D-73 and Temple I. Each "flight" thus has one stair side-wall and one stair-inset wall. On the west side the structure is only one terrace high and the exact form of the step-terrace is clear. On the front, there are five terrace levels; the exact arrangement of step-terraces on the upper terraces is not at all clear.

Discovery of the Step-Terrace Outsets

The first of these unusual stairways was uncovered while looking for the northwest corner of Str.5D-134. The northwest corner of Str.5D-134 was very close to 37. A trench was started parallel to 37 next to the place where the front of 37 was expected to be. A wall was soon found, followed by a single, projecting stone next to the floor. Fortunately, preservation was excellent. There was plaster preserved on

top of this stone turning up to 37 and turning up to another projecting stone higher up. The floor also turned up both to the wall of 37 and to the bottom projecting stone. Such plaster turn-ups showed that these were definitely not just fallen stones. Because the author was completely at a loss as to how to explain this, the whole area was cleared from this point to the already-cleared center stair stair-side wall. This same trench also uncovered the northwest corner of Str.5D-134, the original object of the search.

Even when fully uncovered, this construction was perplexing. Tracing the wall to the south, another outset was found. This new outset was so small that at first the writer could not perceive what purpose it served. One hypothesis, later to be disproved, was that some of these outssets may have been the result of different building periods.

The next move was to excavate the entire front (base) of the pyramid from the north stair-side wall to the northwest corner to uncover all the outssets. More important, this would allow floors to be traced from under the center stairway all the way to under the Maler Causeway parapets. On the south side of the stairway Str.5D-123 was already related to Str. 5D-37 floors. Thus, 123 could be related to the causeway.

East Side South Step:Terrace Outset

The 1st terrace's step-terrace outset south of the south stair-side wall of the front central stairway will simply be

called the south step-terrace. This stairway is 5.60 m. long and consists of six equal sized steps (Fig. 18c). Of this length, 2 m. are taken up by a landing at the top of the terrace. The bottom step is a maximum of 35 cm. high, varies from 52 to 55 cm. in width and has a 72 cm. deep tread (Photo #5). Plaza 5D-3: Floor B turns up to the front and side of this step, as well as to the rest of Str. 5D-37. Plaza 5D-3: Floor C sustains both the step and all the rest of Str. 37, except for the front center stairway. Plaster still remains in one corner on this step. This plaster turns up to the stair inset wall and to the riser of step #2. The second step is 25 cm. high, from 53 to 57 cm. wide, and extends 66 cm. There is no plaster left on the tread. The third step is about 27 cm. high, 57 cm. wide, and 74 cm. deep. Nothing is left of the other steps.

Step Masonry

The risers are single block stretchers. The bottom riser abuts the stair-inset wall, but the wall does not go much further behind at this level. The riser of the second step goes into the stair-inset wall, which passes slightly beyond the riser of the third step. The riser of the fourth step goes into the stair-inset wall. These facts suggest that the stair-inset wall was built at the same time as the step-terrace outset. This is important because the stair-inset wall is merely the east face of the diminutive stair-

inset-wall outset.

Side-Wall Masonry

The stones used in both the stair-inset wall and the stair-side wall were typical Tikal Late Classic veneer stones. The following description is primarily of the stair side wall, because only about six stones of the stair-inset wall are left. Coursing was present but not perfectly horizontal. Masonry size was uniform except on the top course. Here, the stones were smaller and were used to level the top of the wall. (The same phenomenon occurs on Str. 5D-38-1st) Narrow interstices were common both vertically and horizontally, with very neat little spall stones. Not all joints were broken. The corner with the center outset seemed to be partially bonded. There was one interesting masonry note about the stairway: the end of the bottom step riser was part of the stair side-wall. The riser of the second step, however, which ran into the stair-inset wall, did not go as far as the stair side-wall, and so on. There seems to have been an alternation of stones producing a bonding effect. The stair side-wall was battered increasingly as the wall went up. The batter of the stair-inset wall is not known.

EAST SIDE NORTH STEP-TERRACE OUTSET

The lowest step-terrace north of the centerline on the east side was better preserved than the south step-terrace.

None of the step-terraces on the upper four terraces was preserved. This 1st terrace stairway consisted of seven steps, as opposed to the six steps of the south step-terrace. The additional step was necessary because 37 was built on a sloping base surface. The base of the north side of the structure was about two meters lower than the base of the south side (Fig. 18c). Another difference in this step-terrace was that it was slightly modified at a late date. This modification consisted in extending the stairway 50 cm. northward--an extension reflected in step #4 which is about 50 cm. longer than it should be. This modification caused the stairway to cover up the diminutive outset of the corner of the stair-inset wall. Otherwise, this stairway was basically the same as the south step-terrace.

Of this step-terrace, six steps remain. In no instance is there any plaster surface remaining. The stair-side wall has buckled and the steps have been pushed down by roots; but the shape and character of the stairway were quite obvious. The depth of the tread was not greatly affected by the wall's buckling and could be measured directly; at the bottom. The width of the stairway was 54 cm. Nowhere else was it directly measurable, due to the buckling of both the stair-side wall and stair-inset wall.

The front of the bottom step was flush with the front of the stair-inset-wall outset, as a result of the secondary repair to the stair. The riser was 79 cm. wide, consisting

of a stretcher and header, although the actual width of the step measured 5# cm. with the inseting (or outseting depending on one's viewpoint) of the stair-inset wall being 25 cm. The arrangement of stones to form the riser was rather unusual. The riser was two courses high, the bottom course consisting of large, spall stones. The top course was a typical Tikal Late Classic veneer stone used as a stretcher. In side elevation this step was sheathed by a stretcher (a header to the step stretcher to the wall). The step stretcher bonds with the stair-inset wall. This bottom step was 61 cm. deep.

Step #2 was 55 cm. deep. Its riser was similar to step 1, (one course only) was being formed partially by a stone of the stair side wall (stretcher to the stair side wall, header to the step). The second riser stone was a stretcher bonding with the stair-inset wall.

Step #3 was 52 cm. deep. The riser was one stone whose end shows in the stair-side wall (header to stair-side wall, stretcher to the stairway), thus abutting the stair-inset wall.

Step #4 is about 1.3 cm. deep. This was originally of more regular size but was lengthened when the stairway was modified in later times.

Step #5 seems to have been over 60 cm. deep, but the steps are pushed too far out for accurate measurements. The

riser may have been bonded 91 with the stair-inset wall.

Step #6 was the last step still in place. The riser stone was extremely long and must have bonded with the stair-inset wall. At this point the stair-inset wall had collapsed.

Step #7 probably rose the final 30 cm. to a landing at the top of the 1st terrace. This landing was about 1.80 m. long by 80 cm. wide. When the center stairway was added this was shortened at the south end by 20 cm.

The exact dimensions of these steps could not be measured. The elevations of the top of the steps were determined by the top of the stair-side wall which could never be higher than the adjacent step. Although the stair-side wall was slightly fallen outward, its original height could easily be reconstructed from measurements of the stones.

EAST SIDE UPPER LEVEL STEP-TERRACE OUTSETS

On the front of 37, very little of the upper level pyramid facing was preserved. Only parts of the central outset survived, due to its having been buried below the secondary stairway. A few stones of the 2nd terrace of the step-terrace remained in the protected corners next to the central outset. The question remained: did these step-terraces go terrace by terrace all the way to the top; and, if so, how were they arranged?

Neither of the two flanking stairways provided direct access to the top of 37. The west side step-terraces, having

only one terrace to surmount, did provide direct access to the top. Because of an interesting design feature (see next section) and because of the probable function of the structure as a focus of movement, activity, the writer believes that the front step-terraces extended all the way to the top. Besides, why not? It was just a novel approach and shows that the Mayan architects were not completely static in their design.

Stair Inset-wall Outsets

The interesting design feature is the 25 cm. wide outset, which was a continuation of the stair-inset wall. On the west of 37 this extra outset was not present because it was not needed. On the west side of 37 the top of the "first" terrace was the top of the pyramid. On the front, once one has climbed up the first terrace, there are four more to go. In designing a system of step-terraces, there are two alternatives: The stairways can alternate positions (Fig. 22c), or they can be the same for every terrace. Alternating positions would mean that at the top of the second flight one would have to remember not to walk straight ahead. Also, the first step of such a flight would be difficult to step onto from the front. Enough of the 2nd terrace was uncovered to show that this did not happen. At both the corners of the 2nd "step-terrace outset" with the center outset, the wall was three courses high.

The other alternative requires that one be able to walk along each terrace top to where the next flight of stairs started. This is why the front terraces are equipped with the 25 cm. outset. Going to the top of the first flight one turned 180° and walked along this narrow ledge. The next flight would be so situated that one could get in front of it before starting up. One would not have to climb over the side of the bottom step.

South Stair Inset-Wall Outset

As previously mentioned the stair-inset wall did not stop at the bottom (front) of the stairway but kept going about 46 cm. then inseting 25 cm. to the regular plane of the wall. This outset had been partially covered up on the north step-terrace when the step-terrace was secondarily extended. On the south outset about four courses of this outset were preserved. Exactly what this outset looked like can best be seen in the isometric reconstruction. This outset does not occur on the west side of 37 because it was not needed.

WEST SIDE STEP-TERRACE OUTSETS

Its original extent was clear from the floor that originally turned up to it and to the original bottom step. The two west side step-terraces outlets (one on either side

of the central outset) were the last parts of 37 to be excavated. There was nothing in the profile of the debris to suggest either a stairway or another outset. It was in drawing the plan that the writer noticed that there was something missing. In order to make really sure of the number of outsets and to check further on the possibility of more unique stairways, nearly all the base of the west side of 37 was excavated. The step-terraces' outsets were soon found, but there was no outsetting of the stair-inset wall, nor did it look as if there ever had been.

The preservation of these step-terraces was poor; but it was clear what their original form had been. Parts of the two bottom steps remained on each stairway. Bits of flooring remained on both the bottom steps' treads. Enough of the stair-inset wall was preserved to show that this was identical (except that it did not form an additional outset) to that of the east side step-terraces. The finish masonry of the stair-inset wall never extended very far below the level of the steps. Each step originally would have been from 45 to 55 cm. high, about 80 cm. deep. The stairs varied from 45 to 56 cm. wide. Each stairway would have had four or five steps.

Purpose of the Step-Insets

The exact function of stairways on terraces is not known. They could have been used in place of scaffolding to enable

Mayan workers to keep the pyramids in repair. However, especially in the case of Str.5D-37, the stairways are a major feature of the architecture. By means of the stairways, it would have been possible for people to get onto the terraces to sit and watch parades and the like. Although there might not be much to see from the sides of 73, once onto a terrace, one could walk around to the front and have a good view of whatever was going on in the Great Plaza. Something similar to step-insets may be shown on graffiti (Fig. 3).

Str.5D-72

Immediately to the south of the 1st terrace step-inset on Str.5D-73, is a step-up in the floor level between Str. 5D-72 and -73. This step does not relate to the step-inset of 73 but to renovations of the basal platform of 72.

CONSTRUCTION STAGE 3: BUILDING PLATFORM

The 15.50 m.-high pyramid was topped off by a hard-surfaced mortar floor. It is not known whether the building platform was completely built before the final front stair of the pyramid or not.

Excavation was not extensive enough to determine whether the building platform was the result of one or more distinct building operations. For this paper, however, it will be presumed that it was the result of one operation. It was discovered by excavation that the first pause in building

activity was the laying of a mortar pause layer about 1.20 m. above the pyramid-top floor. This distance puts the layer exactly at the level of the top of the fourth front step and the fourth course of building platform facing masonry--an occurrence of importance. The layer was originally a hard-surfaced, relatively smooth floor. Parts of it were root-pitted, but many areas were still hard. The limits of the floor are not known because of poor preservation and a lack of time to excavate all the floor surface. To the south, the level was followed to within 1.20 m. of the back of the platform; here, excavation stopped. To the north, the floor extended just under the main "step-up"; it may have extended all the way north to the top of a fill-retaining wall (Str. 5D-73: Unit). To the west, the layer may have stopped 1.50 m. short of the west edge of the building platform. The fill at this point was penetrated extensively by roots.

The next pause in building activity was after the 36 cm. (one course) phase. Here, approximately 1.50 m. above the pyramid top, was another layer of light-colored lime mortar. It was far too poorly-preserved to determine if it had ever had a smooth hard surface. The extent of this layer is not known. On this level sat the main step-up of the building platform (Str.5D-73: Unit).

One complication not noticed while recording but observed on looking at the centerline section, was that of an east-west fill-retaining wall, 60 cm. high. The rough mortar layer



Photo 33 Building platform of Str. 5D-73 after partial excavation, viewed from Temple II.



Photo 34 Building platform of Str. 5D-73 with excavation completed, viewed from Temple II.

did not appear to go under the wall (as the wall appeared to be continuous for its 60 cm. height); but the mortar layer ran along both sides of the wall, although on the north side of the wall traces of a mortar layer were noted as being very faint. The front of the fill retaining wall was to the north and was followed west to within 30 cm. of the back of the west side finish masonry (Fig. --).

Upper Level of the Building Platform

Even before excavation, there were clearly visible two levels to the building platform, with the front facing of the higher level still standing. As far as it was preserved, the front facing was excavated (Photo 33). To the west, the facing went close to the west edge of the building platform, showing that the upper level had occupied all the space available to it. The facing was one course high of the same kind of Late Classic masonry used as on the rest of the pyramid. All the stones were laid on edge; stretchers alternated with headers. A typical header was 57 cm. deep and 17 cm. wide; a typical stretcher was 54 x 20 and 32 cm. high. No floor was found intact on top of the level; but fragments of what could have been floor remains were found in spots when the humus was removed. There were no floor turn-ups to any walls, nor was there the slightest evidence of wall stubs or wall debris. On the south, the level was faced by the same wall as the bottom five course high unit. There was no evidence for a

rear outset.

Possible Additional Level Higher Up

There was absolutely no indication that there had ever been another level to the building platform or that there had once been a temple which collapsed and fell over the side. Although the building platform was not completely intact, enough of it was still preserved to determine approximately its original extent.

Possible Additional Level Before Main "Step-up"

A line of partially-disintegrated stones was found running east-west 1.86 m. in front of the main "step-up" mentioned above. The row was 1.30 m. back from the fourth step of the front building platform stair (Fig.19a). The stones were all stretchers, but none were clearly remains of well-cut facing masonry. (Photo 34). Both ends of this wall had been uprooted by falling trees long ago.

As interior levels usually correspond to course levels (about 30 - 35 cm. per course) it is important to establish how many courses (steps) there were to the building platform stairway. If it were known that the stairway was only four steps high, then the wall in question would have had to be a facing masonry wall and would have provided the step-up before the main step-up. If the stairway and the front of the building platform (Str.5D-73: Unit) were five courses high, then

it would have been merely a fill-retaining wall, because there would be no need for another step at its level (see P.105).

Front Fill Retaining Wall

In line with the north front of the building platform and hidden by the stair, was a fill retaining wall joining the facing masonry of the two halves of the front of the building platform (Fig. 19a). This indicates something of the sequence of construction--the front of the lower building platform having been built before the stair was added. Rough stones, requiring less effort to quarry, were used where they were to be covered by the stairway.

Side Inset

2.80 m. from the front of the building platform, the facing wall insets 10 cm. On the west side of the structure this change is still intact.

Facing Masonry

Before excavation, upper courses of facing masonry were visible along the whole north side of the building platform. Later, the roots and accumulated humus were removed making the entire north face visible. The west cornerstone had been uprooted; but the east cornerstone was only slightly pushed out. The wall was in various stages of disintegration up to

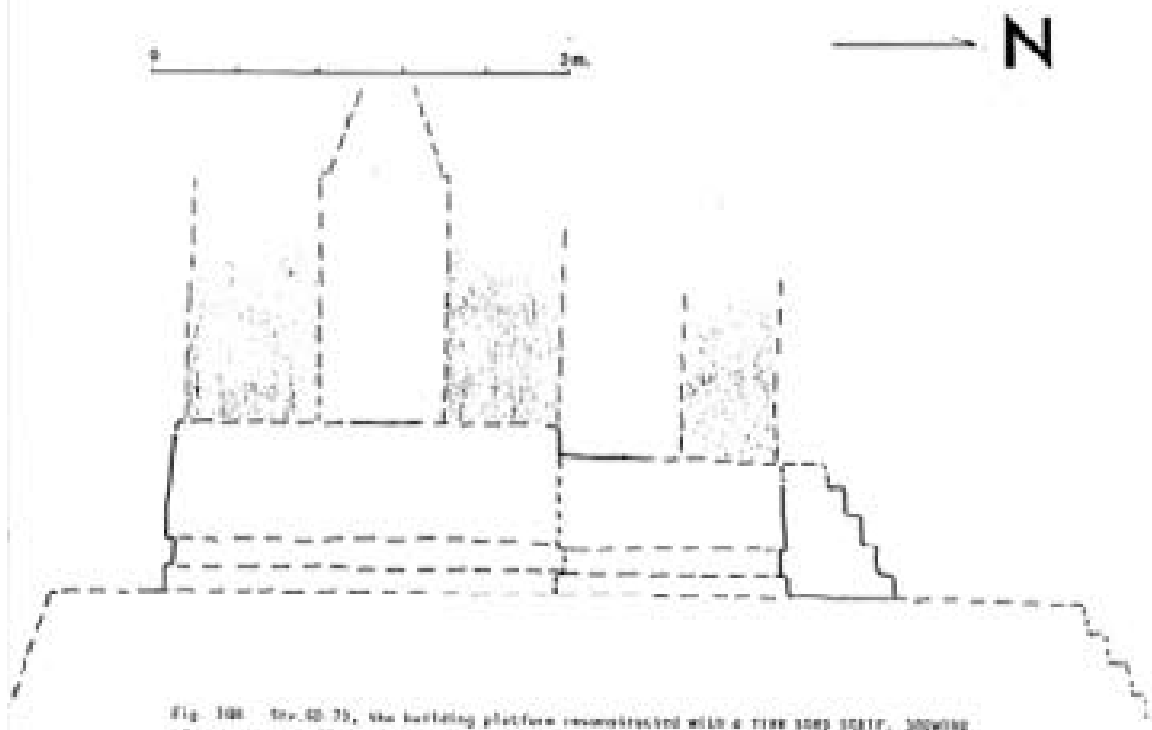

Fig. 140. Str. 52-75, the building platform reconstructed with a 1:100 scale (2017). Showing where masonry walls could have been placed if they were intended.

0 2 m

→ N

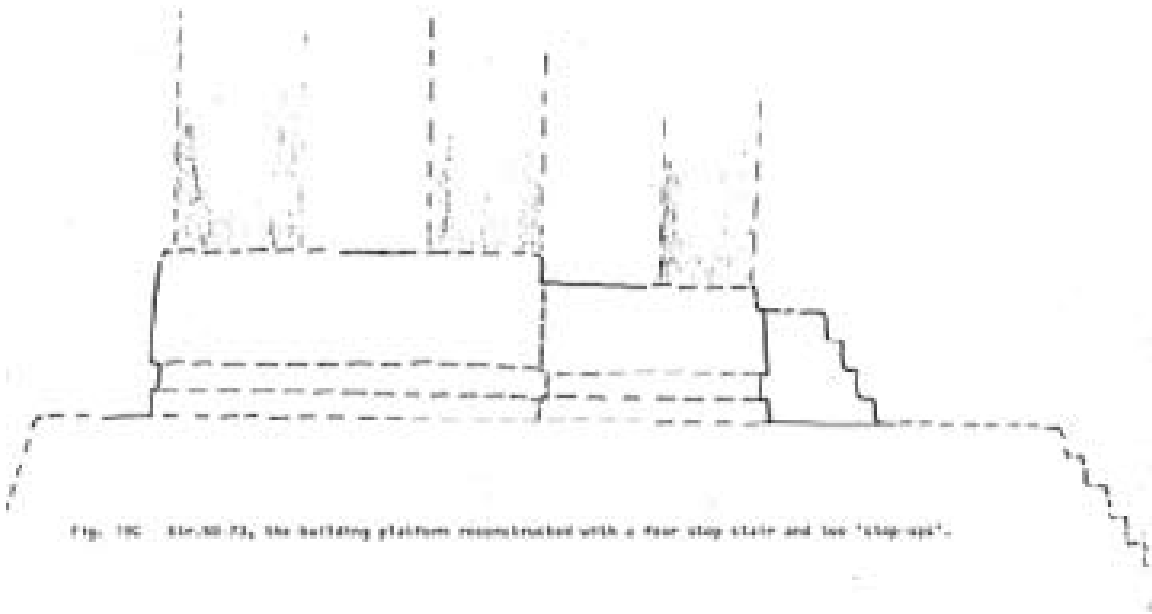

Fig. 10C - 30x30-73, the building platform reconstructed with a rear step-stair and low 'step-up'.

the top of the fourth course. There was absolutely no evidence for the existence of a fifth course or for a corresponding fifth step for the stairway. Possibly, there once existed a fifth course which was uprooted. It is, however, surprising that there would not be even the slightest trace of the course or the fill behind it when in general preservation is relatively good. If there was not a fifth course then the now rough row of stones may have originally been a 'step-up', just as the better preserved one to its south (Fig. 19c).

Artifacts

Not terribly many artifacts were uncovered in digging through the building platform, and no cache material was found (although one incised obsidian, possibly from some cache, was found in fallen construction debris in the tunnel between Strs.5D-72 and -73).

EVIDENCE FOR AND AGAINST THERE EVER HAVING BEEN A TEMPLE BUILDING

There was no floor on top of the building platform that was preserved well enough to hope to find the remains of post holes. Nevertheless, post holes were looked for, and none were found. There was no evidence of a collapsed beam and mortar roof of any large amounts of decayed wood, although

such evidence could easily have been missed. Absolutely no debris was found on top of the building platform, especially no stones which could be attributed to a fallen wall--indeed, no stones at all were lying on the top of the building platform. Nor were any wall stubs found; and the top of the building platform was well enough preserved so that they probably would be visible if they had ever existed.

Thus there are the following possibilities:

1. There was a wooden pole, thatch-roofed temple which completely decayed.

2. There was once a masonry temple, with or without a masonry roof, which was completely removed down to the last stone, perhaps to make room for a new and bigger one which was never started.

3. There never was supposed to be a temple of any kind on top.

4. The pyramid was built right before Tikal was abandoned by its priest-rulers, and there was not time to build the temple.

5. There was once a masonry temple, but all its masonry was removed by Post-Classic people or even later.

6. There was once a masonry structure, but it completely collapsed over the steep sides of the pyramid.

#1 is perfectly possible but seemingly unlikely. In support of it, are the numerous graffiti which appear to represent major pyramids with thatch-roofed wooden temples.

Until the author is able to look at copies of all temple graffiti, he had best leave this question open. Against #1 is the fact that none of the other temples at Tikal of the same variety have wooden temples. Against this last argument and in support of #1, is the fact that masonry temples were not present on 100% of Mayan pyramids; and even when masonry temples were present, they were often thatch-roofed. With a thatched roof, there is no need for the walls to be very thick; but the author believes that the absence of even a fragment of wall debris suggests that there never were walls of even weak, thin, masonry.

#2 is possible but not probable. When new temples were built over old ones, usually at least the stubs of the old temple walls were left.

#3 is extremely doubtful because of the presence of a "building" platform on top of the pyramid and the fact that, architecturally, the pyramid is of the temple variety and was certainly meant to support eventually a temple of some sort.

There is much proof that the pyramid of Str.5D-73 was built while Tikal was still flourishing. There are several floors, including one major Great Plaza floor that abuts the pyramid's facing masonry. Floor-laying did not assume such proportions in Post Classic times. Also, at least one major addition was made to the basal platform of Str.5D-72 after the pyramid for 73 was finished. Thus #4 seems improbable.

#5 is not very possible, because there were more available-



Photo 35 STP.50-73, main stairway, northwest corner of west side-wall.

ble sources for building-stone than the top of 73. Besides, stone robbers would probably not take fill from the wall cores as well and would probably not strip the walls down precisely to floor level.

There was not an abnormal amount of debris on the sides of Str.5D-37, that would suggest remnants of a collapsed temple. It is possible for a whole temple to collapse; but some of the building platform would go with it, and some of the walls toward the center of the building would tend to survive.

Thus, the most plausible answer seems to be that there was, in fact, a wooden building; or, for some unknown reason, they never got around to building a masonry one before the site was abandoned.

CONSTRUCTION STAGE 22 FINAL FRONT STAIRWAY

Much of the final, front, facing masonry stairway and some of the east stair side-wall was visible before excavation; following preliminary clearing of vegetation, even more was visible. The front corners, the entire east stair side-wall down to floor level, and the bottom seven steps on the centerline were excavated. A balustrade was carefully looked for with negative results. Both front corners were partially preserved (Photo 35).

In the centerline trench, the bottom step was still in place, complete with plaster turn-ups to the second step.

Most of the stones of the next two steps were in place (Photo , Fig. 26). Above this, the stones were still in line but were in various stages of disintegration caused by tree roots. Towards the top of the stairway, none of the steps was in perfect place, but many were ripped out in large segments.

Step Masonry

The treads were a narrow 20 cm; the risers measured around 30 cm., and the stairway was 3.37 m. wide at the base, probably tapering slightly as it went up. The stairway stones were similar to those used on the main stairway of 73 and on the main stairs of Temples I, II, and IV--those stair stones being slightly tapered, limestone blocks, finely finished in front and noticeably square-nosed. All the stairways encountered by the author in his East Plaza investigations had definitely-rounded noses. On the 73 stair stones, the non-frontal sides were well-shaped planes, close to being finely finished. The slight taper allows for a stronger mortar bond. The fronts of the stones were beveled to provide the proper batter.

The joints were not broken regularly; each stone was laid horizontally. An average stone was 64 cm. deep, 30 cm. high, and 25 cm. wide (memory). The whole stairway was covered with seemingly non-painted white plaster.

On the east the stair side-wall extended 1.25 m.; on the

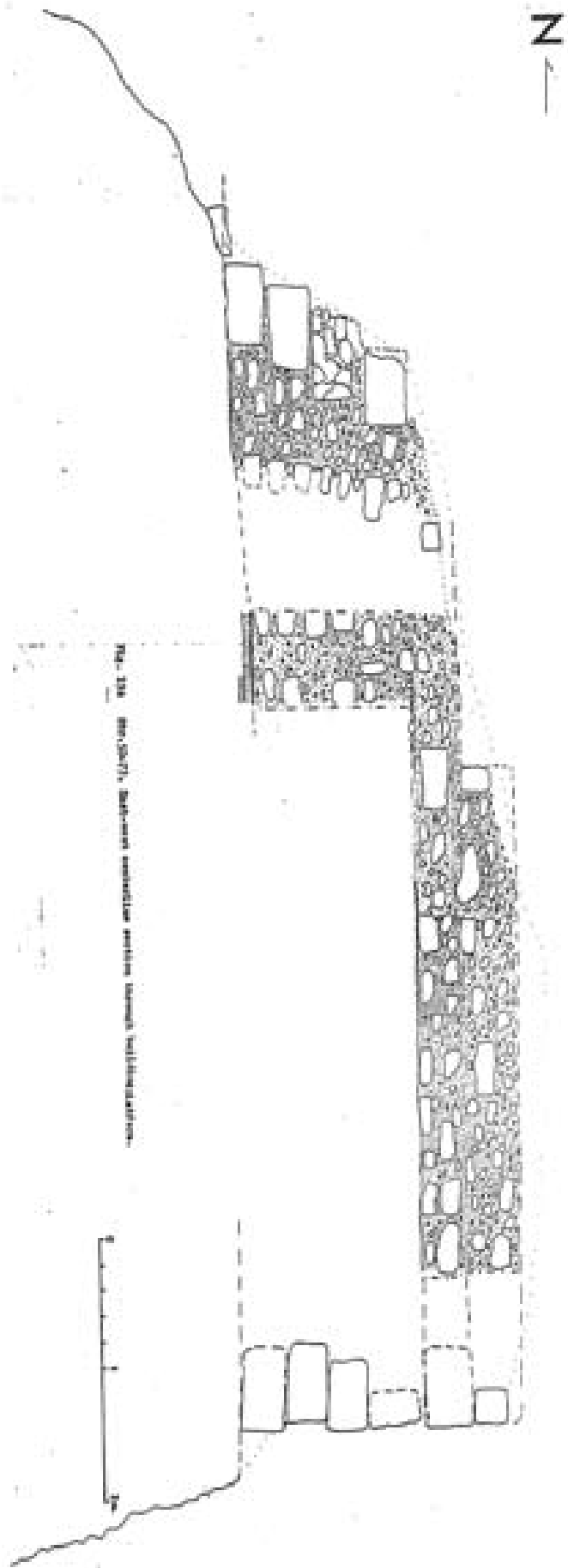

Fig. 126. (189-2077). Sub-surface geological section through hillside.

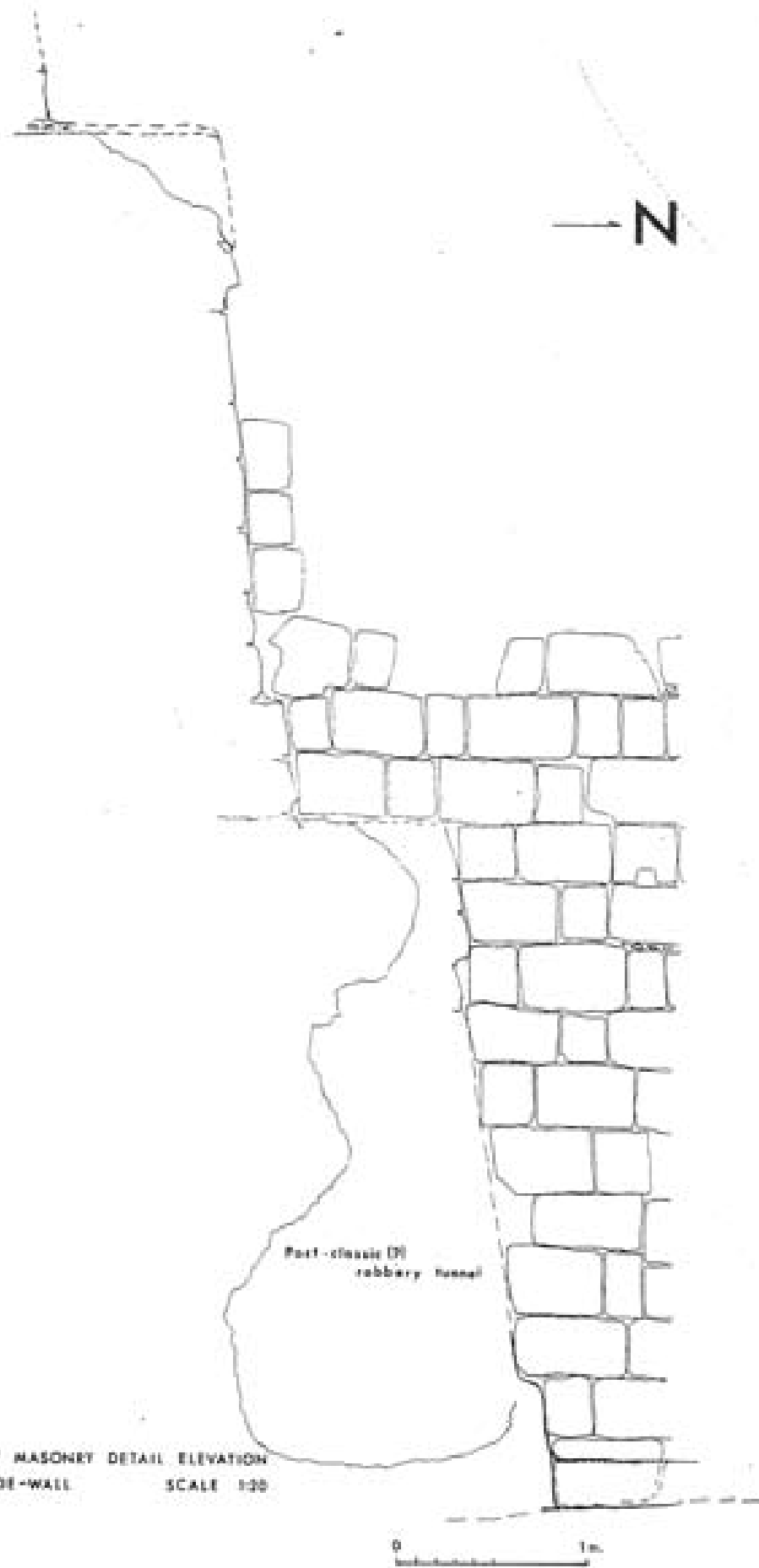

FIG. 20 STR-20-73, EAST MASONRY DETAIL ELEVATION
(EAST) STAIR SIDE-WALL SCALE 1:20

west side it extended 1.10 m.

Stair Side-wall Masonry

The east stair side-wall was completely uncovered for all its extent intact. A part of it was recorded by R. Larios in a masonry detail elevation (Fig. 20). The disturbance caused by the robbery tunnel is visible.

Artifacts

Artifacts between the back of the final stair were cataloged under the number 117A/ 1. Very few sherds were uncovered, and nothing interesting enough to be cataloged by the lab staff was unearthed.

BUILDING PLATFORM STAIRWAY

The position of the construction of this stair in the sequence of construction of the whole pyramid is not known and is given no sequence number. The stair was greatly disturbed by gigantic tree roots, but its width was reconstructed as being 3.45 ± 0.05 m.; it projects 1.25 on the east side, 1.10 on the west side. Each step appears to have been approximately the same height as a course of facing masonry (32 cm.). Only four steps were found. At some point, an additional step or a "step-up" (Str.5D-73: Unit), the uppermost level of the building platform. There was no floor intact at the top of the stairway on any level.

FIG. 21 STR.5D-73, PLAN

FIG. 22A STR.5D-73, FRONT ELEVATION

FIG. 22B STR.5D-73, REAR ELEVATION

FIG. 22C STR.5D-73, EAST ELEVATION

FIG.23 SKETCH PLAN OF BASAL PLATFORM AND LOWEST PYRAMID
TERRACE SHOWING TOMB AND TUNNELS, STR.5D-73

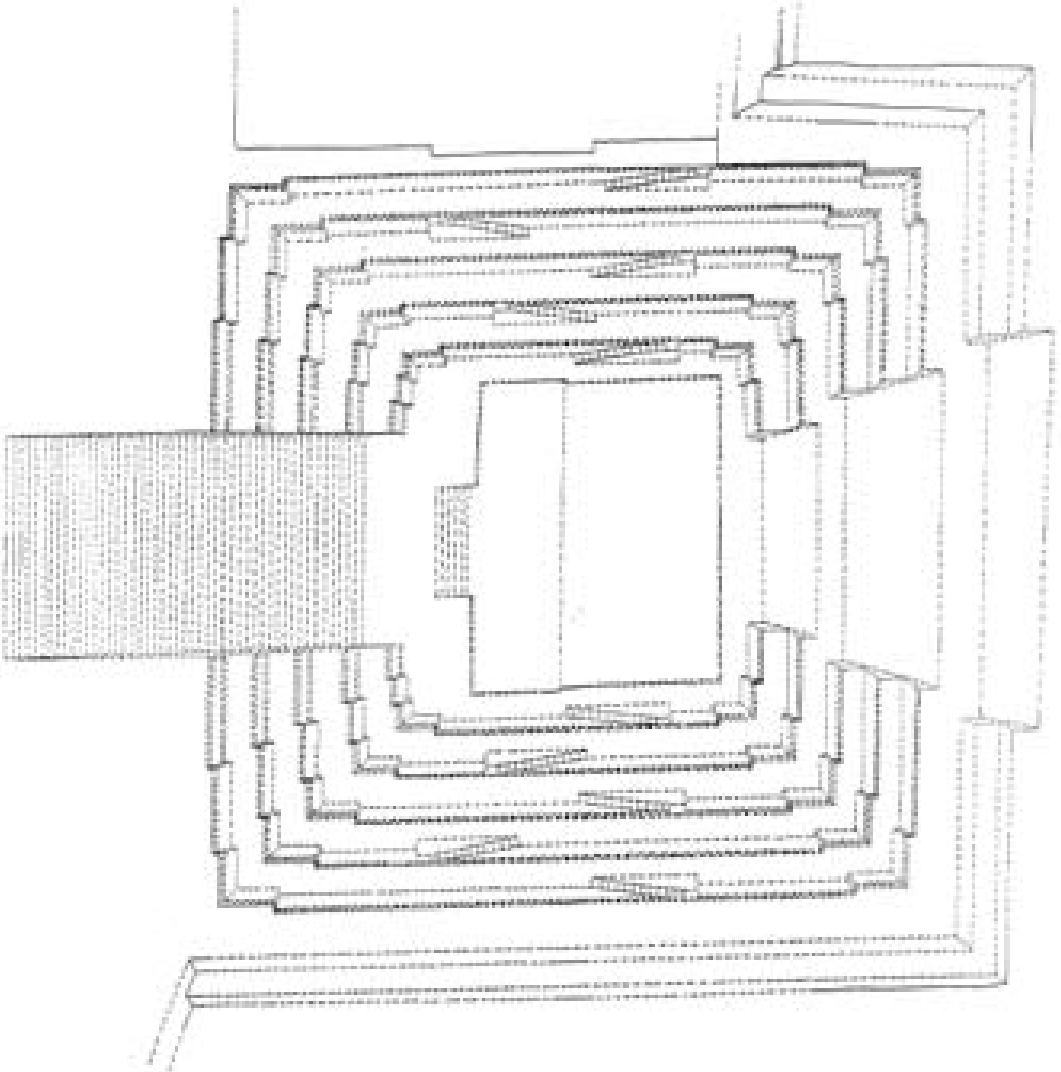

— N

FIG. 21 STR. 5D-73, PLAN



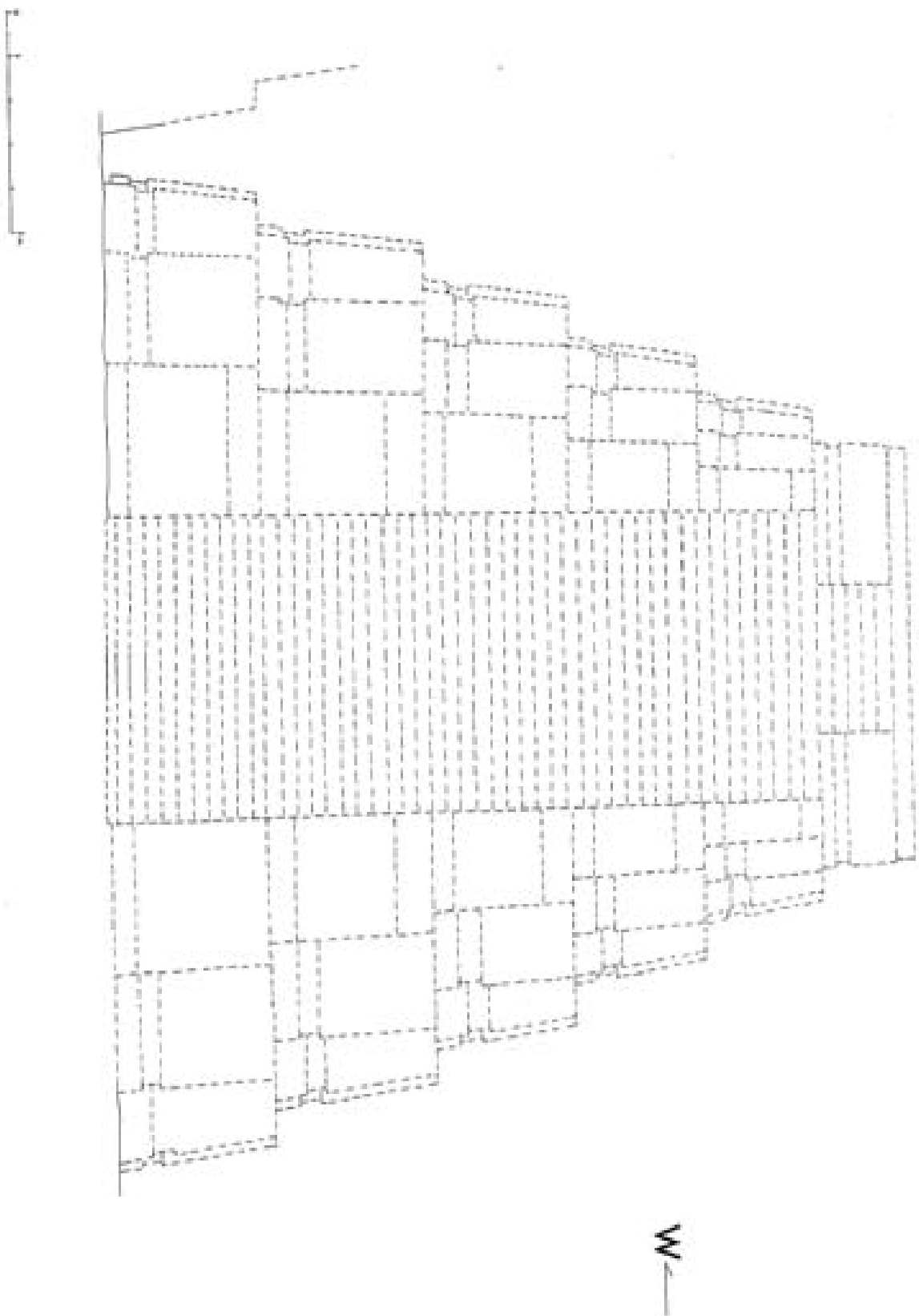

FIG. 22A STR. 5D-73, FRONT ELEVATION

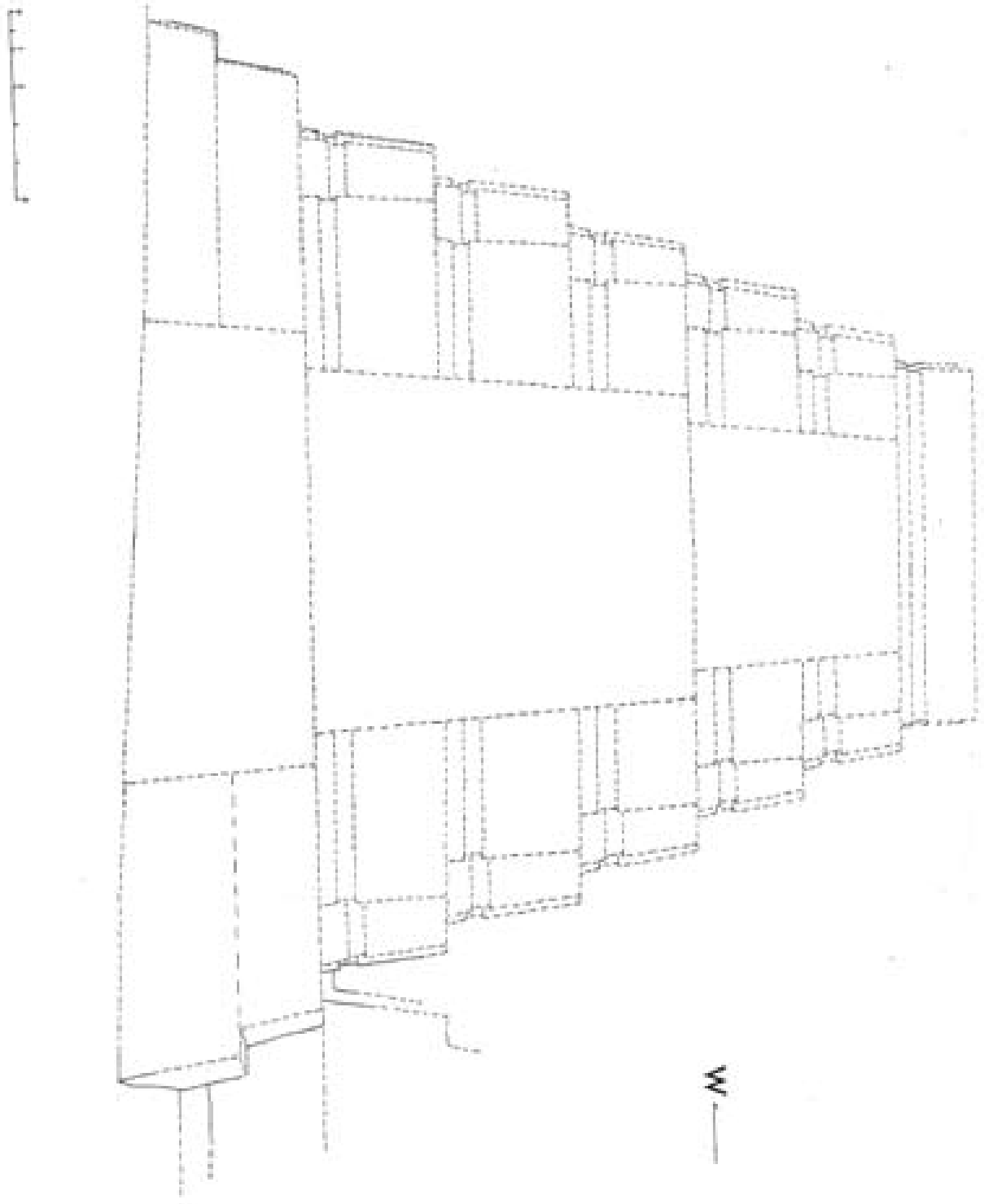

FIG. 22B STR. 5D-73. REAR ELEVATION

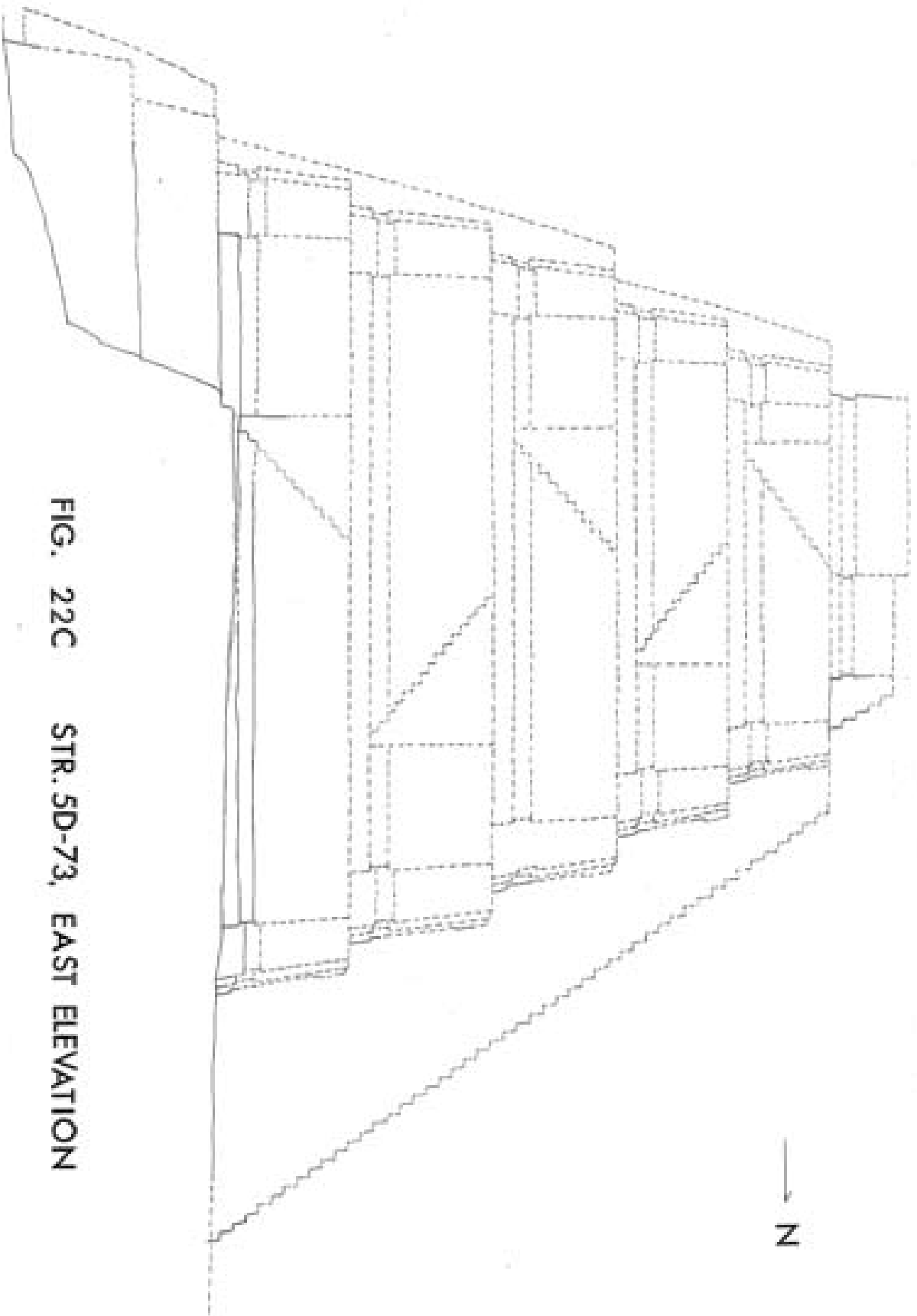

FIG. 22C STR. 5D-73, EAST ELEVATION

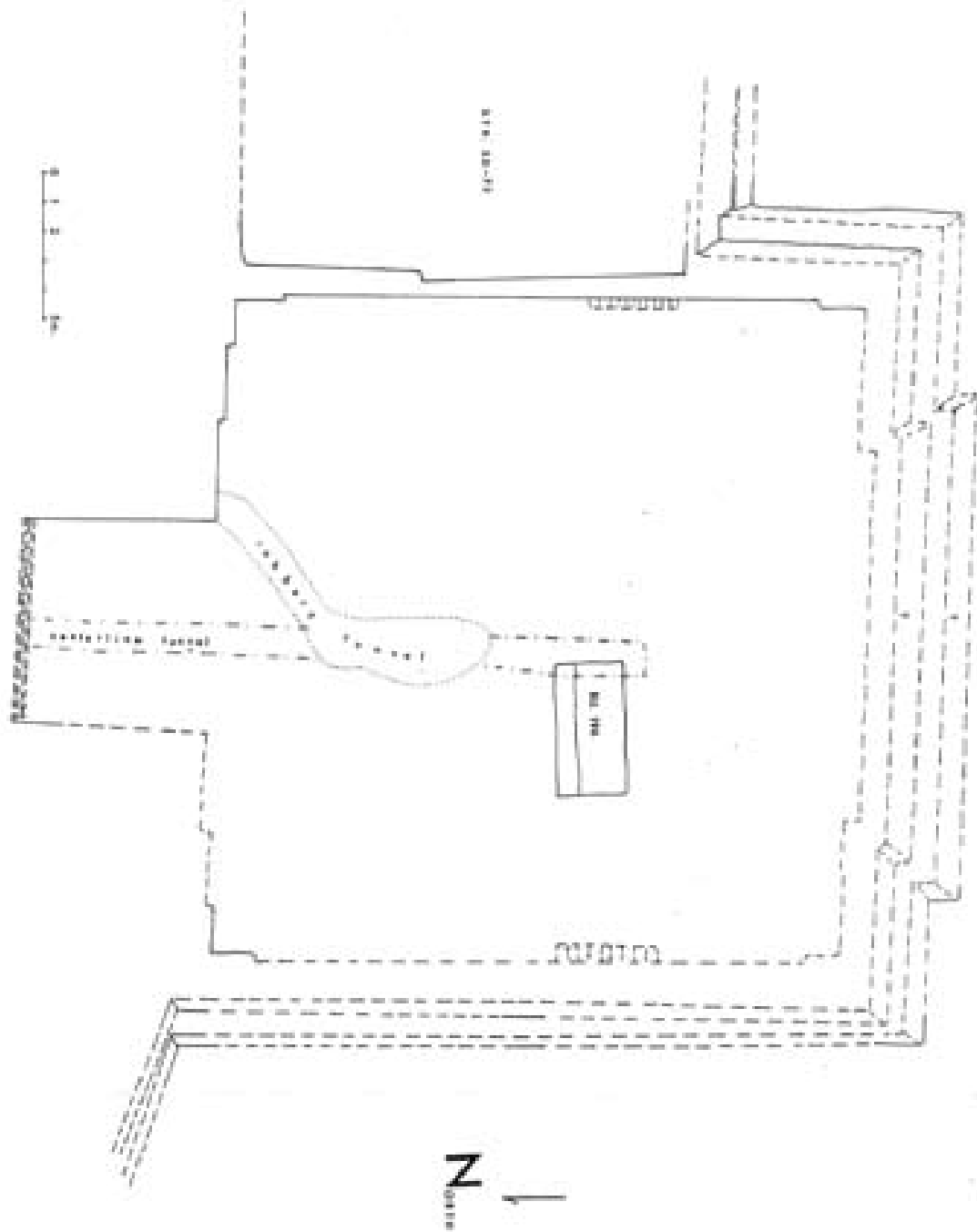



Fig. 20. Longitudinal section of sea water level provided by
 magnetic field sensor.

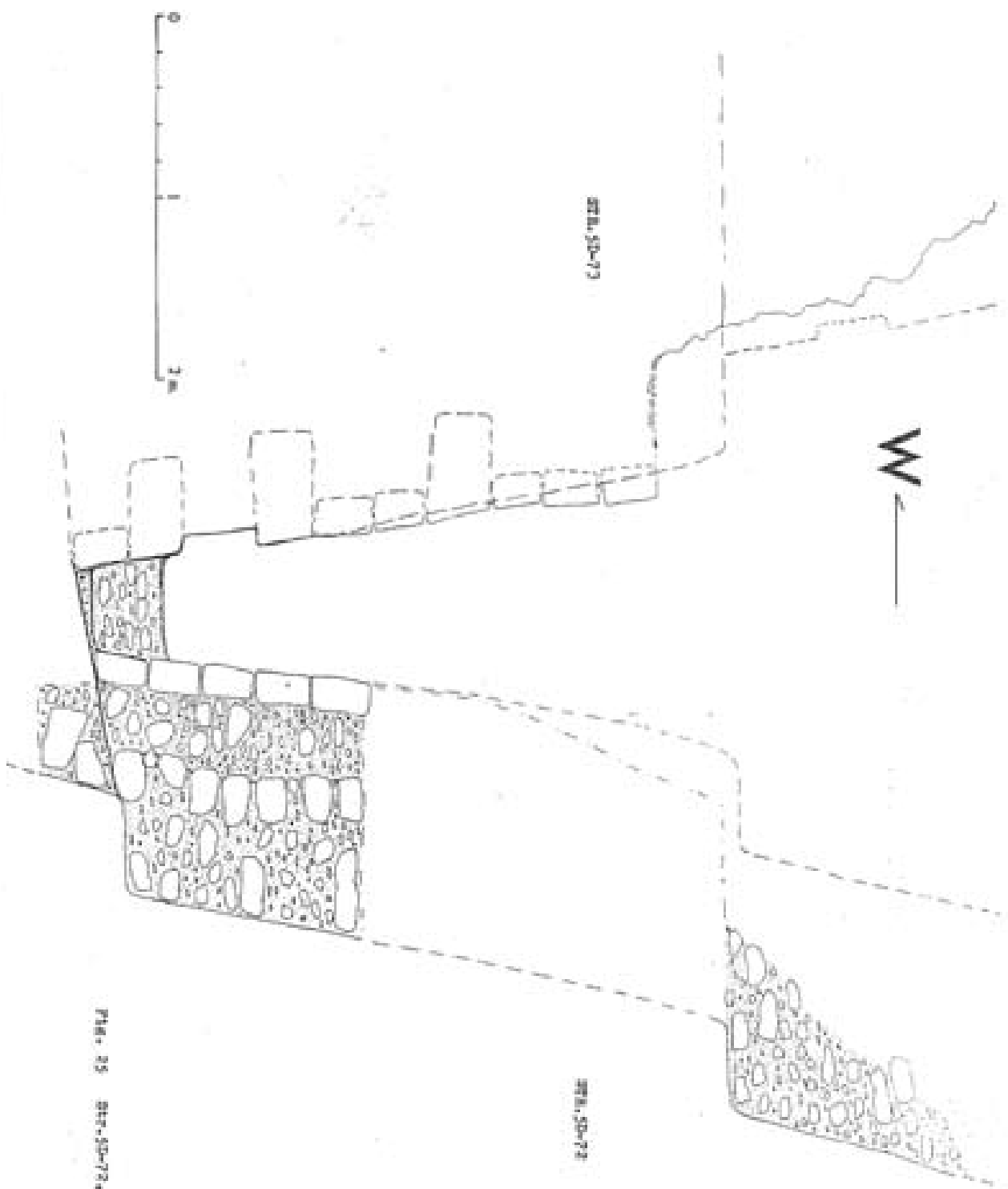

FIG. 25 STB. 50-73, STB. 50-72, south-west section.





The stair was not built until after the front facing for the building platform, as the facing masonry of the building platform ran 30 cm. or so behind the stair and was continued as a fill-retaining wall (Fig. 19a).

Stair Masonry

The step stones were similar to those used on the pyramid stairway, i.e., comprised of slightly tapering blocks laid as headers on their largest surface. All the stones overlap one another without any actual contact. The risers were single blocks.

DIMENSIONS	DEPTH (LENGTH)	HEIGHT	WIDTH
	?	26	26
	?	30	27
	60	27	?

A few stones of the stair side-wall were present, but they were uprooted and partially disintegrated.

CONSTRUCTIONAL ACTIVITY AFTER THE PYRAMID WAS FINISHED

After Str.5D-73's pyramid was finished constructional activity continued in the vicinity. This helps to narrow the dates possible for 73 because no major floors were laid in the Great Plaza area in Post-Classic times; consequently Str.5D-73 is not immediately Post-Classic. Not only in the Great Plaza, but also in the low area behind 73, floors continued to be laid, here abutting the basal platform of 73.

Plaza Floors

After the pyramid of Str.5D-73 was completed a floor was laid abutting it. Also, there seems to have been an additional floor in the narrow space between Str.5D-73 and Str.5D-72.

On the back and sides of the Str.5D-73 several floors were laid which abutted the 73 basal platform.

STR.5D-73: TIME-SPAN 1 - THE ROBBERY TUNNEL

Approximately 11 m. into the pyramid, in the centerline tunnel (Fig. 26) a large cavity was discovered (Photo 36). It extended back into the pyramid 5 m. from where first seen, and to the west it looked as though it may have gone northeast. At first, the author thought he had found a tomb, and one big enough for a whole dynasty. The centerline tunnel was widened to permit entrance into the chamber, and the content of the chamber fill could be seen--it was silt covered by up to 40 cm. of bat droppings. The chamber was carefully cleaned by layer, and artifacts were collected accordingly. The chamber appeared to have been approximately 1.60 m. tall and a maximum of 3.25 m. wide and was right on the centerline. The ancient robbers had cut below the floor about 40 cm. and had apparently stopped. The "floor" of their cut had a trampled-down mud appearance. It is not entirely certain that this level was as far down as they went. A trench was sunk through the level, and no large fill stones were encountered, although it appears that the fill of the Great



Photo 36 Str. 5D-73, centerline tunnel with robbery cut as first seen.





Photo 37 Robbery chamber before excavation.

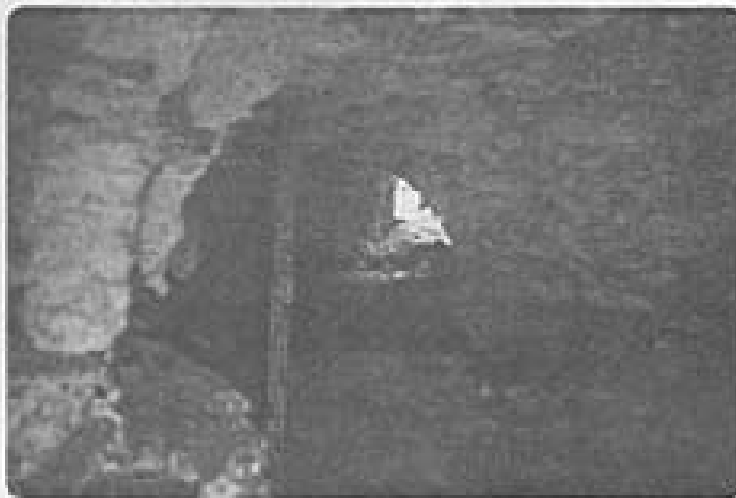

Photo 38 Str. 50-93, robbery tunnel looking from the centerline to the outside, after removal of accumulated debris.

Plaza at this point had no large fill stones (Seen on the side of the tomb cut further south, see p. 28).

When the chamber was cleared out, it was apparent that there had been a tunnel to the outside (Photo 38). This tunnel was completely choked with silt which made it at first invisible on the outside. When the tunnel was cleared, the method of entrance was visible. Rather than starting on the centerline, as did the excavator, the robbers knew that the easiest and shortest way to reach the centerline was by beginning at the intersection of wall, at the 1st terrace level (Fig. 23). For some reason, they did not start exactly at floor level, but about 40 cm. above it, suggesting that the pyramid had partially collapsed or that there was debris of some sort in the interior corner. They dug a tunnel about 1 m. in, 1.20 m. high to a point at which they began to dig down, 60 cm. in a short space; then the tunnel leveled out at just about floor level. Interestingly, at this point they did not seem to have actually reached the floor. 5.60 m. in the floor was uncovered and 40 cm. on was cut through to a depth of about 60 cm. The floor was not cut through until the tunnel reached the centerline of the pyramid.

The fill above the tunnel and chamber had hardly collapsed at all but was eroded (by air, water, ?). The only thing possibly associated with the robbery cut was a patch of burnt floor on the plaza floor just in front of the en-

trance to the cut. This may merely be coincidental. There were no tools or other artifacts obviously belonging to Post-Classic peoples.

Artifacts

Many of the sherds in the silt and bat droppings were either fallen from the roof or washed in from the collapsed fl11 at the entrance 117A/5, part of 4, 8, 10, and 11 were all taken from the lower levels of silt in the "chamber". These were the levels which would contain artifacts possibly left by the robbers. The following artifacts were cataloged:

OP 117A	QUAN-	SUBSTANCE	OBJECT	DIMENSIONS
LOT	TITY			
10	1	Bone	Animal, unmodified rodent tooth fragment.	
11	1	Shell	Local land snail (Dxystyla princeps) unmodified.	
11	1	Stone	Unmodified, small fragment of stalagtite. L. 3 cm.	
11	1	Flint	Flake-blade, L. 4.1 cm.	
11	1	Flint	Flake-blade, used ? Dark grey, flat, no visible bulb, possibly used on one edge, 5.4 x 3.4 cm.	
11	1	Flint	Core fragment, used 3 x 2.6 x 1.4 cm. grey.	
11	3	Flint	Two unmod. flakes and one unmod. core frag. Flakes: grey, no bulb, 3 x 4.5 cm. brown, no bulb, some cortex, 2 x 3. Core frag.: pink, 3.5 x 4 x 2 cm., some cortex.	
11	1	Obsidian	Flake-blade, retouched, L (3.5) cm	

None of the sherds or artifacts from any of the other levels of silt were cataloged.

Who Dug the Tunnel

From the artifacts there is no hint as to who dug the tunnel. From the method of excavation, however, there is a hint. Whoever dug the tunnel seems to have known that offerings would be on the centerline and that the quickest way to the centerline was not through the front stairway, here, there might be caches but no burials.

There are several other well-recorded robbery attempts, especially in North Acropolis temples, but the author does not have detailed information on these for comparison. Jade seems to have been what the robbers were after, but they usually left some artifactual remains and usually sealed their passages. The tunnel into Str.5D-73 was not sealed or filled-in.

There is a possibility that Mendez may have been the one to have dug here; but, by the time he arrived at Tikal, the pyramid had probably decayed to its present extent, and a tunnel would have to start off higher up than it did.

FIG. 26 STR.5D-73, NORTH-SOUTH CENTERLINE SECTION

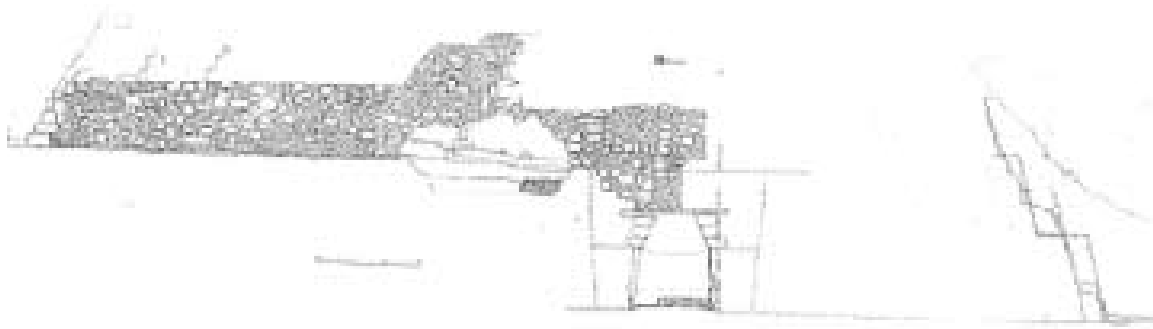
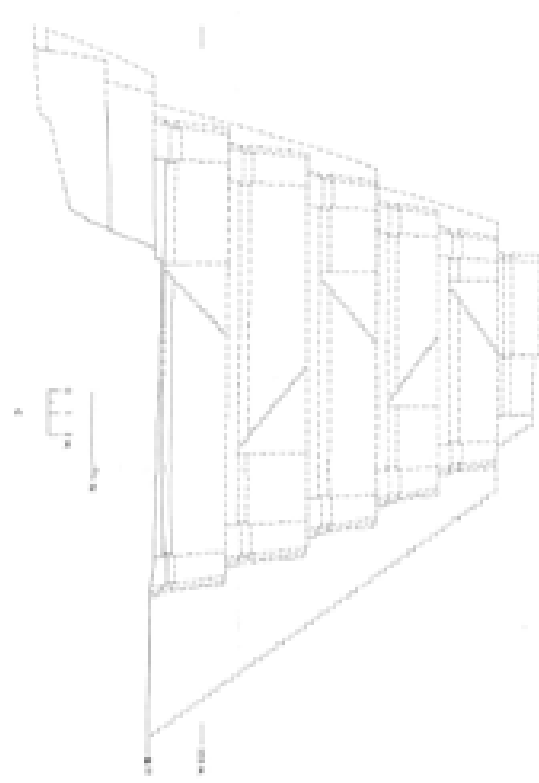
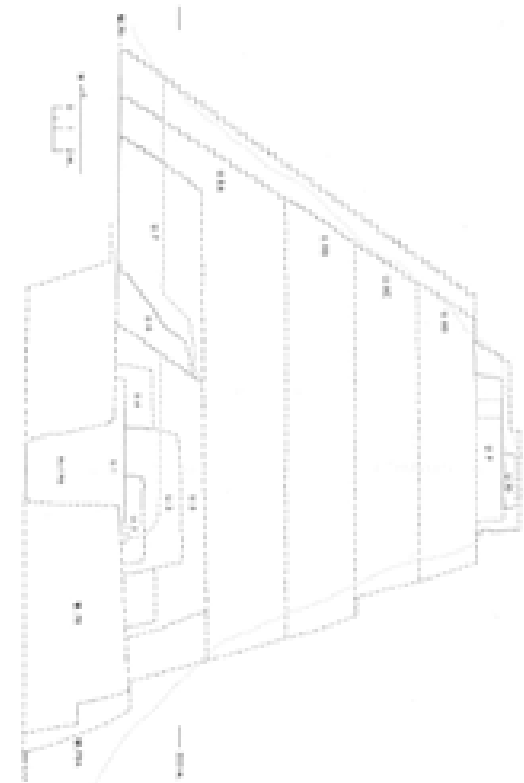
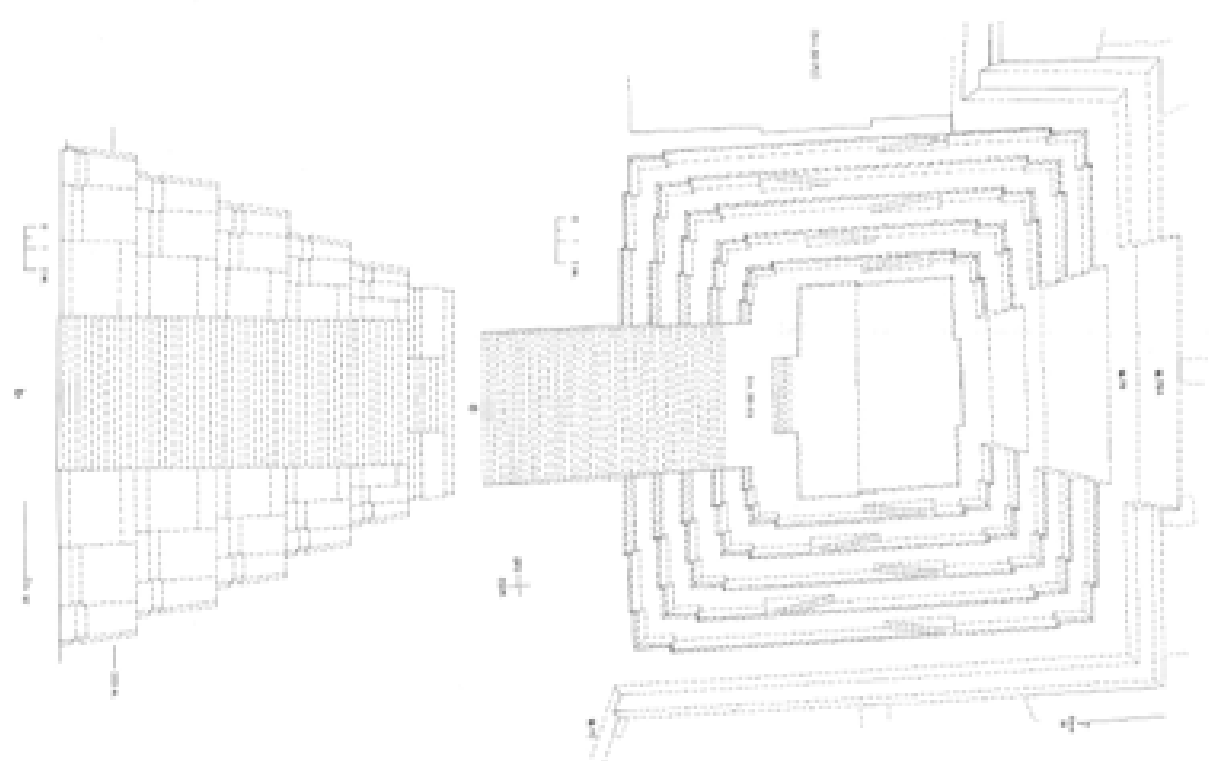
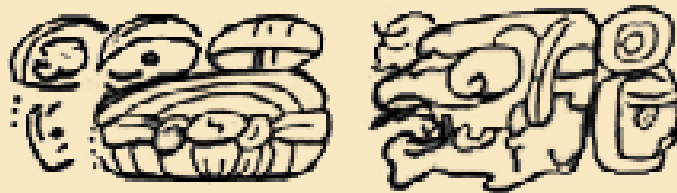

FIG. 10. SECTION THROUGH THE GATEWAY





STRUCTURE 5D-73, BURIAL 196,
TIKAL, PETEN, GUATEMALA

A PRELIMINARY REPORT

by

Nicholas Matthew Hellmuth

Submitted to the Department of Anthropology
in partial fulfillment of the requirements
for the degree of Bachelor of Arts with Honors

Harvard College
March 31, 1967

Volume 2

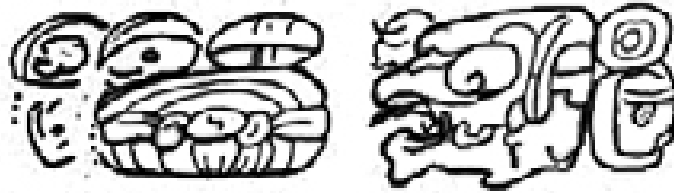

STRUCTURE 5D-73, BURIAL 196,
TIKAL, PETEN, GUATEMALA

A PRELIMINARY REPORT

by

Nicholas Matthew Hellmuth

Submitted to the Department of Anthropology
in partial fulfillment of the requirements
for the degree of Bachelor of Arts with Honors

Harvard College
March 31, 1967

Volume 2

published and distributed by the
Foundation for Latin American Anthropological Research
Rollins Campus Box 2675, Winter Park, FL 32789

edition limited to 50 copies
of which this is copy

INTRODUCTION

Because burials had been found in the majority of large temple-pyramids at Tikal, it was thought from the beginning that a burial could be found within Str.5D-73. Unfortunately, the writer had no experience in searching for tombs, and, in fact, had seen only one other burial in his life.

EXCAVATIONS

Method of Excavation

From observations at Tikal, it was obvious to the author that the way to find the burial was to dig a tunnel on the centerline. Therefore, to establish the center of the structure, the front (north) corners of the front stairway were excavated (Photo 35). Since the front stairway is centrally located, the center of the stairway is the approximate center of the pyramid front. Consequently, with both corners of the stair cleared, the author measured the width of the stair, divided this measurement by two to find the center and started the tunnel. The more orthodox procedure is first to draw up an accurate plan of the base of the structure to determine not only the exact centerline but also the correct angle the tunnel should make with the rest of the base. This is necessary to keep the tunnel from drifting off the centerline. There was not enough time to first draw up a plan, so the author kept the tunnel lined up by eye and by a system of

strings and stakes at a right angle to the front of the stair. At any rate, the makeshift system worked, because the tunnel ran straight to the tomb (check Fig. 23 for plan of the tomb).

Two workmen, experienced in tunnel excavation as well as in general digging, handled the actual physical labor of pick and shovel work. The tunnel was wide enough for a large wheelbarrow and was a little higher than usual to allow for the author's six foot stature. The workmen could progress at the rate of approximately 1 m. a day. At no time was there ever any danger of the tunnel collapsing, as the fill through which it cut was solid.

The tunnel was dug at the level of the Great Plaza floor on which Str.5D-73 rested. This is the normal level to start with and the best way to dig because the tomb-cut in the floor can easily be seen. The tunnel was dug straight back, with time taken to record the masons' stairs as they were uncovered. After several weeks' work the "robbery chamber" was encountered (see p. 107), and tunneling was halted until this feature was recorded. Then, on the south end of the robbery chamber, the floor was once again picked up, and excavation proceeded about 70 cm. to where a cut in the floor was found with a fill retaining wall behind it (Fig. 26, Photo 29). The cut in the floor indicated that there was almost certainly a tomb a little further south and several meters down.

Offerings of Flint

Lying over the floor in a trampled-down layer of mortar were five flint chips (Photo 29). This meant that there was a large tomb below as flint chips have been found over several of the major Late Classic tombs at Tikal, notably in Temple I and at Uaxactun (see p. 61). As excavation proceeded southward and down, the number of flints increased until hundreds were coming from the fill. The flints, along with some obsidians, had not haphazardly been pitched into the fill but had been carefully placed there.

Finding the Tomb

After the cut in the floor had been found, the author wished to keep digging horizontally to the south in an attempt to pick up the south edge of the tomb cut. After digging another two meters the author realized there was not time to do this, and, believing that the tomb lay more or less straight down from where the excavation had thus far reached, began digging down. Soon the workman's pick went through into a void and the tomb had been found.

The tomb could not have been entered at a better place, even if the author had known its location beforehand. If the tunnel had been just a little further to the west, the workmen might have fallen right through the roof and caused extensive collapse. If the tunnel had been to the east the



a) front stair



b) 1st masons' stair



c) 2nd masons' stair

Photo 39



d) robbery chamber after excavation



e) tomb cut (barely visible)
and fill retaining wall

tomb would have been missed altogether on this first try.

It is difficult to describe one's emotions when something of the nature of a large tomb is found. The first hole the workmen made in the tomb's side was fist sized and allowed one to peak at what lay below. The first thing to ascertain was the extent of collapse and then the size of the burial chamber. Soon the opening was enlarged to allow one's head to enter and later so that one could squeeze into the burial chamber.

A good summary of the sequence of discoveries within the tunnel may easily be seen in the series of photographs opposite P. 114. The first job after the centerline was established was to cut through the front stairway (a); shortly thereafter, the 1st masons' stair was found (b); then, the 2nd (c); several meters further, the partially filled-in robbery chamber was reached (d); after the chamber (e) was cleaned up (f), the tunnel was continued for about 70 cm. where flint chips were found in front of a fill-retaining wall (g); the tomb cut was in the floor just in front of the wall; digging down and further south the tomb chamber was soon found (h); after clearing an entrance hole in the east vault the inside of the tomb was visible (1).

Excavation of the Burial Chamber

When first found (Photos 12 and 13), the tomb contained not a single visible offering, as the entire floor area was

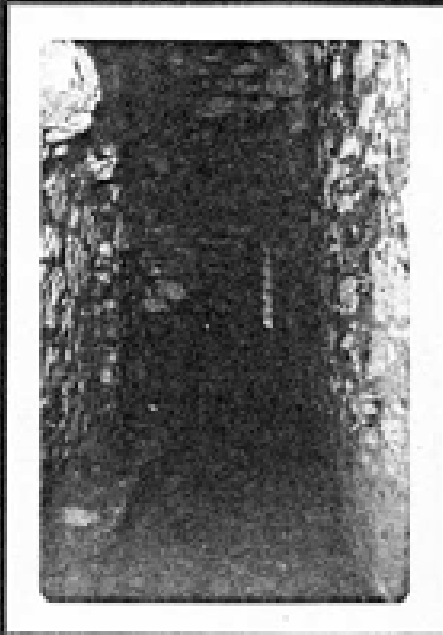

d) centerline tunnel

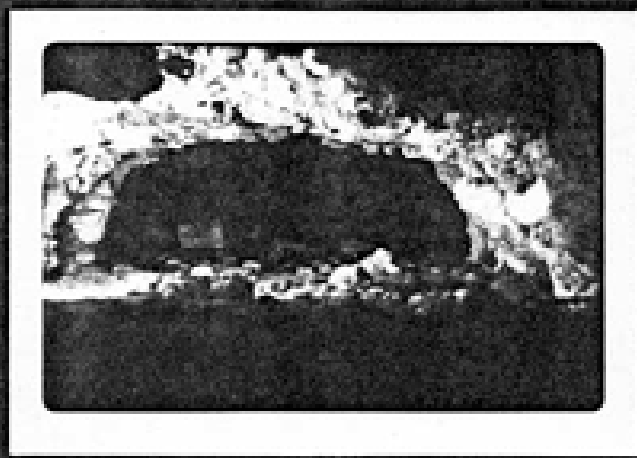

e) robbery chamber

Photo 39

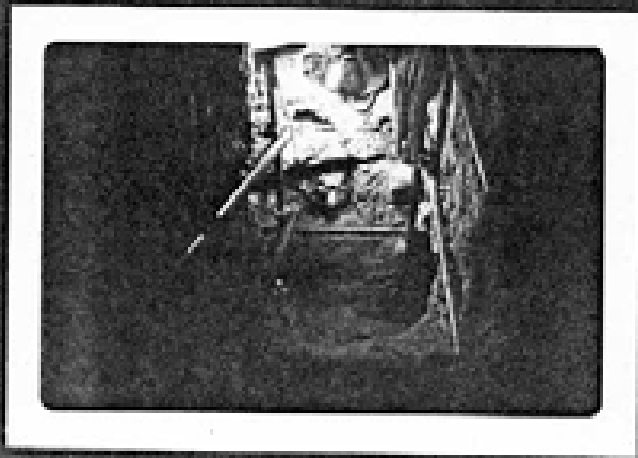

h) entrance to tomb

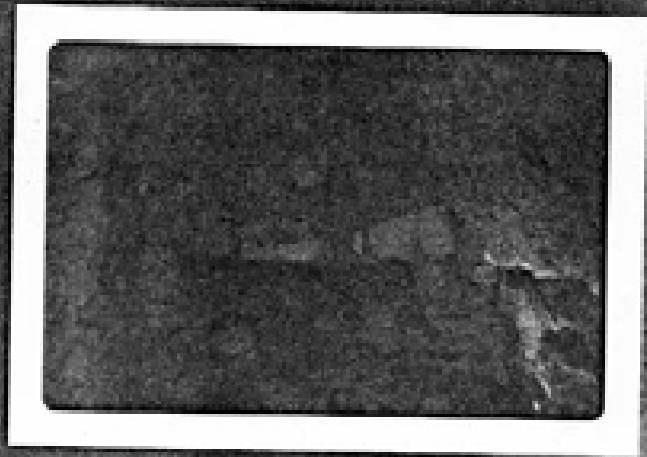

i) the tomb

covered with about 30 cm. or more of collapsed wall and roof debris. Never having excavated a tomb before, much less a simple burial or even a cache or problematical deposit, and with most of the staff on vacation, the writer was not able to be guided by standard excavation technique. From reading reports it seemed that the standard method of excavating a burial was to begin in one corner and work outwards, leaving all objects in position until every scrap of extraneous dirt was removed. At this point an excellent photograph could be taken and a plan made. This, however, presents the problem of moving around inside the tomb, especially to take photographs. Even without visitors, some delicate object is bound to get stepped on and smashed. So, the author's first step was to install a novel system of scaffolding to eliminate all the problems of the standard method.

In each of the four corners of the tomb the author very carefully excavated to the floor level. From looking at the plan of Bu. 116, it appeared that there was little chance of there being any offerings in the corners. In each corner an upright scaffolding pole was placed on a wooden block (to protect the soft floor). Next, strengthening cross-pieces were placed horizontally at three levels: right above the debris, about 1 m. up, and just under the roof. The roof level members were used to support a "ceiling" of strong wooden 2 x 6's to protect both the excavator and the excavated. This made it virtually impossible for a major collapse of the

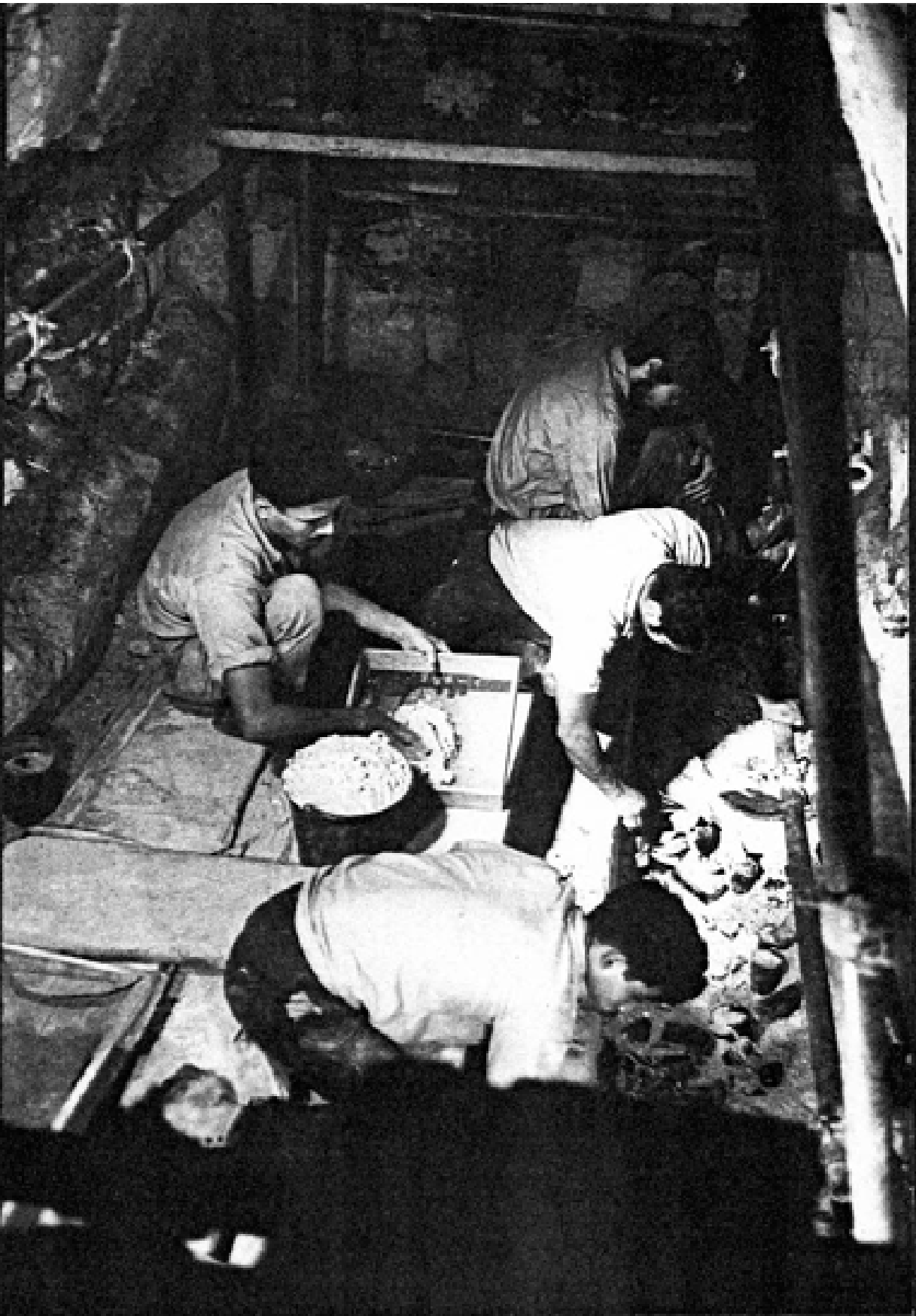

Photo 40 The writer and workmen excavating from the scaffolding.

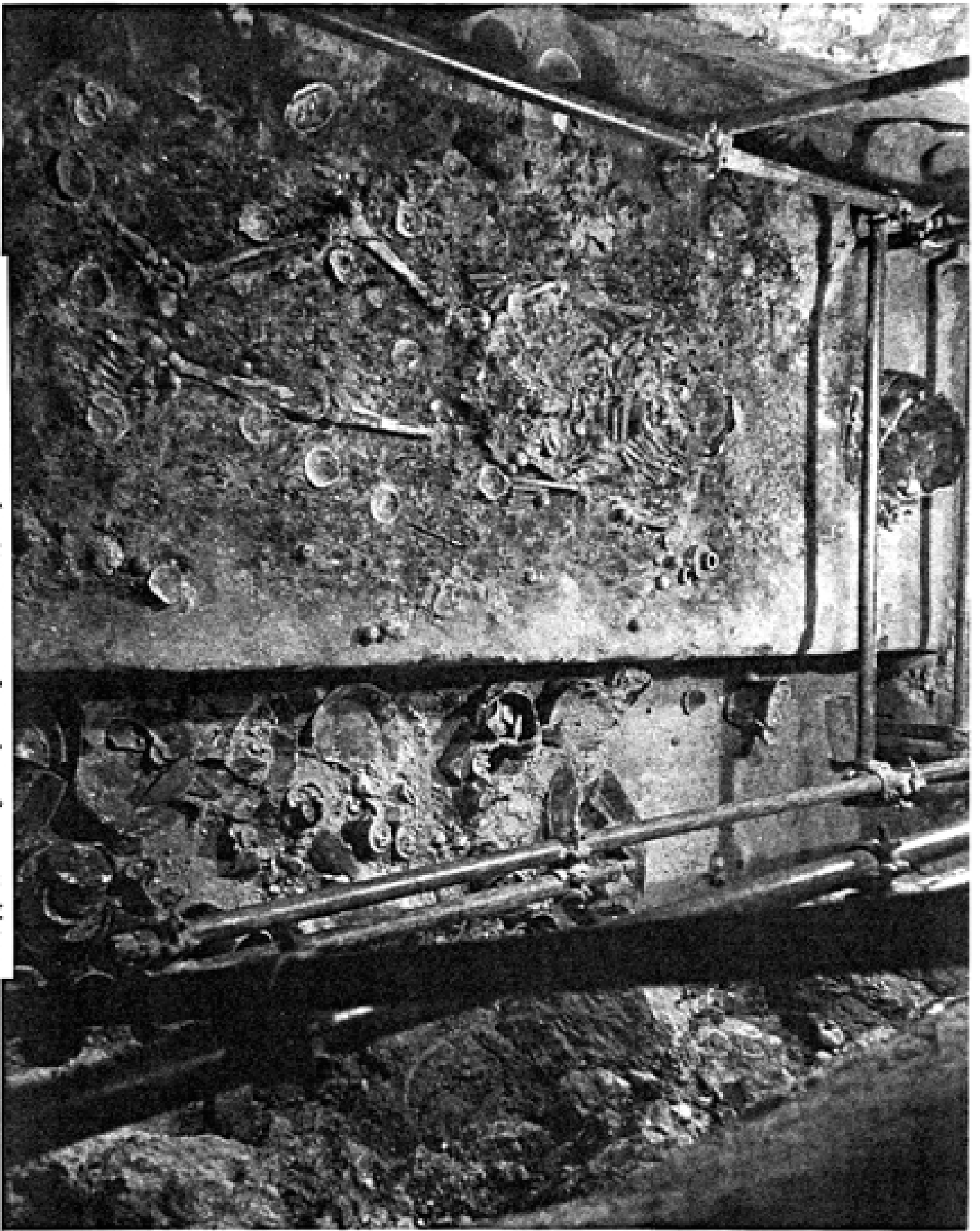

Photo 42 Bu. 196 after several weeks of excavation.





Photo 43 Bu. 116, Temple I (Tikal Project photograph)

tomb to occur while work was in progress.

At "floor" level it was then possible to put planks across either lengthwise or widthwise. This enabled from one up to four people to be at work inside the tomb (Photos 41, 42), without any need for walking on top of the delicate offerings. As the debris was removed from over the artifacts it was quite easy to move the whole platform down so that it was eventually almost on top of the body of the priest. The excavator usually excavated in a kneeling or prone position, using pillows to lessen the hardness of the wooden planks.

When overhead photographs were desired, the writer merely had the platform moved up to the wall-top level cross-pieces and photographed straight down. The use of scaffolding and a wooden floor also enabled important visitors to actually enter the tomb.

The tunnel had to be excavated by light from a gas lantern, which made it difficult to see and especially difficult to take photographs. In excavating the delicate artifacts within the tomb no facility was too good; so, after being frustrated by a low output generator, a large, efficient gas powered generator was put in the Great Plaza by the author. A long cable was used to bring electricity both to Bu. 196, and to Bu. 195 in Str.5D-32 across the Great Plaza on the North Acropolis. This new generator was powerful enough to support two blue photo-floodlights necessary

for color shots. For day to day excavation, two 150 watt bulbs were used in the tomb with a few less powerful bulbs in the tunnel.

For removing the larger rocks, the native Guatemalan workmen were found to be very efficient. They had much more patience than did the author and could peck away at one spot for hours on end without moving. When the actual offerings were reached, native workmen only removed debris from around the sturdy vessels in the aisle. All the cleaning of the material on the bench and the final clearing of the aisle was done by the writer, with one workman to sift. Dirt and debris from close to the offerings, as well as collapsed debris further up was all sifted before it was removed from the burial chamber.

It took about four weeks to dig the tunnel to the tomb, about ten days to remove the large fallen stones, and then over five weeks to clean and record the artifacts in situ. After the largest stones were removed, all work was done with one-inch soft brushes until the offerings were reached. Then, even smaller brushes were used. The author found that the little squeeze blowers meant to blow dust off a camera lens were often very useful, especially to clean around jade.

Operation Number

The material from the tomb was cataloged under 117A/36.

Location

The floor of Bu. 196 was located 4 m. below the Great Plaza floor on which Str.5D-73 was built. The tomb's axis is east-west (Str.5D-73 faces north). The burial's occupant's head was to the west. The tomb was approximately on the centerline of the pyramid (Fig. 23).

GRAVE

The tomb chamber had been specially prepared. The chamber was below "ground level" and was rectangular in ground plan. Its base dimensions were 2.30 m. north-south, 4.50 m. east-west. There was a 30 cm. high rectangular bench against the whole length of the south wall. This left an aisle 75 cm. wide running the length of the tomb on the north side. This arrangement was very similar to that in Bu. 116, Temple I (Compare Photo 42 with Photo 43).

INDIVIDUALS AND ASSOCIATED MATERIALS

INDIVIDUALS

Arrayed on the surface of the bench was the complete skeleton of a single, adult male lying supine, head to the west, with the face upwards. The face had been badly smashed by the collapsing walls and ceiling, and the teeth were in particular disorder. The eye sockets were partially hidden by pieces of a headband of jade disks. Both arms

were extended with the hands placed over the thigh; the author was unable to determine whether the hands were palm up or not. The right leg was extended and very straight compared to the legs of the Bu. 116 skeleton while the right foot was curiously bent. This was possibly the result of the foot's having been hit by falling stones but may have some other meaning. The left leg was out of position seemingly as the result of having been hit by falling stones. Many of the bones were remarkably well preserved considering the weight of the burden above them.

The author was not experienced enough to be able to determine the age of the deceased. Various tourist doctors stated that the bones were those of someone over 20 and under 50 years of age. Bill Haviland, the Tikal Projects' physical anthropologist, has not yet studied the remains.

This was a primary burial with the body probably having been placed in the tomb while still in the flesh. Besides the articulated position of the bones, this conclusion may be inferred by the presence and position of elements of clothing and body ornaments.

ASSOCIATED MATERIALS: WITHIN GRAVE

Acknowledgements

Virginia Greene cataloged and made the drawings of almost all the artifacts within the tomb. Her technical descriptions of each artifact, measurement and color, are used

FIG. 27 Plan of Bu. 196 showing the offerings.

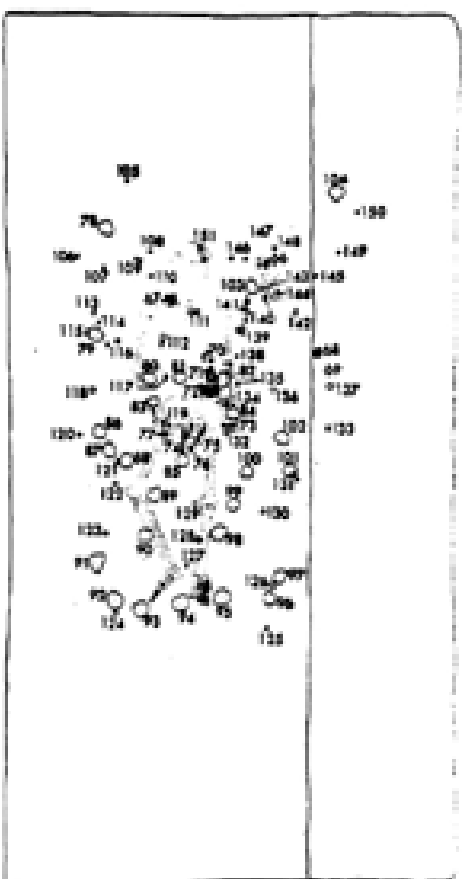
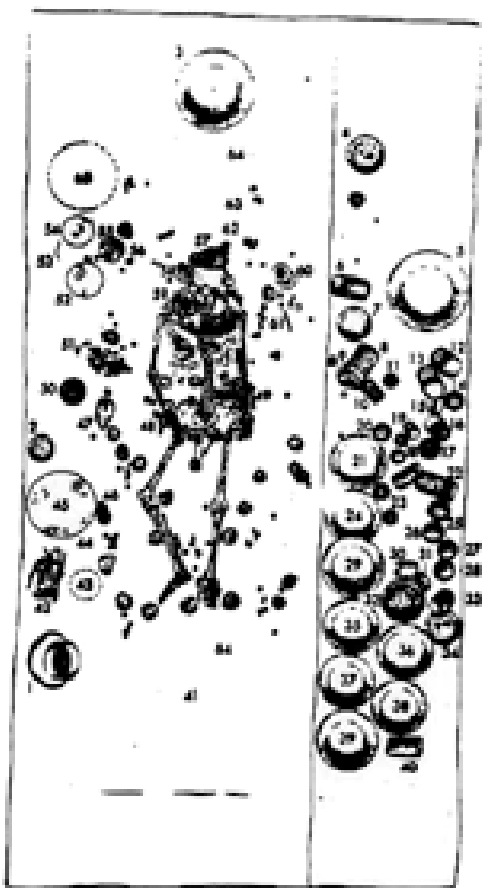

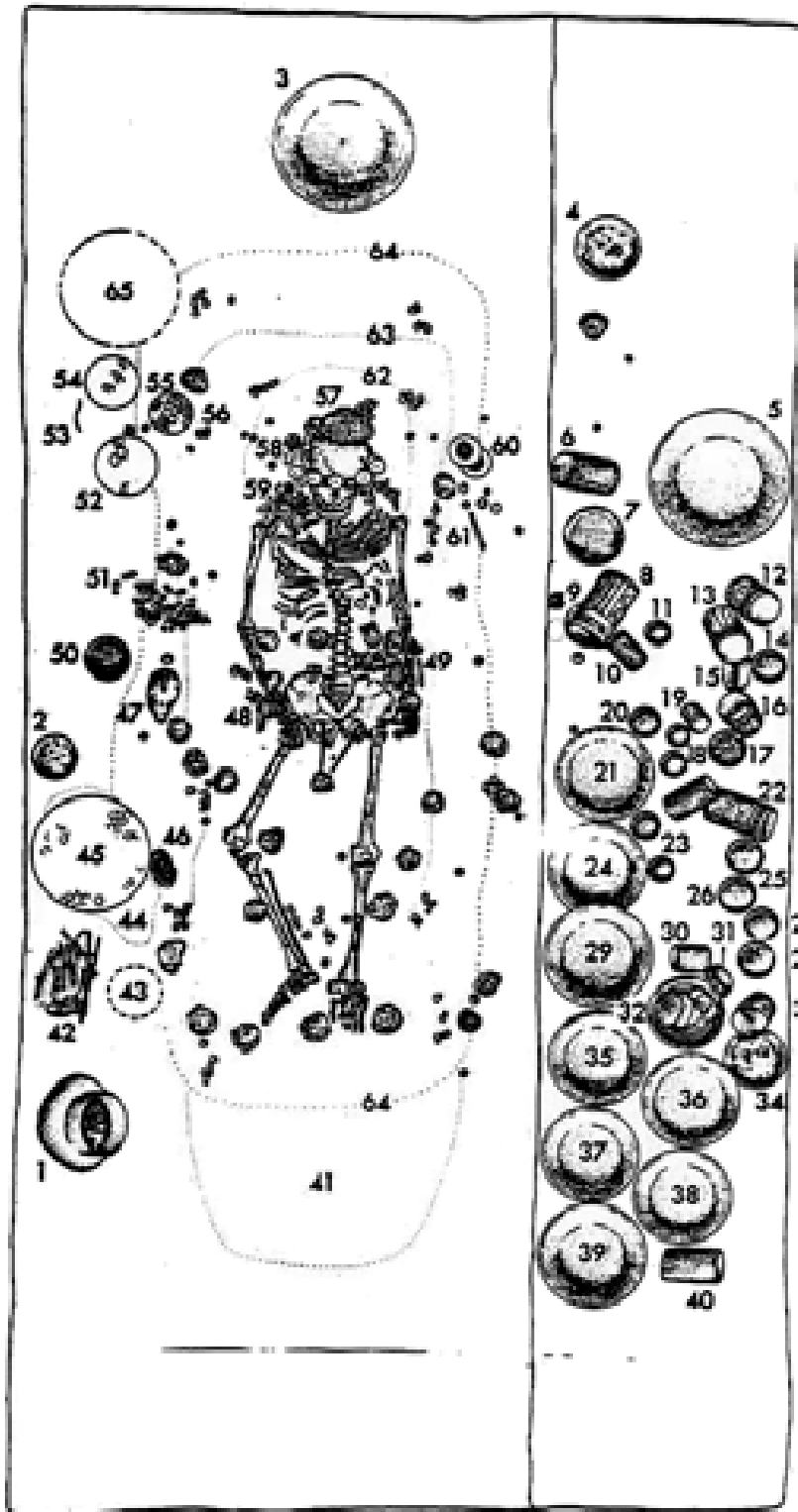

0 1 M.

N
mag

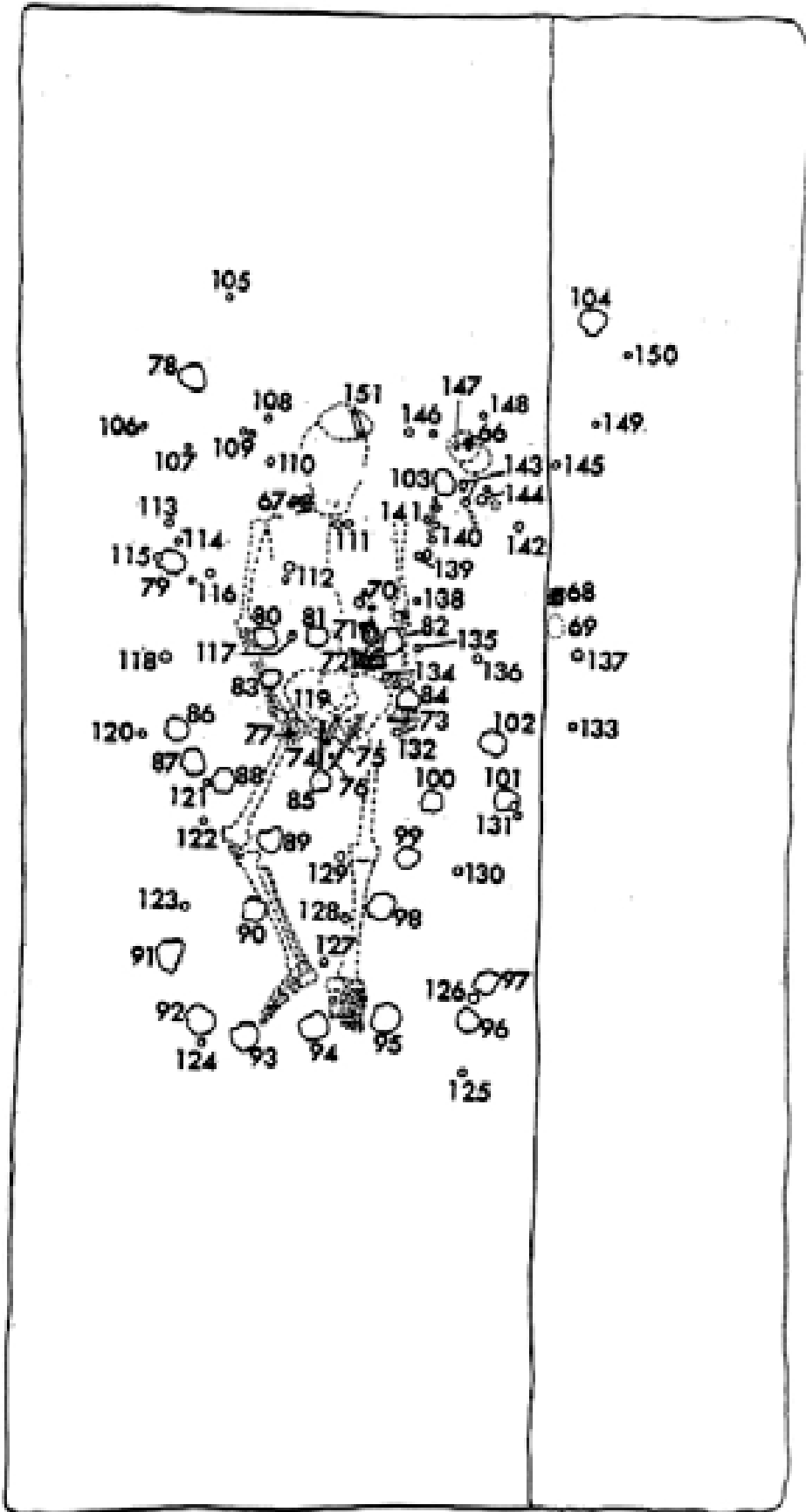

in this report. All comments on artistic style and comparison with other offerings or with other tombs are of the author.

BURIAL 196 OFFERINGS BY PLAN NUMBER

Plan No.	Cat. No.	Description	Location
1	-48	Plain ware cooking pot	B*
2	-3	Polychrome cylinder "Fat man" scene	B
3	-37	Dress-shirt tripod	B
4	-47	Plain, buff ware vessel	A*
5	-36	Large dress-shirt tripod	A
6	-15	Incised and stuccoed cylinder	A
7	-27	Polychrome bowl with dress-shirts	A
8	-5	Incised and stuccoed cylinder	A
9	-30	Polychrome bowl with Qutrefoils	A
10	-24	Black fluted cylinder	A
11	-17	Black cylinder	A
12	-11	Incised and stuccoed cylinder	A
13	-9	Incised and stuccoed cylinder	A
14	-16	Incised and stuccoed cylinder	A
15	-28	Polychrome bowl with dress-shirts	A
16	-6	Incised and stuccoed cylinder	A
17	-10	Incised and stuccoed cylinder	A
18	-19	Black fluted cylinder	A
	-20	Black fluted cylinder	A
19	-21	Black fluted cylinder	A
20	-1	Polychrome cylinder with "bird-men"	A
21	-39	Polychrome dress-shirt tripod	A
22	-14	Incised and stuccoed cylinder	A
	-18	Black fluted cylinder	A
23	-22	Black fluted cylinder	A
	-23	Black fluted cylinder	A
24	-43	Polychrome dress-shirt tripod	A
25	-13	Incised and stuccoed cylinder	A
26	-4	Incised and stuccoed cylinder	A
27	-12	Incised and stuccoed cylinder	A
28	-7	Incised and stuccoed cylinder	A
29	-40	Polychrome dress-shirt tripod	A
30	-25	Cylinder with black spiral on red background	A
31	-31	Black fluted bowl	A
32	-26	Polychrome bowl with dress-shirts	A
	-35	Black rattle-bowl	A
	-34	Orange rattle-bowl	A

Plan No.	Cat. No.	Description	Location
	-33	Plain black bowl	A
	-32	Black fluted bowl	A
	-29	Polychrome bowl with quatrefoils	A
33	-8	Incised and stuccoed cylinder	A
34	-46	Plain, buff ware bowl	A
35	-38	Polychrome dress-shirt tripod	A
36	-45	Polychrome dress-shirt tripod	A
37	-44	Polychrome dress-shirt tripod	A
38	-42	Polychrome dress-shirt tripod	A
39	-41	Polychrome dress-shirt tripod	A
40	-2	Polychrome cylinder, "dancing-man" scene	A
41		Area of hematite and cinnabar	B
42	-74	Unmodified shell	B
	-75	Olivella shells	B
	-76	Shell "tweezers"	B
	-77	Other tweezer ends	B
	-86	Carved-incised bones	B
	-89	Teeth	B
	-90	Worked bone	B
	-91	Worked bone	B
	-92	Bone	B
43	-98b	Hematite	B
	-99	Fragments of wooden bowl	B
44		Area of cinnabar concentration	B
45	-96	Pyrite plaque	B
46	-71	Clam shells	B
47	-50	Jade jaguar	B
48	-55	Jade bead wristlet	B
	-56	Shell pendants for wristlet	B
49	-53	Jade bead wristlet	B
	-54	Shell pendants for wristlet	B
50	-49	Alabaster vessel	B
51	-51	Jade mosaic pot	B
	-83c	Small pearls	B
52	-95	Pyrite mosaic plaque	B
	-77j	Shell fan handle overlays	B
53	-90g	Worked bone	B
54	-94	Pyrite mosaic plaque	B
55	-93	Pyrite mosaic plaque	B
56	-80	Shell and/or cut-pearl pendants	B
57	-69	Spondylus	B
58	-57	Jade headband	B
59	-65	Jade bead necklace	B
	-66	Earplug assemblage	B
	-67	Earplug assemblage	B
	-83b	Pearl	B
60	-52	Large jade earplug flares	B

Plan No.	Cat. No.	Description	Location
61	-52	Throat disks and bead for earplug	B
62		Area of gold colored organic residue	B
63	-101	Jaguar hide (?)	B
64		Black organic deposit	B
65	-100	Wood bowl with stuccoed rim, cinnabar	B
66	-81	Shell and/or cut-pearl pendants	B
67	-84	Pearls	B
68	-73	Cut shell pieces	B
69	-97	Stucco fragments	B
70	-58	Jade pendant and small flares	B
71	-72	Shell pendants	B
72	-79	Jade and shell beads, belt (?)	B
73	-61	Jade bead	B
74	-85	Incised stingray spines	B
75	-59	Jade bead	B
76	-60	Pearl	B
77	-83a	Pearl	B
	-64	Jade bead	B
	-62	Shell bead	B
78			
to	-70	Spondylus shells	B
104			
105			
to	-63	Spherical jade beads	B
150			
151	-62	Carved jade bead	B

CATALOGED OBJECT LIST By catalog number

Catalog Number	Plan number		Location, Bench (B) or Aisle (A)
117A-1	20	Polychrome cylinder, bird-man throne scenes, MT 176	(A)
117A-2	40	Polychrome cylinder, dancing-man throne scene, MT 177	(A)
117A-3	2	Polychrome cylinder, fat man throne scene	(A)
117A-4	26	Stuccoed and incised cylinder vessel	(A)
117A-5	8	" " " " "	"
117A-6	16	" " " " "	"
117A-7	28	" " " " "	"
117A-8	33	" " " " "	"
117A-9	13	" " " " "	"
117A-10	17	" " " " "	"
117A-11	12	" " " " "	"
117A-12	27	" " " " "	"
117A-13	24	" " " " "	"
117A-14	22	" " " " "	"
117A-15	6	" " " " "	"
117A-16	14	" " " " "	"
117A-17	11	Black cylinder with stuccoed rim band	(A)
117A-18	22	Black fluted cylinder	(A)
117A-19	18	" " " " "	"
117A-20	18	" " " " "	"
117A-21	19	" " " " "	"
117A-22	23	" " " " "	"

Catalog Number	Plan number		Location, Bench (B) or Aisle (A)
117A-23	23	Black fluted cylinder	(A)
117A-24	10	" " "	"
117A-25	30	Small red cylinder with black spiral	(A)
117A-26	32	Polychrome bowl with dress-shirt design on exterior walls	(A)
117A-27	7	Polychrome bowl with dress-shirt design, MT 182	(A)
117A-28	15	Polychrome bowl with dress-shirt design on exterior	(A)
117A-29	32	Polychrome bowl with quatrefoils	(A)
117A-30	9	Polychrome bowl with quatrefoils	(A)
117A-31	31	Small black fluted bowl	(A)
117A-32	32	Small black fluted bowl	(A)
117A-33	32	Orange rattle bowl	(A)
117A-34	32	Black rattle bowl	(A)
117A-35	32	Black rattle bowl	(A)
117A-36	5	Large tripod with dress-shirt design	(A)
117A-37	3	Large tripod with dress-shirt design	(B)
117A-38	35	Polychrome tripod with dress-shirts	(A)
117A-39	21	" " " " "	"
117A-40	29	" " " " "	"
117A-41	39	" " " " "	"
117A-42	38	" " " " "	"
117A-43	24	" " " " "	"
117A-44	37	" " " " "	"
117A-45	36	" " " " "	"

Catalog Number	Plan number		Location, Bench (B) or Aisle (A)
117A-46	34	Plain buff ware vessel	(A)
117A-47	4	Plain buff ware vessel	(A)
117A-48	1	Olla, wide, high neck	(A)
117A-49	50	Alabaster bowl	(B)
117A-50	47	Jade jaguar	(B)
117A-51	51	Jade mosaic pot	(B)
117A-52	60	Large jade earplug flares	(B)
	61	Throat disks and bead for earplug assemblage	(B)
117A-53	49	Bracelet of tubular jade beads	(B)
117A-54	49	Shell pendants for jade bracelet	(B)
117A-55	48	Bracelet of tubular jade beads	(B)
117A-56	48	Shell pendants for jade bracelet	(B)
117A-57	58	Jade headband	(B)
117A-58	70	Carved jade pendant	(B)
117A-59	75	Carved tubular jade bead	(B)
117A-60	76	Pearl bead	(B)
117A-61	73	Tubular jade bead	(B)
117A-62	151	Tubular jade bead, carved	(B)
117A-63	105 to 150	Spherical jade beads	(B)
117A-64	77	Flattened-spherical jade bead	(B)
117A-65	59	Necklace of tubular jade beads, 5 strands	(B)
117A-66	59	Jade earplug assemblage	(B)
117A-67	59	Jade earplug assemblage	(B)

Catalog Number	Plan number		Location, Bench (B) or Aisle (A)
117A-68		Jade beads	(B)
117A-69	57	Large spondylus valve over head	(B)
117A-70	78 to 104	Spondylus valves	(B)
117A-71		Clam shells	(B)
117A-72	71	Shell pendants	(B)
117A-73	68	Cut pieces of nacreous shell	(B)
117A-74	42	Unmodified freshwater clam	(B)
117A-75	42	Unmodified, tiny olivellas	(B)
117A-76	42	Shell 'tweezers' with handles	(B)
117A-77	42	'Tweezer' ends	(B)
117A-78		Shell inlays (?)	(B)
117A-79	72	Belt (?) of jade and shell beads	(B)
117A-80	56	Cup-shaped shell pendants	(B)
117A-81	66	Cup-shaped shell pendants	(B)
117A-82		Spherical spondylus shell bead	(B)
117A-83	59	Pearls	(B)
117A-84	67	Pearl necklace	(B)
117A-85	74	Incised stingray spines	(B)
117A-86	42	Carved, incised bones	(B)
117A-87		Adult human skeleton	(B)
117A-88		Jaguar paw bones	(B)
117A-89	42	Unmodified rodent (?) teeth	(B)
117A-90	42	Worked bones	(B)
117A-91	42	Worked bone	(B)

Catalog Number	Plan number		Location, Bench (B) or Aisle (A)
117A-92	42	Worked bone, perforator (?)	(B)
117A-93	55	Pyrite mosaic plaque	(B)
117A-94	54	Pyrite mosaic plaque	(B)
117A-95	52	Pyrite mosaic plaque	(B)
117A-96	45	Pyrite mosaic plaque	(B)
117A-97	43	Painted stucco fragments	(B)
117A-98	43	Unidentified mineral, cinnabar (?)	(B)
117A-99	43	Fragments of wooden bowl	(B)
117A-100	65	Wood	(B)
117A-101	63	Jaguar hide (?)	(B)
117A-102		Unidentified white powdery substance	(B)
117A-103		Unidentified carbonized remains of 117A-48	(B)
117A-104		Unidentified contents of 117A-3	(B)
117A-105	65	Plaster, impression on of wooden bowl	(B)

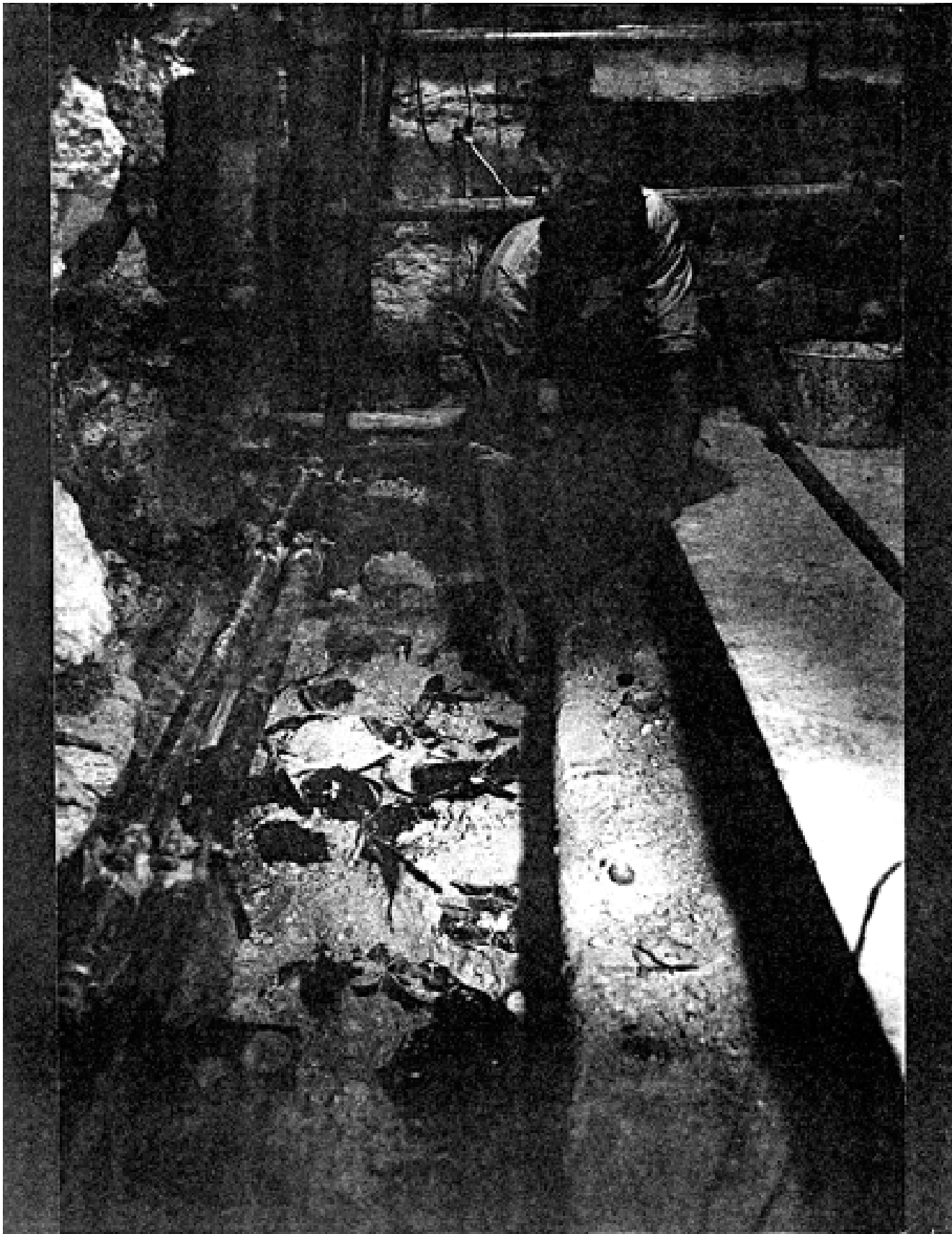

Photo 44 The writer removing collapsed debris from around offerings on the floor.

As the tomb was separated architecturally into two divisions--a raised platform or bench and a (lower) floor area--the description of the artifacts will be so divided.

THE FLOOR AREA

On the north side of the raised platform there was a narrow strip of floor .72 m. wide, running the 4.50 m. length of the tomb. Plastered walls of the tomb formed three boundaries, and the 27 cm. high raised platform formed the south boundary. The floor of the aisle was uneven and rough, somewhat due to the weight of the collapsed walls but perhaps also due to hurried and/or sloppy construction. Except for several jade beads, shells, and possibly some wooden objects which rolled off the curved edge of the bench, all the offerings in the aisle were pottery vessels.

The offerings will be described more or less as they were situated on the floor, east to west. The majority of the offerings in the aisle were situated in groups, and the groups will always be discussed as a whole (by catalog number which unfortunately does not agree with location). One of several exceptions to the east-west sequence of description will be the two polychrome cylinders (one found at the east end of the aisle, the other in the middle), which have throne scenes painted on them. The description of these vessels will be put together at the end of the section on aisle offerings just before the description of the polychrome cylinder vessel

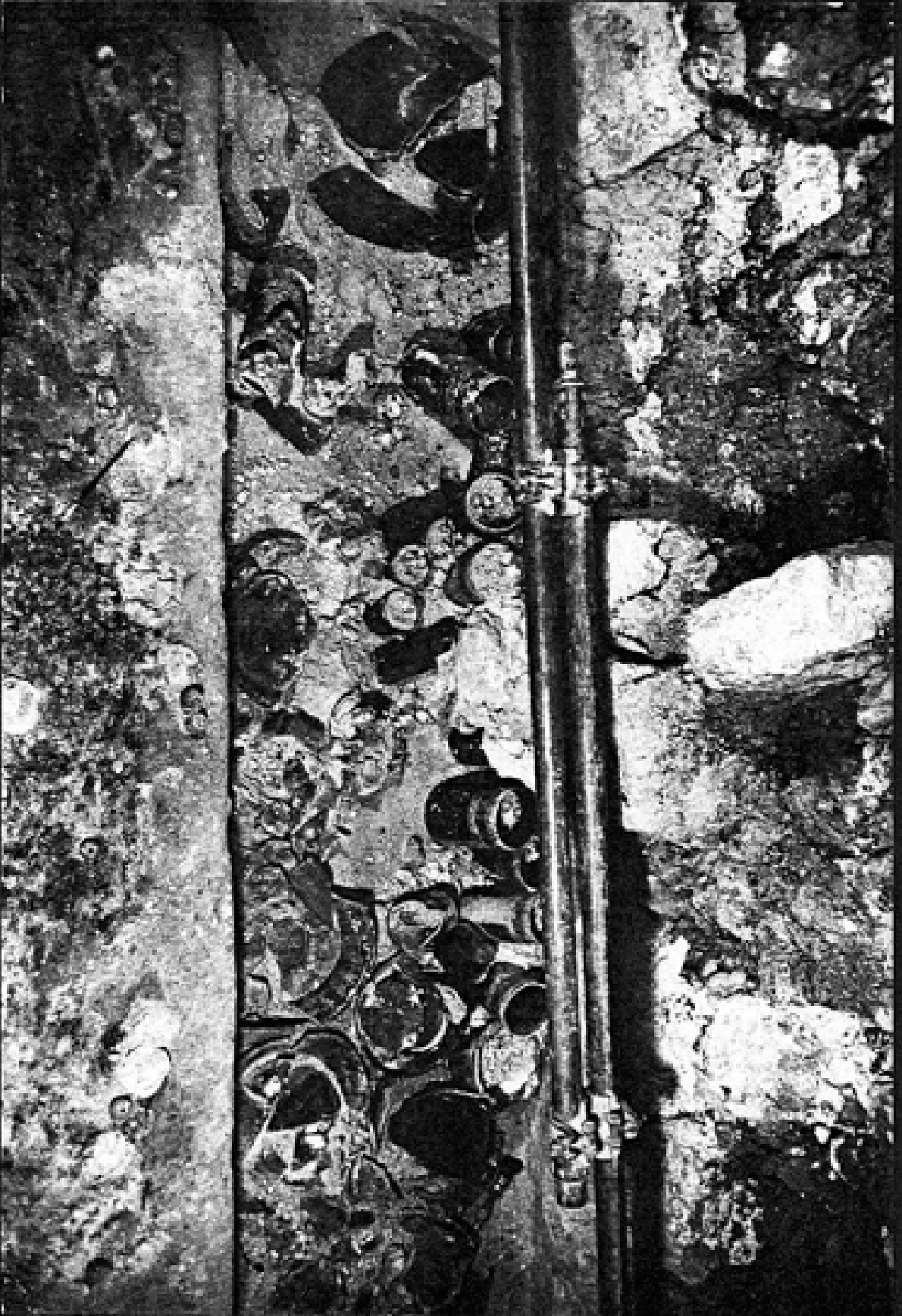

Photo 45 Bu. 196, offerings on the floor.

Catalog #	Shirts on walls	Shirts on base	Interior center design	Height	Rim Dia.	Buttons	Exterior base & feet unstipped, unpolished	Exterior walls & interior slip. & polish	Buff Paste
-38	12	8	kan cross	11.4	17.5	4 to 5	yes	yes	yes
-39	12	6	glyph	10	28.6	5 to 7	yes	yes	yes
-40	12	9	plain	10.6	31	5 to 7	yes	yes	yes to light orange
-41	12	8	plain	10.5	30.4	4 to 5	yes	yes	yes
-42	8	5	plain	10.5	28.5	4 to 6	yes	yes	yes
-43	9	5	plain	10.4	17.5	4 to 6	yes	yes	yes
-44	11	8	plain	11	28	2	yes	yes	yes
-45	10	0	design	11.5	29.5	5 to 7	yes	yes	yes
-36	12	9	glyph	24	41.2	3 to 7	yes		yes
-37	12	8	kan cross	13.5	40		4 to 6		yes

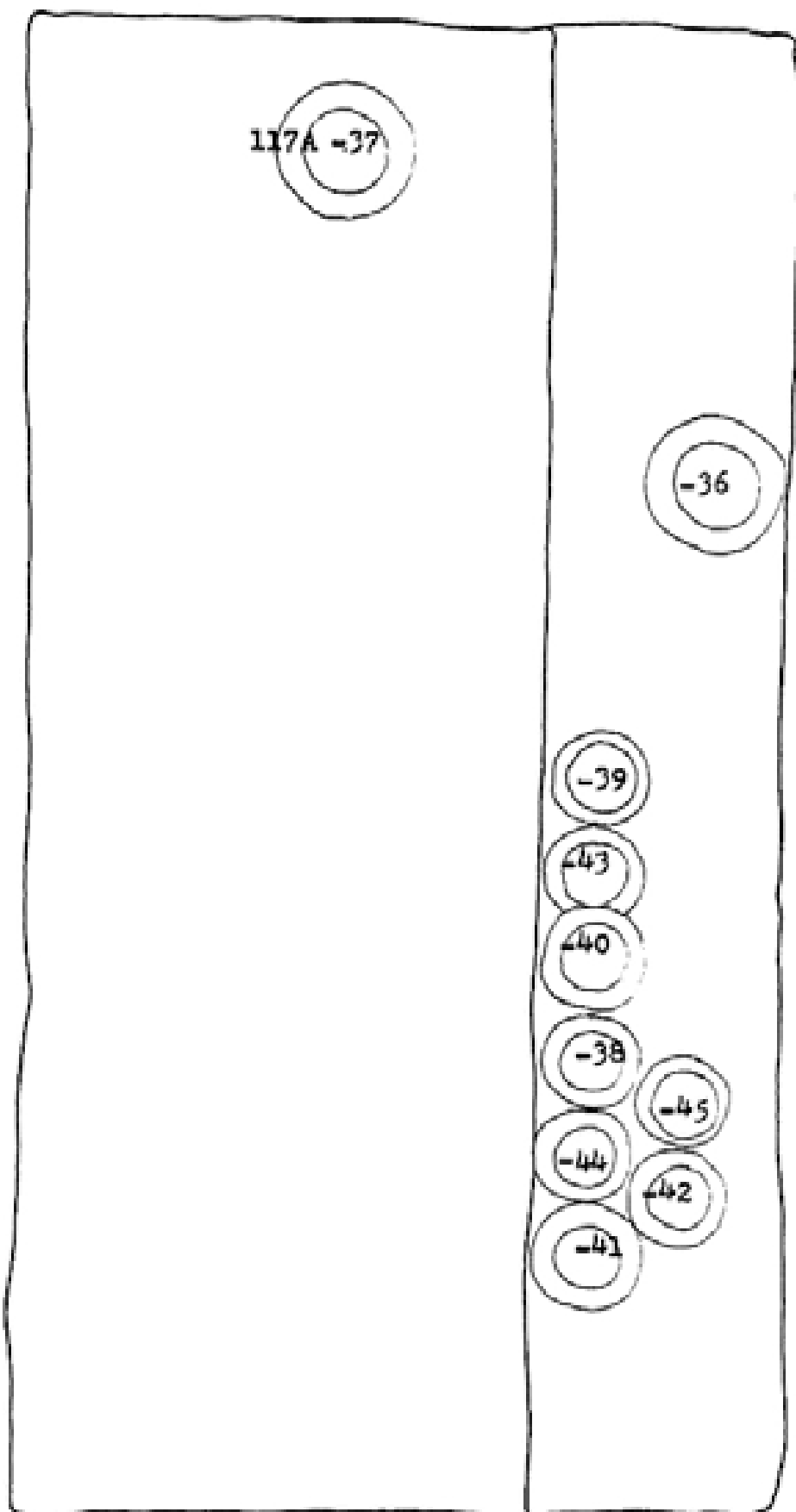

Fig. 28 Detail plan showing location of tripod plates.

which was found on the bench, so that the designs of the three vessels may more easily be compared.

Polychrome Tripod Plates with Dress-Shirt Designs

Next in the aisle after a polychrome cylinder vessel was a group of eight vessels of similar design placed in two rows (Fig. 28). Two were placed together near the north wall and six in an adjacent row next to the bench. All were too smashed for any former food remains to have been present in them. In the floor under the fragments were occasional traces of powder that could have been spilled, decayed food-or could have fallen from the bench, which was covered with decayed matter of all sorts. Heights, rim diameters, colors, number of dress-shirt panels etc. are compiled in a chart on p. .

At the west end of the row of incised cylinder pots were the broken remains of a large tripod plate with a dress-shirt design on the interior (Plan #5). On the bench west of the head of the deceased was another large tripod plate (Plan #3). Both these vessels, although not members of the group of eight plates, will be included in the following discussion because they are of similar design.

Five of the vessels have plain centers, however, even within this similarity there is variation in that some have two concentric rings of black, between which there is orange, while two have just one black center ring (117A-42,-43). One



Photo 46, east.

Bu. 196, dress-shirt design tripod plates as found.



Photo 47, center.



Photo 48, west.

Photo 49 117A-39

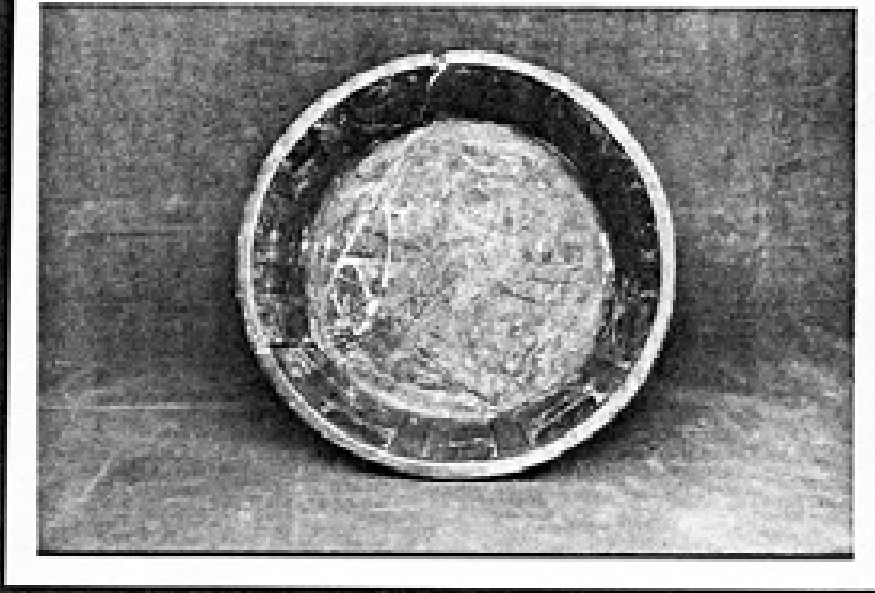

Photo 50 117A-40



Photo 51 117A-44



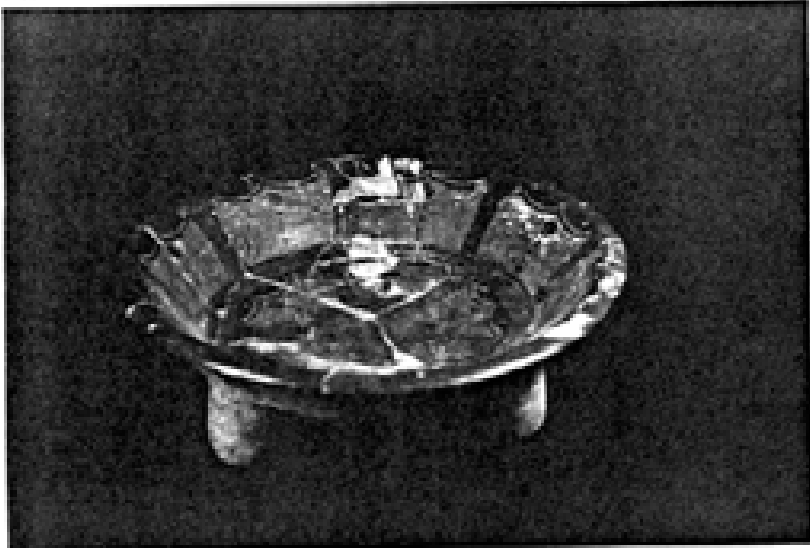

Photo 52 117A-43

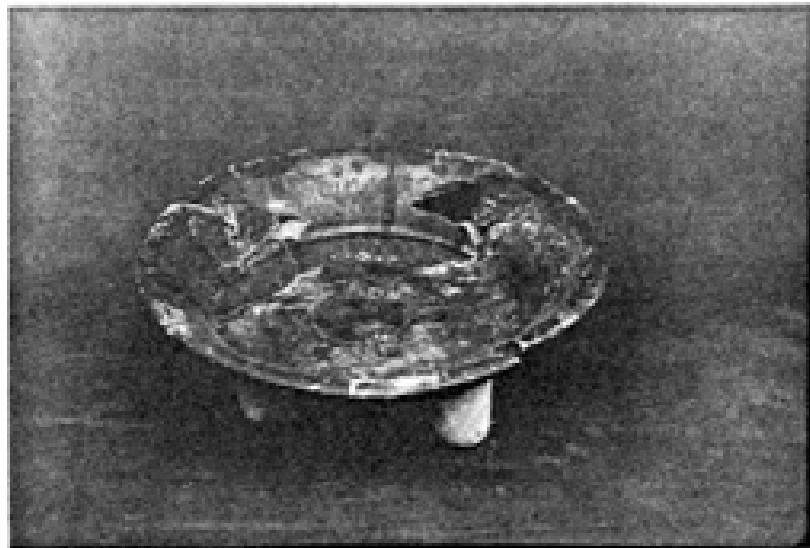

Photo 53 117A-45

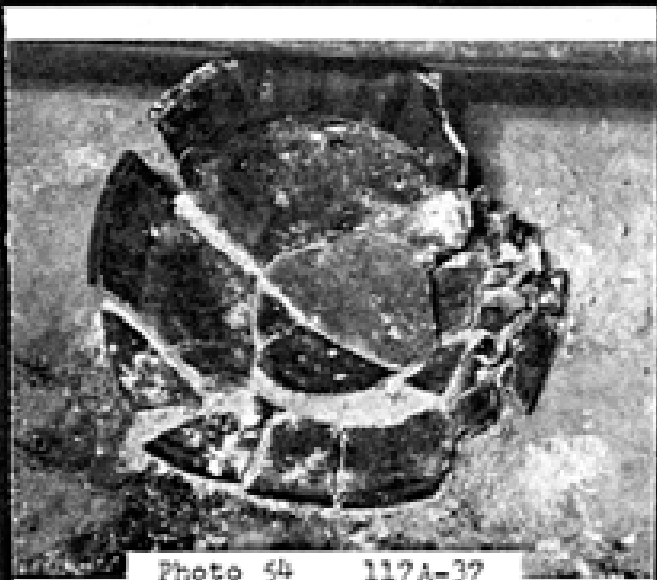

Photo 54 117A-37



Photo 55 117A-36

117A-38/36 B. 196

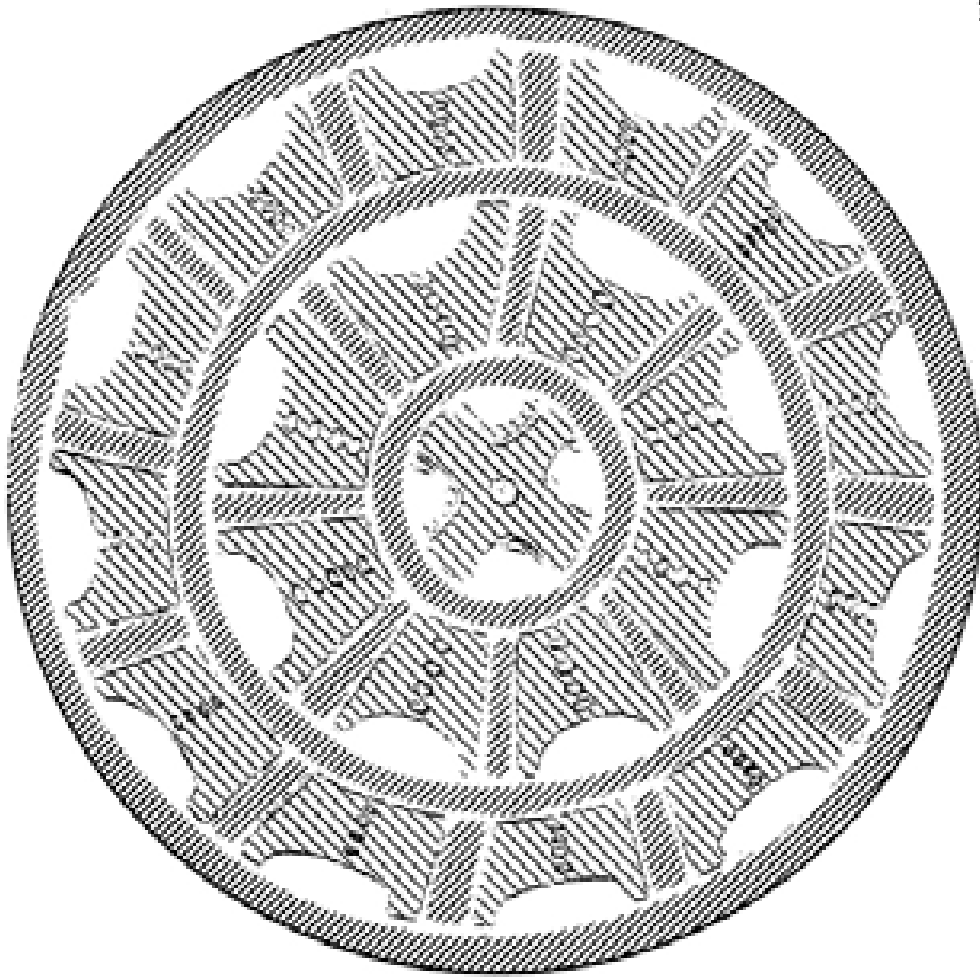
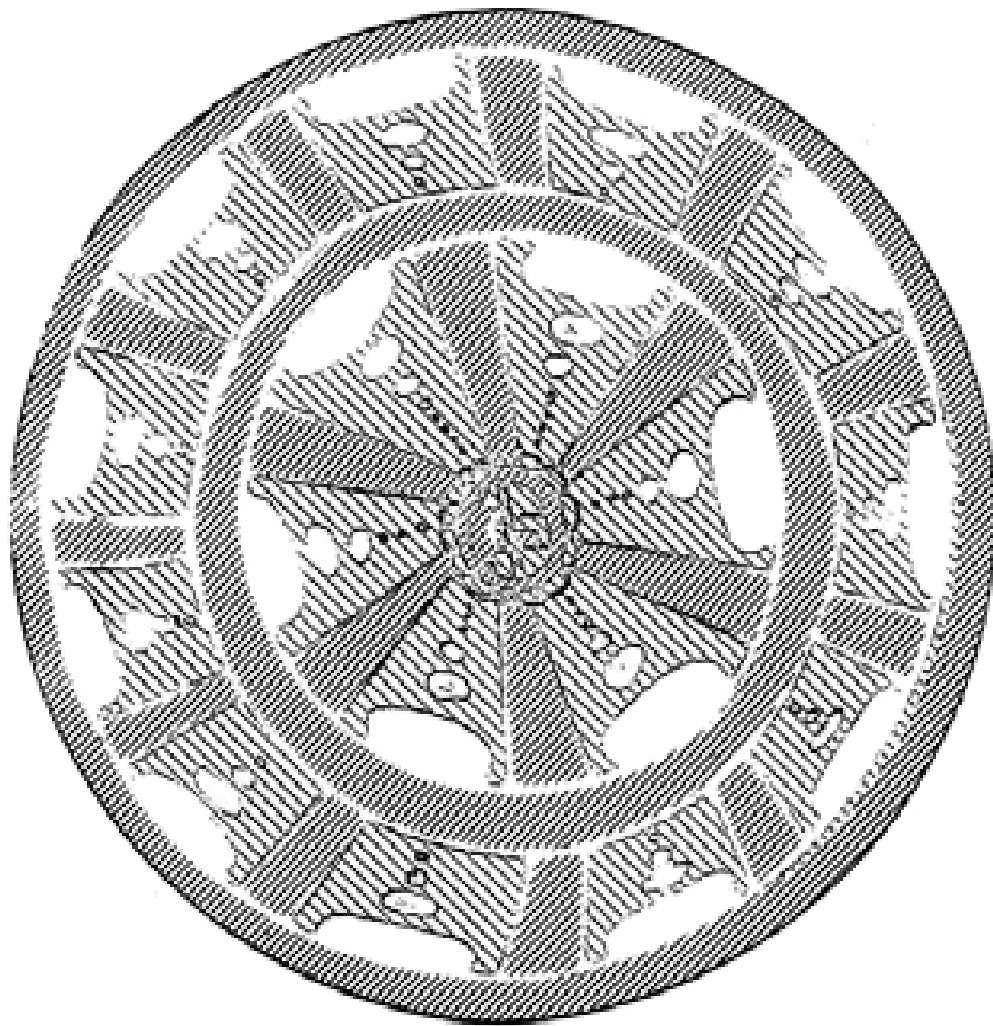

Fig. 29 117A-38



261-A 45/10 1000

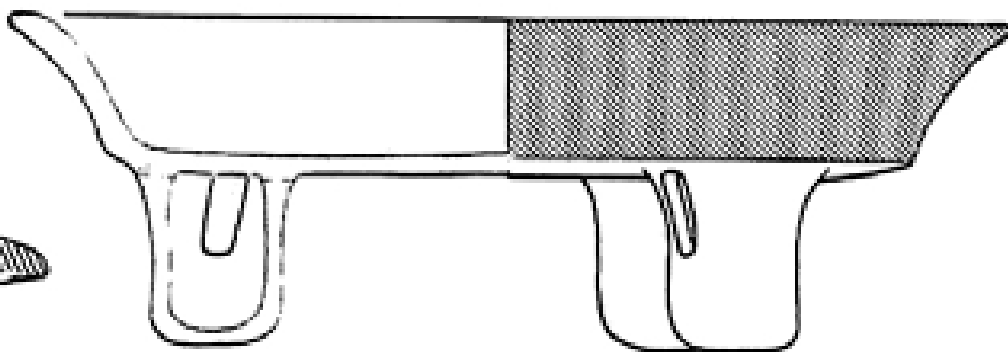
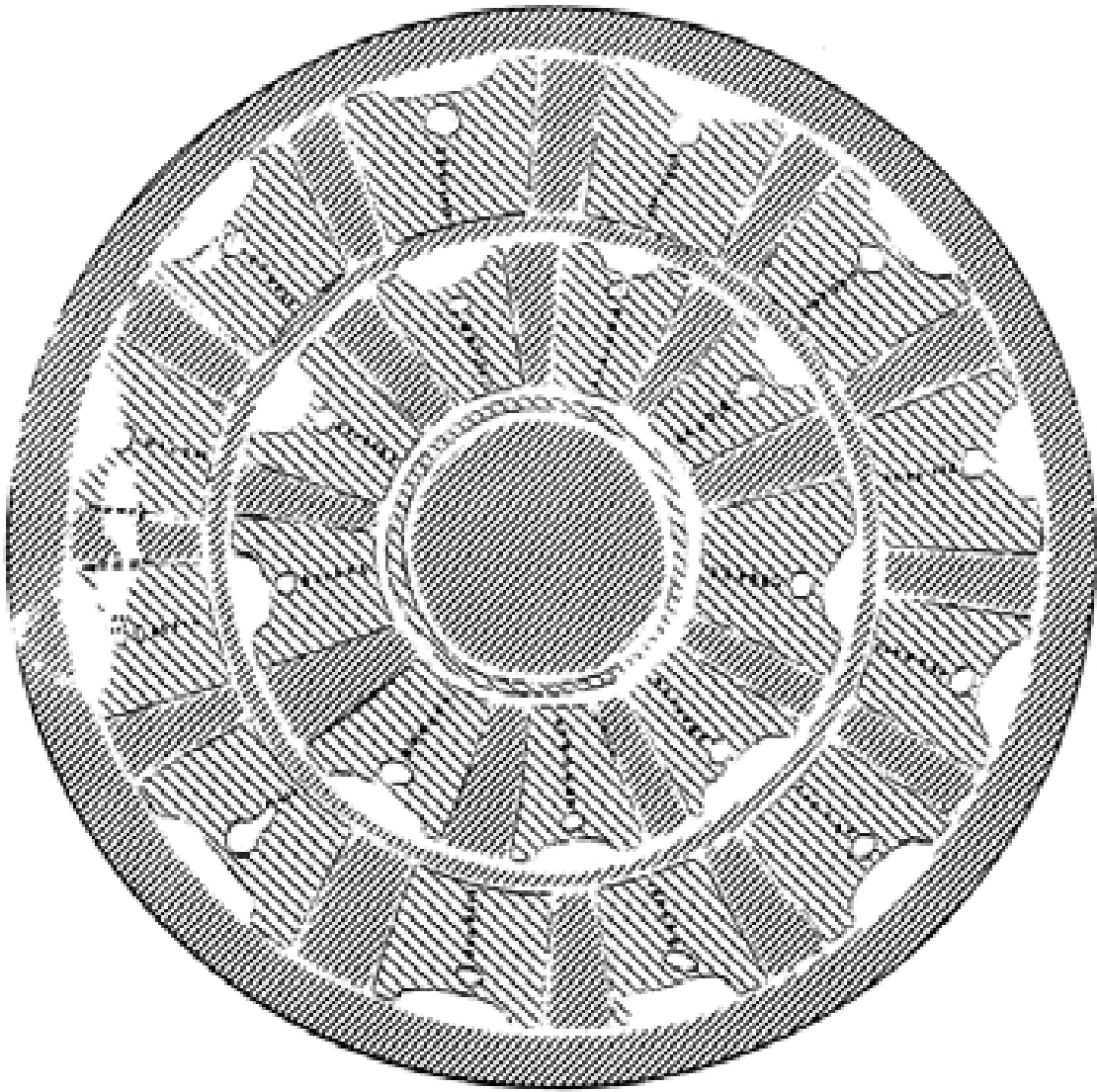
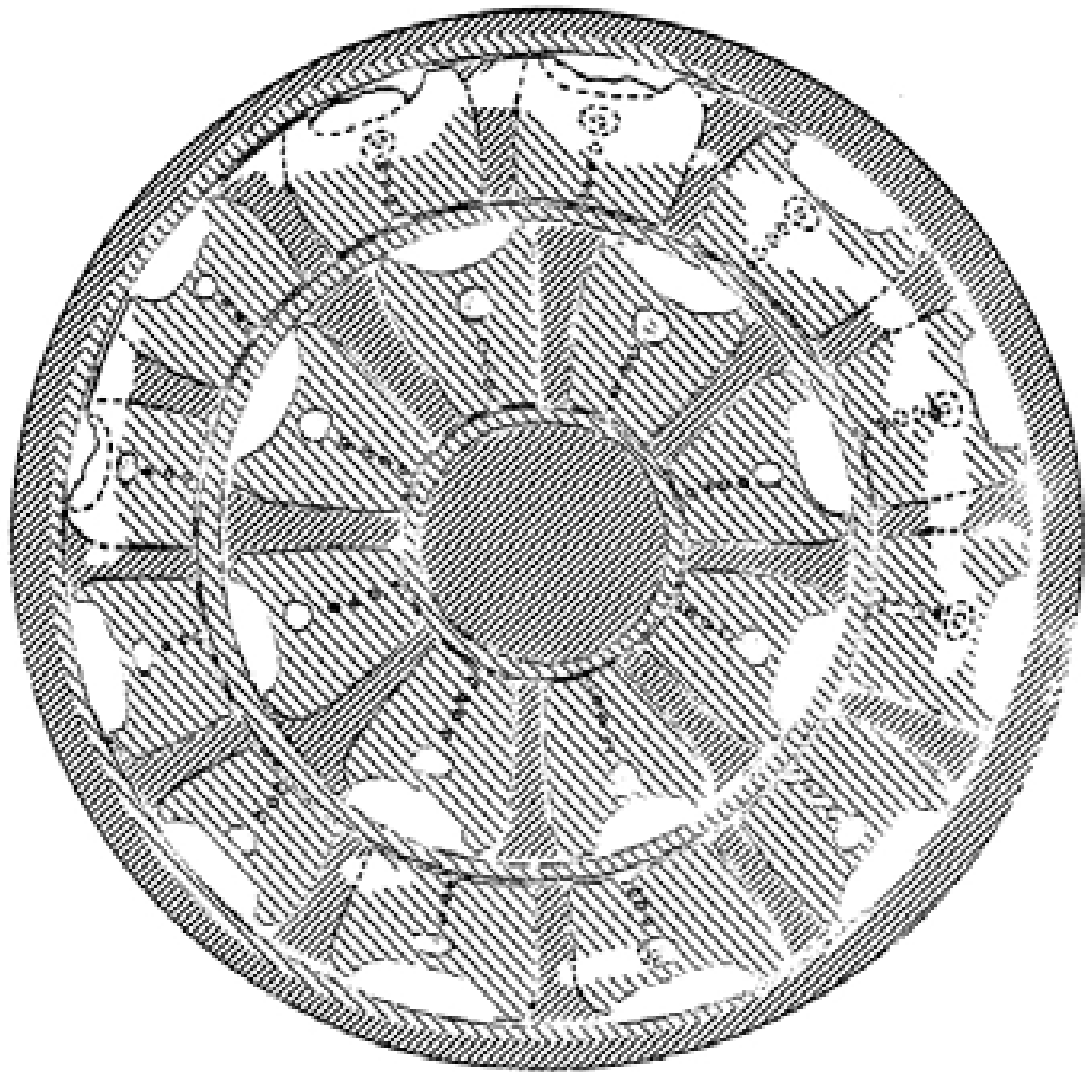

Fig. 30 117A-39



117A-40/36 B 19c

Fig. 31 117A-40



117A-41/36 3.96

FIG. 32 117A-41

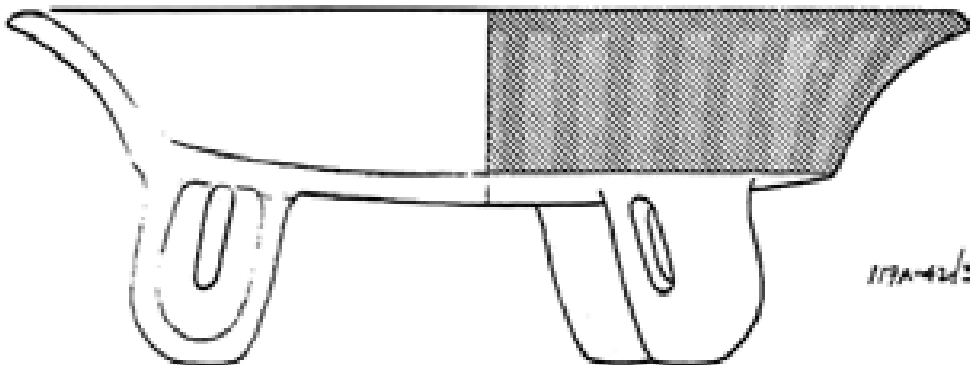
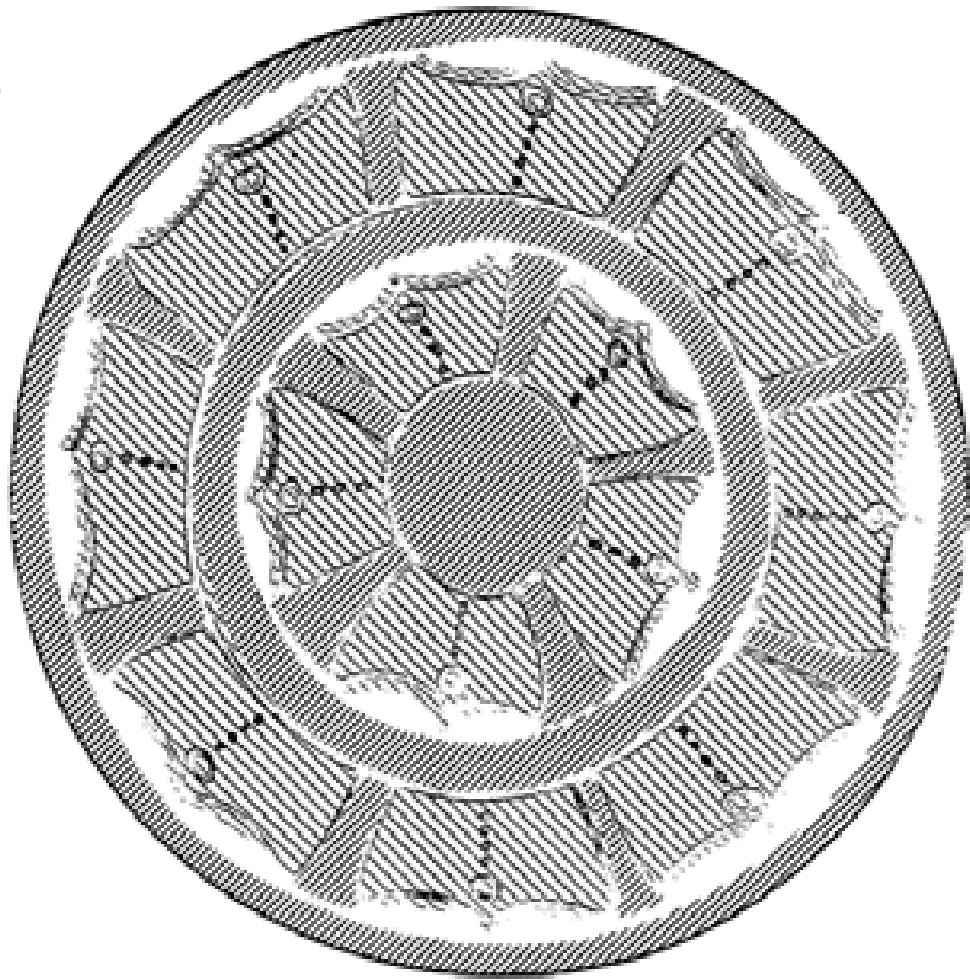
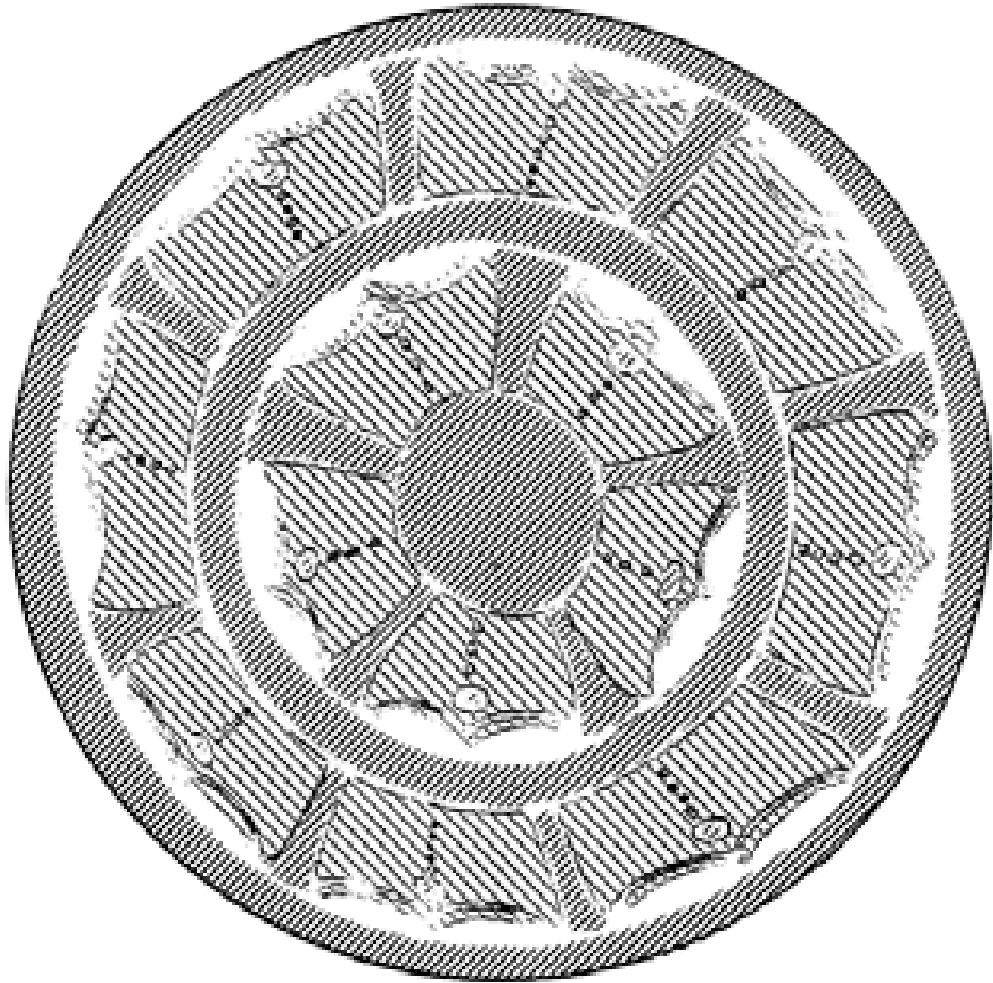

FIG. 33 117A-42

117A-42/36

117A-42/36



117A-43/36 B.M.C.

Fig. 36 117A-43

117A-44/36 B.196

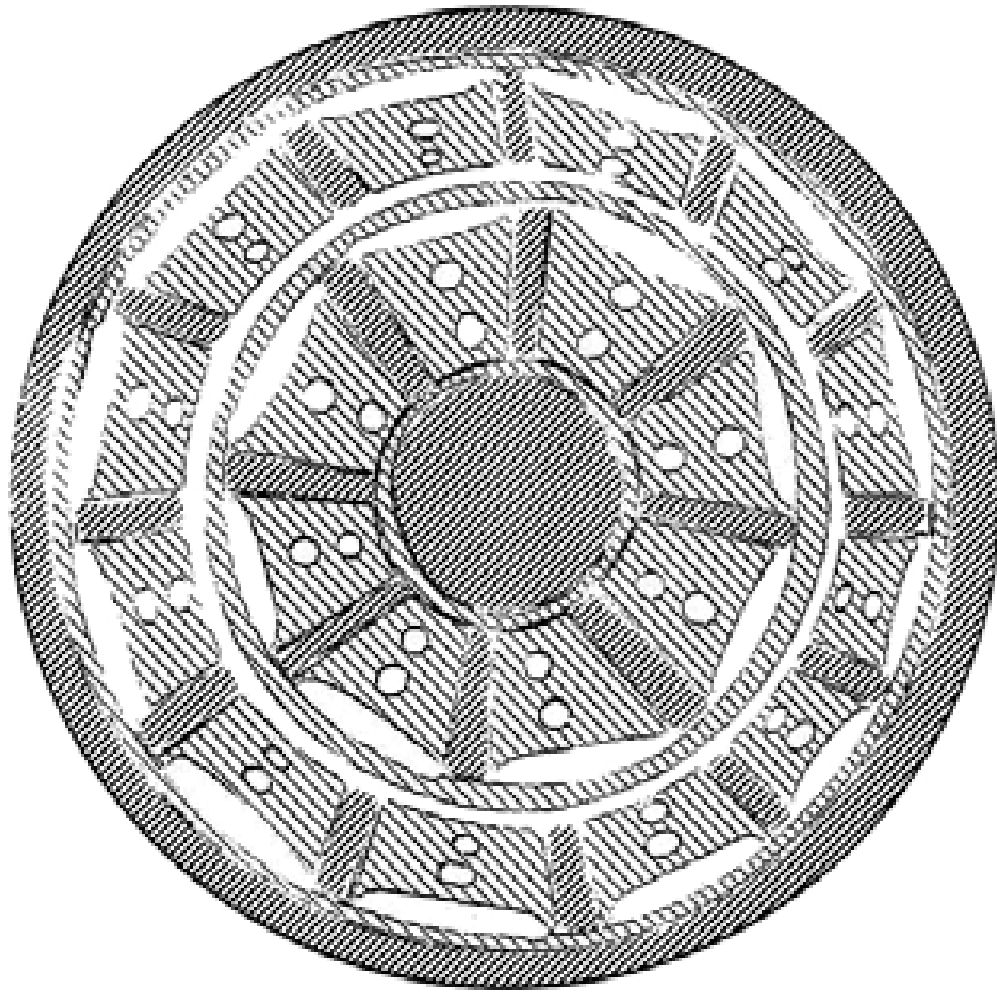

Fig. 35 117A-44

117A-40/36 B.M.C.

117A-45/36 B.M.C.

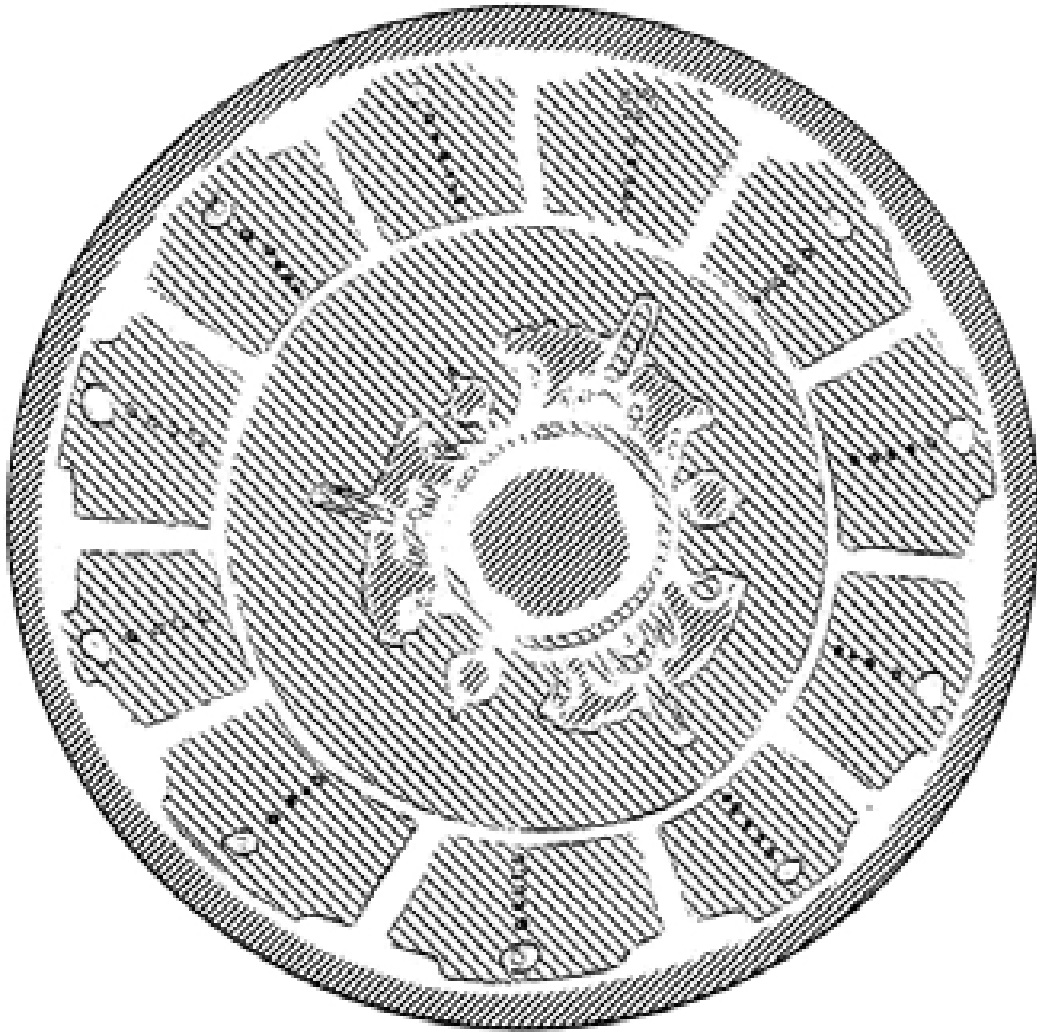

Fig. 36 117A-45

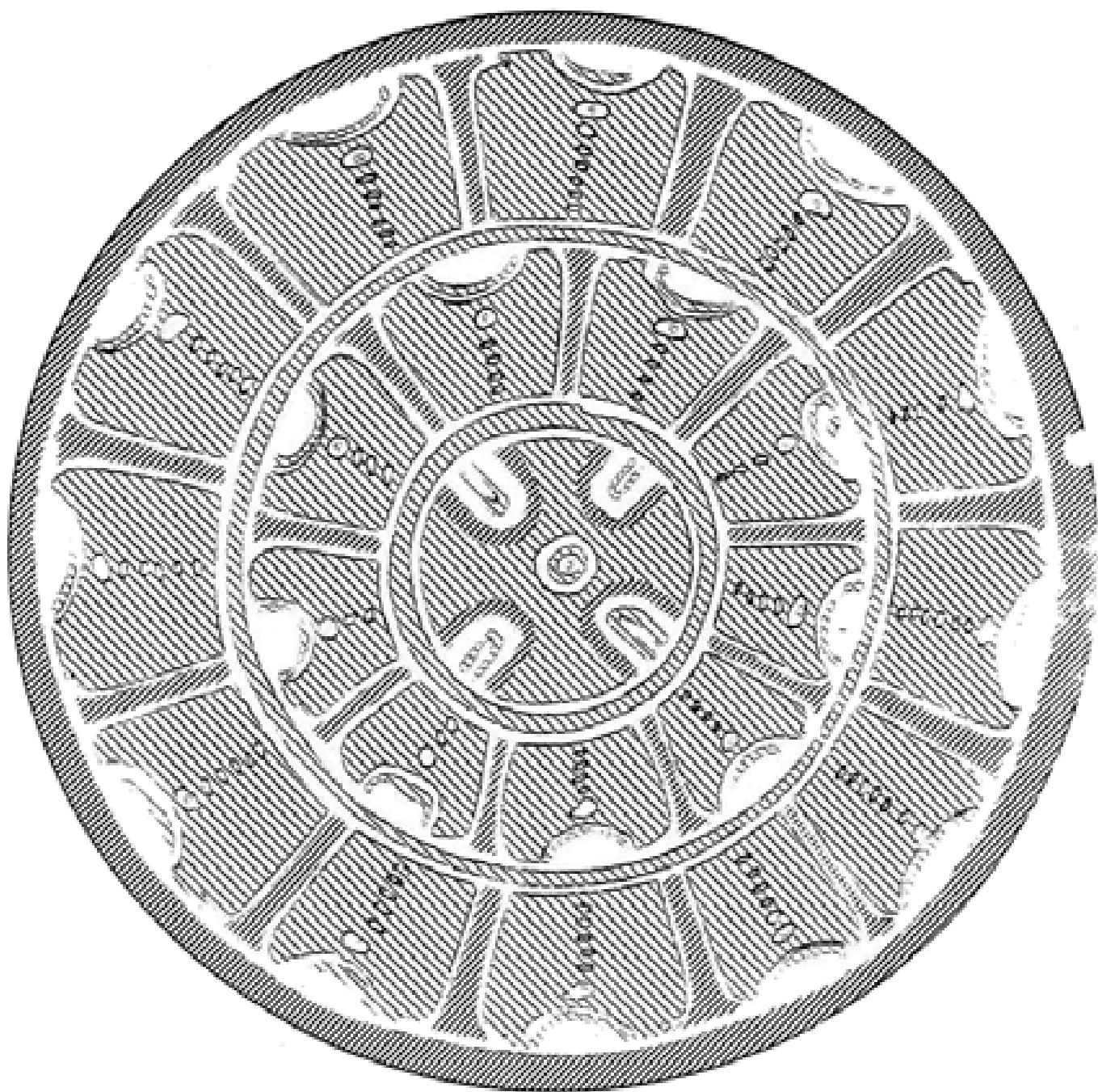

Fig. 37A 117A-36

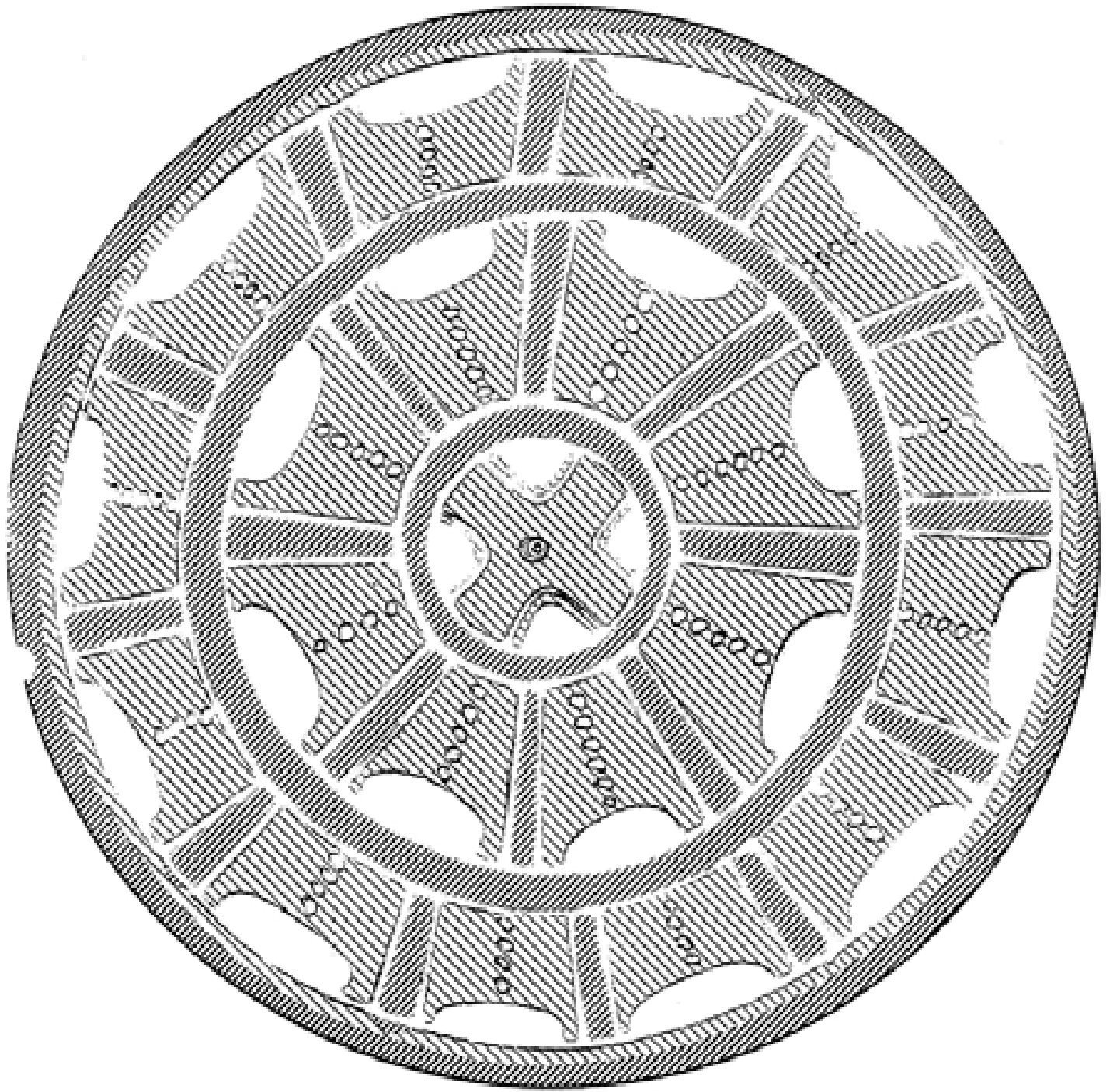

Fig. 37B 117A-37

10/25/37

BURIAL 196

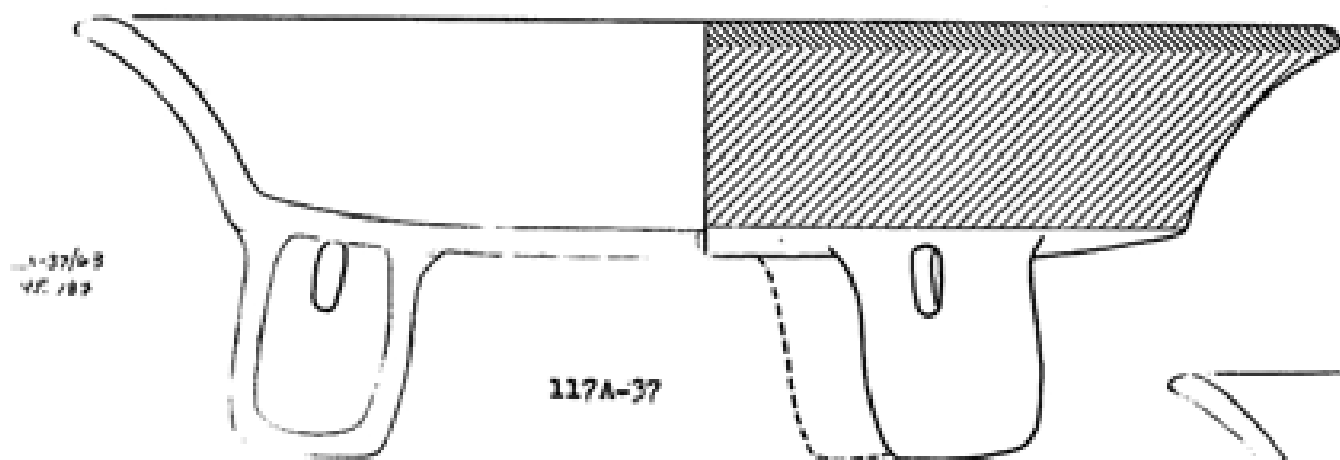
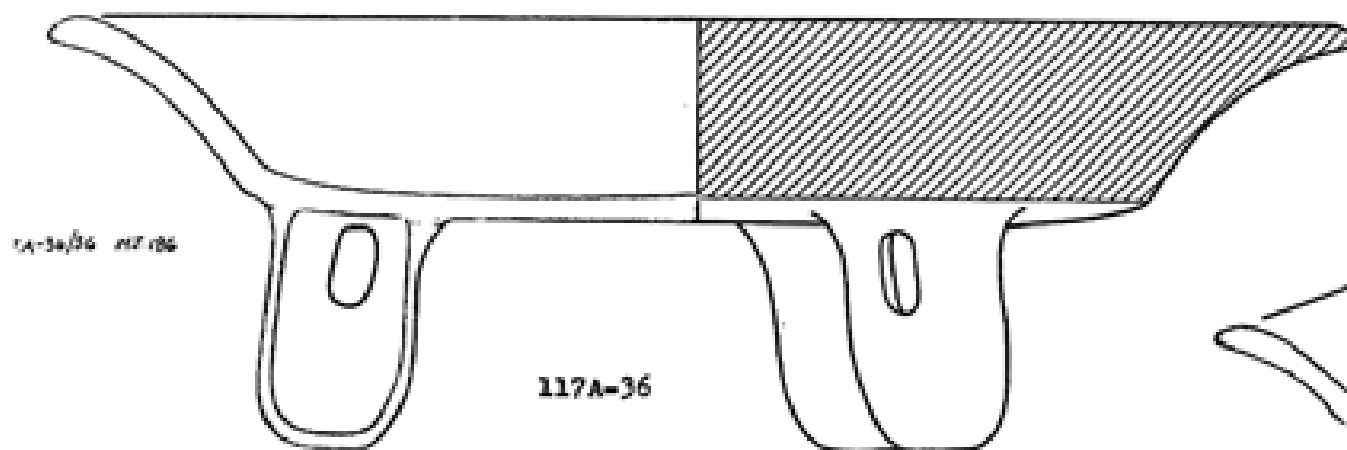

Fig. 38 Large tripod plates.



of the vessels has a kan cross in the center, as does one of the large tripod plates (on the bench); another has an unidentifiable glyph (117A-39). The most unusual center design occurs on 117A-45, which has some sort of multiple flower design of possible significance.

The dress-shirt panels vary in the number of black semi-circles per panel. The standard form possesses one major black element per panel; but 117A-45 has one black element shared by two panels, and 117A-42 and 43 have two per panel which are double outlined.

Within the panels, the number of buttons varies; but, at the top, there is usually one major button, except in 117A-37, -38, -44. In some cases, the top button has a double outline; and, in one case (117A-43), the interior is red, which is quite different from the orange of the panel. The painting was not always done very carefully, and in 117A-40 the paint ran down the row of dots.

Possible Origins of the Dress-Shirt Design

The similarity between the system of dots or circles of the dress-shirt design to those of the caban glyph suggests that the dress-shirt design may be derived from the glyph. The caban glyph as a decorative element occurs most frequently in the codices, and here there is one most interesting representation of it. Basically, the caban glyph consists of two infices, a question mark-shaped squiggle and a pattern



a

b

c

d

e

f

g

h

Fig. 39 Possible origins of 'dress-shirt' design.

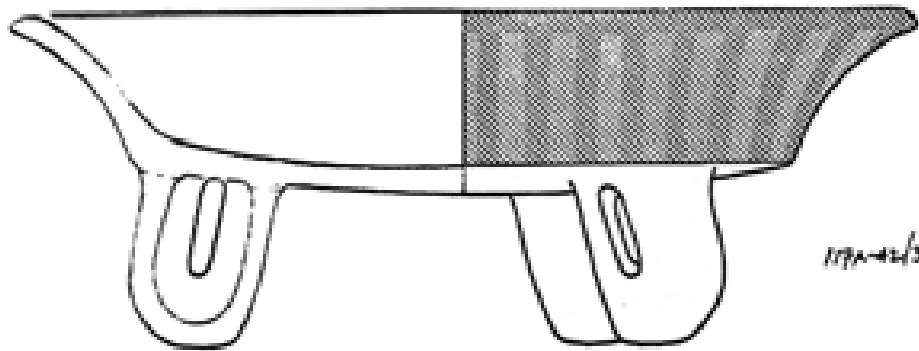

117A-42/36

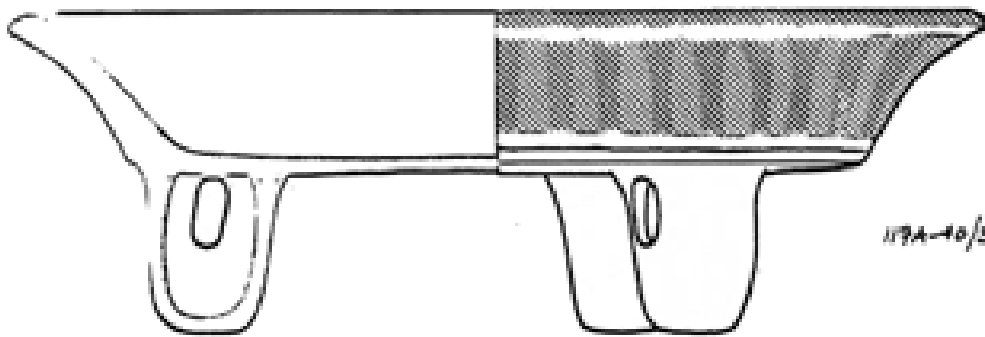

117A-40/36

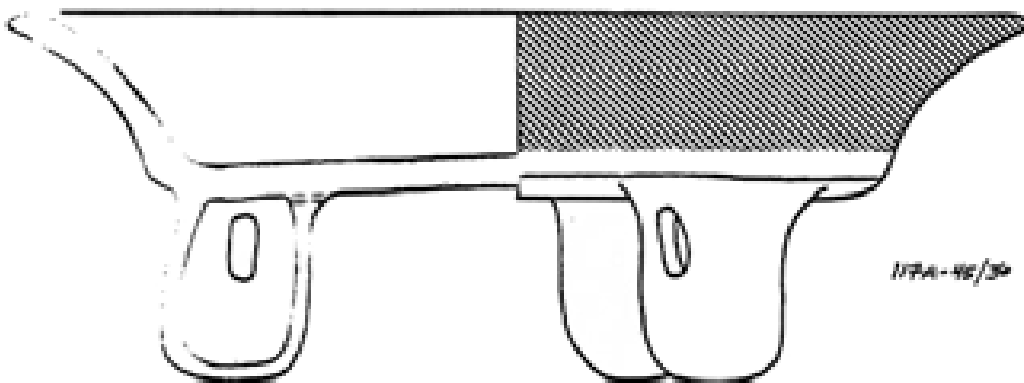

117A-46/36

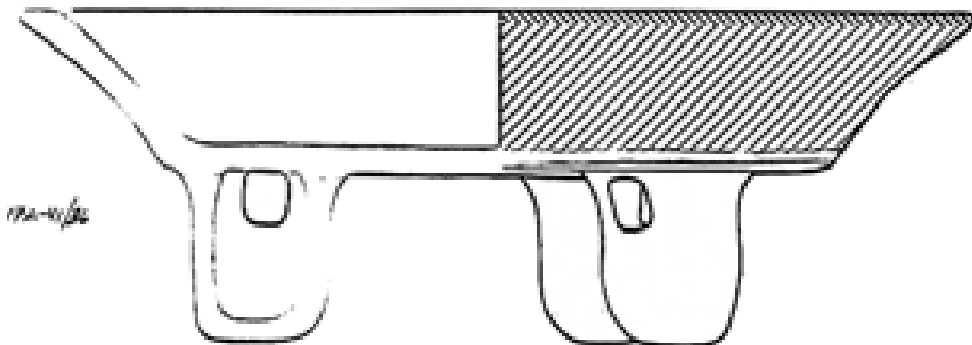

117A-41/36

Fig. 40 Dress-shirt design tripod plates.

177A-37/43
REV. 100

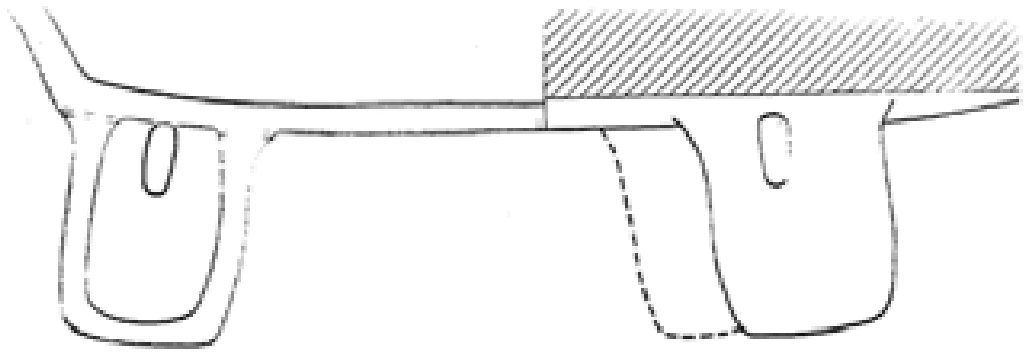

177A-40/36

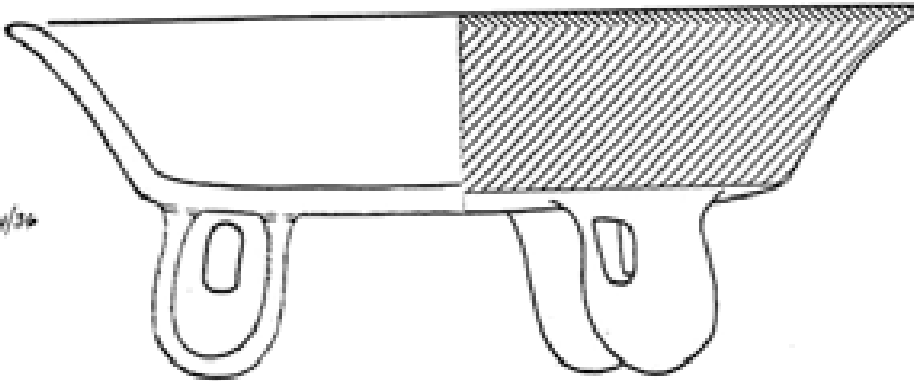

2

177A-43/36

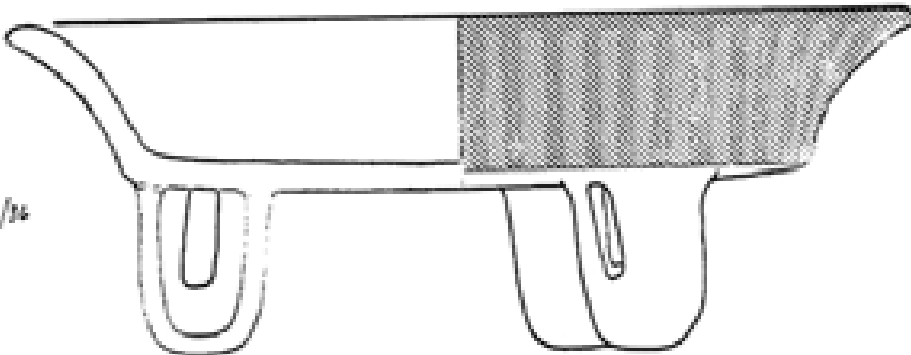

2

177A-38/36
REV. 100

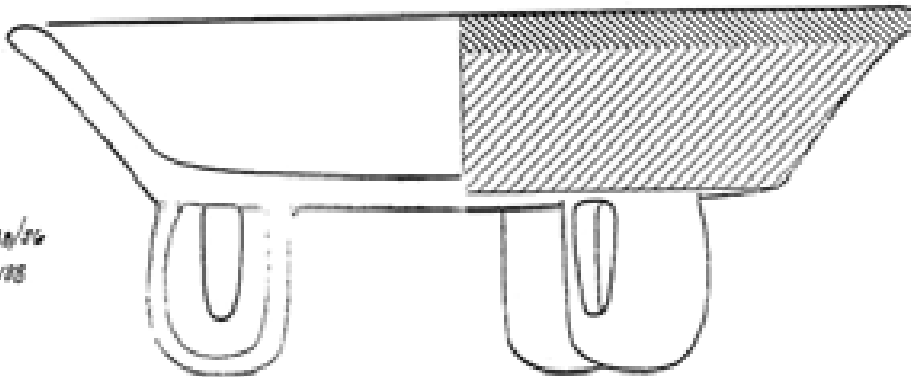

2

Fig. 41 Dress-shirt design tripod plates.

177A-38/36

of dots always with an extra large dot or circle at the top. In the codices these elements are often separated (Fig. 39); or, they can occur together as in the glyph, demonstrating that the glyph is the origin of the design. One crucial design links the squiggled question mark with the dots (Fig. 39, g); here, the dots have a curl instead of a black spot as an upper element. A further link between the dress-shirt design and the caban glyph is the fact that in the glyph there is a "panel" perfectly delineated by interior lines within which occurs the potential "dress-shirt" design.

Further Variation Within the Group of Tripod Plates

The decoration of the exterior sides of the tripod plates also varies. Three of the plates' sides have vertical red-on-red stripes (117A-30, -42, and -43). Two plates (117A-38, -44) have orange walls with a red rim band, as does one of the large plates (-37). 117A-41 is similar but has a black base band. 117A-45 has orange-red exterior walls with a 1 cm. black band at the base, while the large plate from the aisle has a completely orange color on the exterior walls.

Even the clay from which the vessels was made varied. The writer is not a ceramic specialist and does not recognize the different types; the official ceramicist's report is not yet available.

It can thus be seen that there are no two vessels exactly alike and only two that are closely linked (117A-42 and

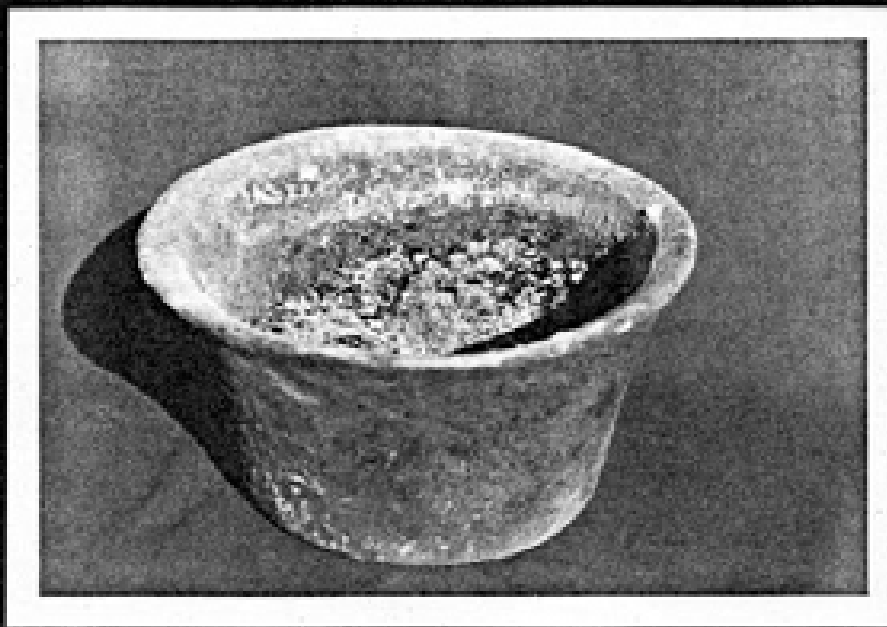

Photo 56 Plain ware vessel, 117A-46.

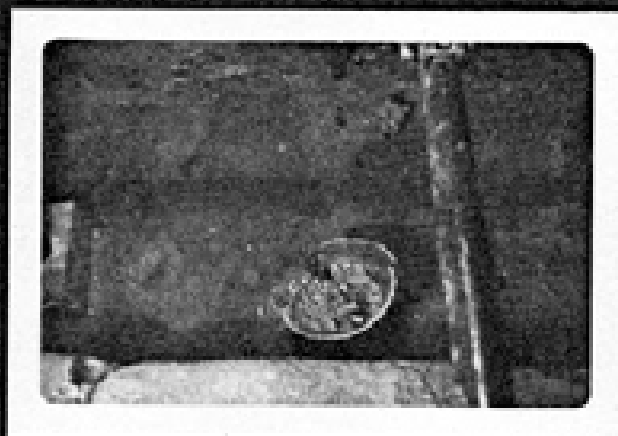

Photo 57 Plain ware vessel, 117A-47.

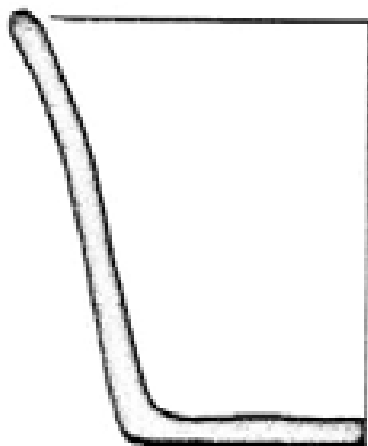

FIG. 42A 117A-47

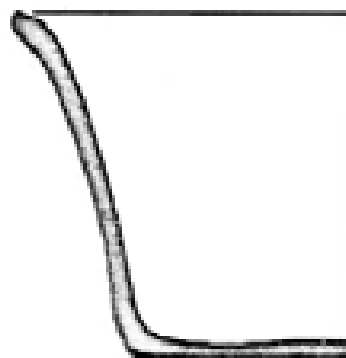

FIG. 42B 117A-46

-43), the difference being in size and the number of panels on the interior walls. Eight is not known to be a symbolic number; rather, nine would be the number expected, or possibly thirteen.

Plain ware Vessels

In the burial there were three vessels which looked more utilitarian than ceremonial. Two of these were similar to one another and were found at opposite ends of the aisle. They will be both discussed together here.

Flat-Bottomed, Flaring-sided Vessel Plan # 34 117A-46 Fig. 42G Photo 56

Against the north wall, at the east end of the group of 13 "god pots," was a plain, undecorated vessel. It was flat-bottomed with slightly flaring sides and an everted rim; buff paste and was both unslipped and unpolished. What may have been the carbonized remains of food filled the vessel halfway. This utilitarian pot was 10 cm. high; its rim diameter was ca. 19.4 cm.

Flat-bottomed, Flaring-sided Vessel Plan #4 117A-47 Fig. 42a Photo 57

This container lay by itself towards the west end of the aisle; the shell near it had slipped from the bench. There was 3 cm. of decayed "food" in the bottom of the vessel



Photo 58 Looking west at the pile of vessels.

which was badly warped and split but was similar to 117A-46 except that it was slightly larger (height ca. 12.5 cm., rim diameter ca. 19.6 cm.).

Pile of Vessels (Plan # 32)

Hemmed in on two sides by dress-shirt design tripod plates was a pile of seven vessels. The significance of this grouping is not known. Some of the upper ones appear to have been originally upside down. The description will start with the bottom-most vessel.

Flat-bottomed Polychrome Bowl 117A-26 Fig. 43 Photos 58, 59

This, the bottom-most vessel of the pile, lay directly on the floor, with no cinnabar under it. All the other bowls were more or less contained within it, starting with the black rattle-bowl. On the underside of the rattle-bowl was a tiny bit of soft powder, suggesting decayed food, but the otherwise clear interior bottom of the dress-shirt design bowl did not show indication of any more powder.

The sides of the bowl flared slightly; its paste was buff, and the entire vessel was slipped and polished. A dress-shirt design (a total of nine panels) in black, red, and cream covers the exterior, while the interior has a red rim and base; a red-on-red vertical stripe pattern decorates the walls. The exterior base has traces of a red-on-red

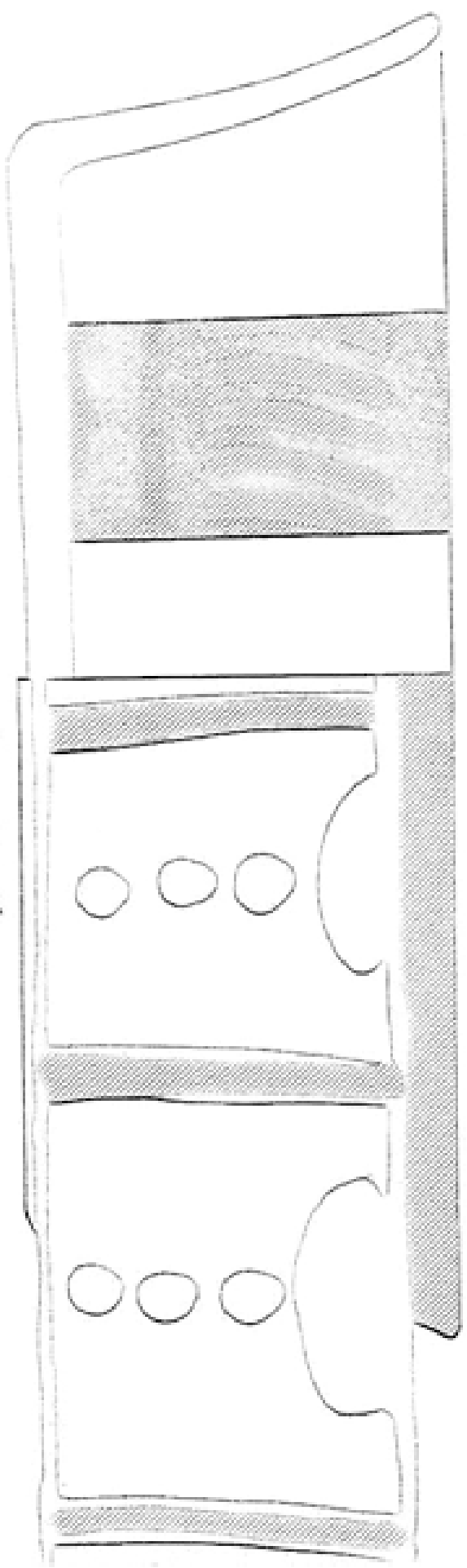

PLG. 43 117A-26

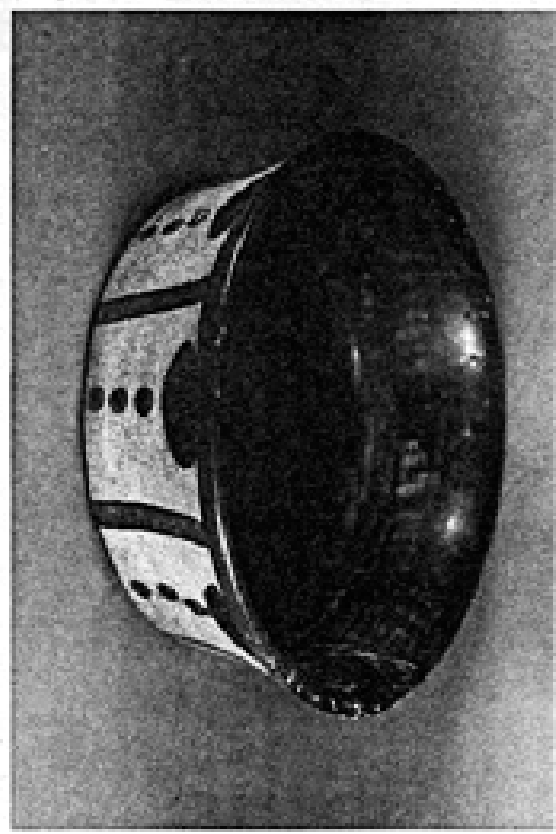

Photo 59 Plate bottomed bowl, 117A-26.

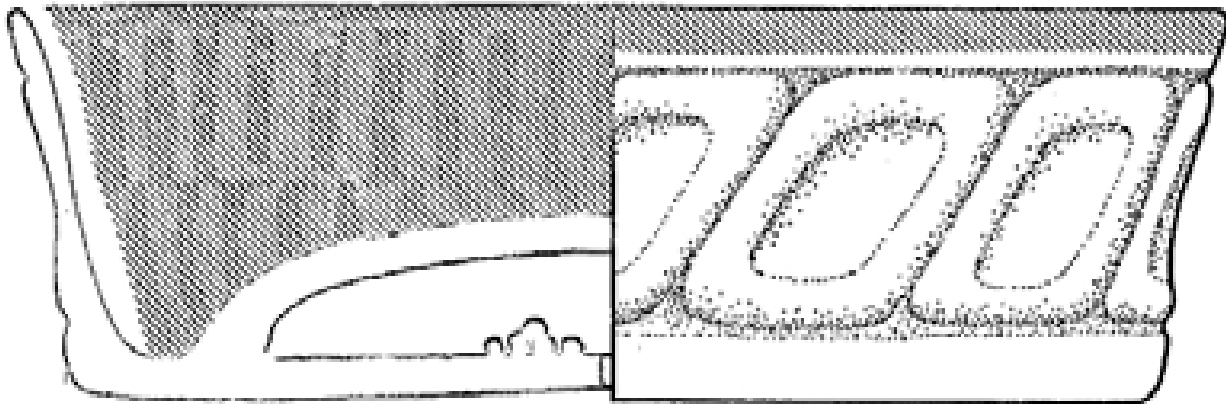

Fig. 44 Orange rattle-bowl, 117A-3³/₃₆ B.196

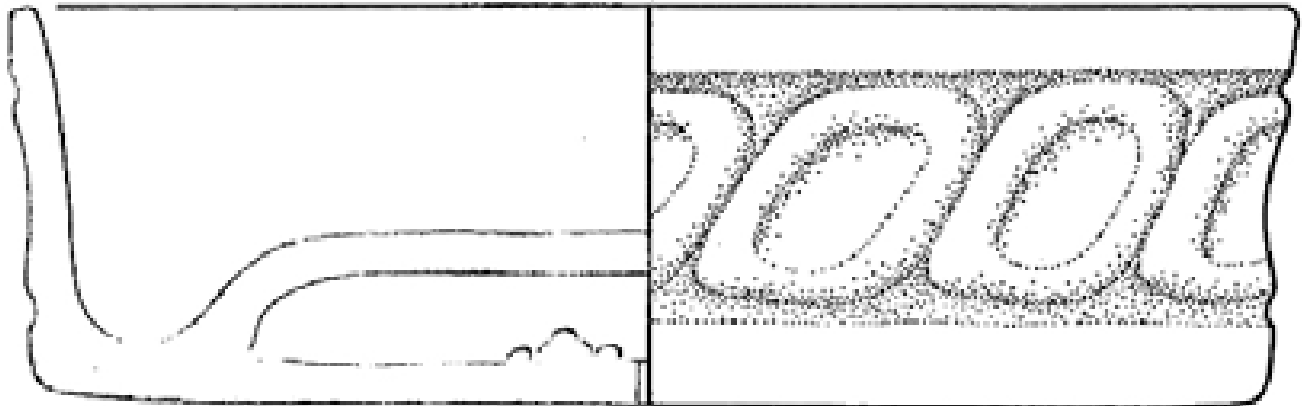

Fig. 45 Black rattle-bowl, 117A-35



Photo 60 Orange rattle-bowl, 117A-34.



Photo 61 Black rattle-bowl, 117A-35

stripe pattern radiating from the center. Its colors are red: 10R-4/10 to 2.5YR-5/10. The bowl is 8 cm. high with a diameter of 24 cm.

Black Battle-bowl 117A-35 Fig. 45 Photo 61

There appeared to have been no food in the black bowl because, when the orange rattle-bowl above was removed, there were no powdery food remains anywhere to be found. Found in perfect condition, this vessel is a low, flat-bottomed bowl with nearly straight sides; it is slipped and polished black. The exterior walls have a variant of a twisted rope design. Its interior base is raised and has a cavity which is filled with small pellets of some kind. There is a small hole, .3 cm. in diameter in the exterior base. The bowl itself is 5.2 cm. high and 17 cm. wide at the rim.

Orange Rattle-bowl 117A-34 Fig. 44 Photo 60

Just as with its black counterpart, there did not seem to have been any food in the orange rattle bowl; part of the bottom was clean and shiny when the two small black bowls over it were removed. The vessel was intact and still highly polished, and fit right in the black rattle-bowl.

The vessel is a low, flat-bottomed bowl with very slightly flaring sides. The interior base is convex, with a hollow space inside filled with pellets of some kind. The same twisted rope design as on 117A-35 rings the exterior.

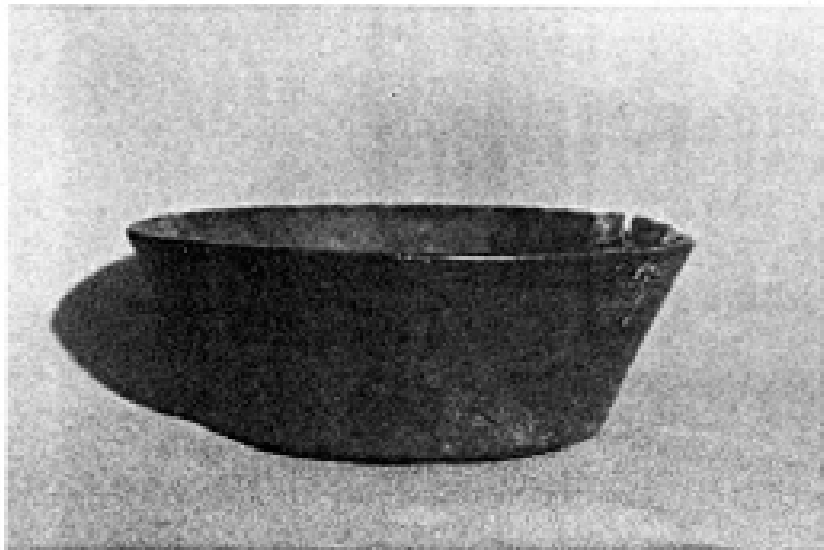

Photo 62A 117A-30



Photo 62B 117A-30



Photo 63 117A-29.

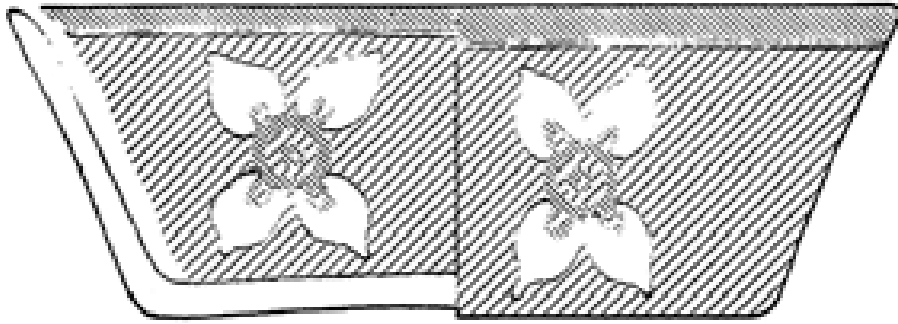

Fig. 46 117A-30

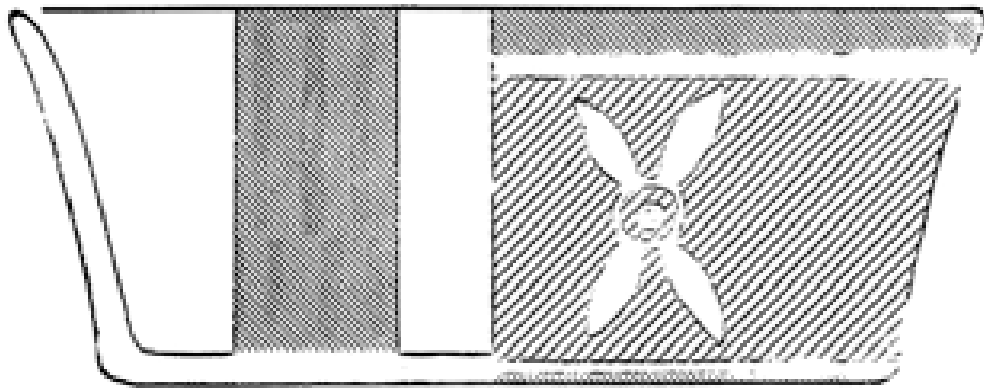

Fig. 47A 117A-29

117A-29

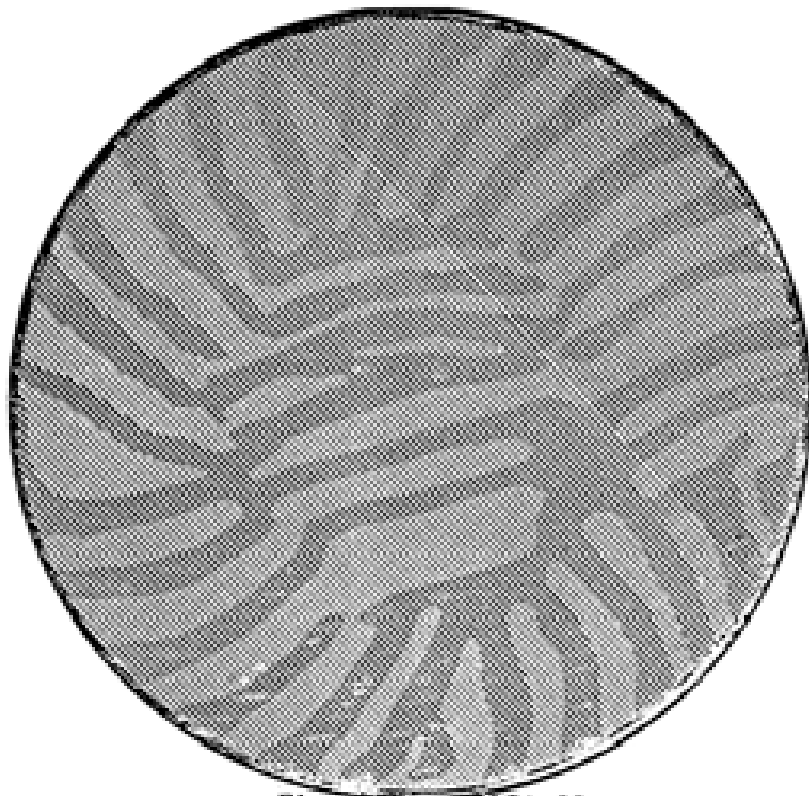

Fig. 47B 117A-29

The exterior walls are slipped orange and polished as is the exterior base. There is a red band on the exterior rim, and .4 cm. on the interior. The interior has red-on-red stripes; two vertical rows on walls and central patch, and radiating stripes on the base. There is a hole .35 cm. diameter in the exterior base. The bowl is 5.2 cm. in height and has a rim diameter of 16 cm. The Munsell colors are: red, 10R-4/10, orange, 2.5YR-6/10.

Polychrome bowl with Quatrefoil Design 117A-30 Fig. 47a, b
Photo 63

This bowl was tilted upside down over the sides of the two rattle-bowls. Its position is best seen by looking at the photograph (Photo 58). It is difficult to ascertain the vessel's original position which was probably upside down over the little black bowl that lay in the orange rattle-bowl. The relative position of the two small fluted bowls is unknown.

The vessel has a flat bottom and slightly flaring sides, all of buff paste. The entire vessel is slipped and polished. On the exterior there is a red rim band .9 cm. with a black band .3 cm. at the base. The interior sports red-on-red stripes, two rows of vertical ones on the walls. There is a central patch with pinwheel designs on both the interior and exterior base. There are four quatrefoils on the exterior sides (?), each with two concentric circles in the center.

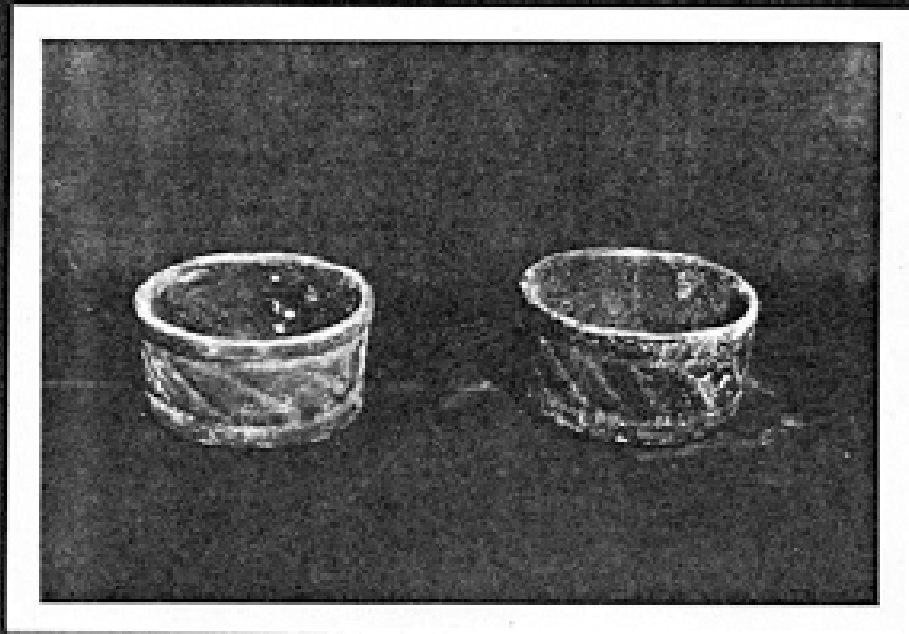
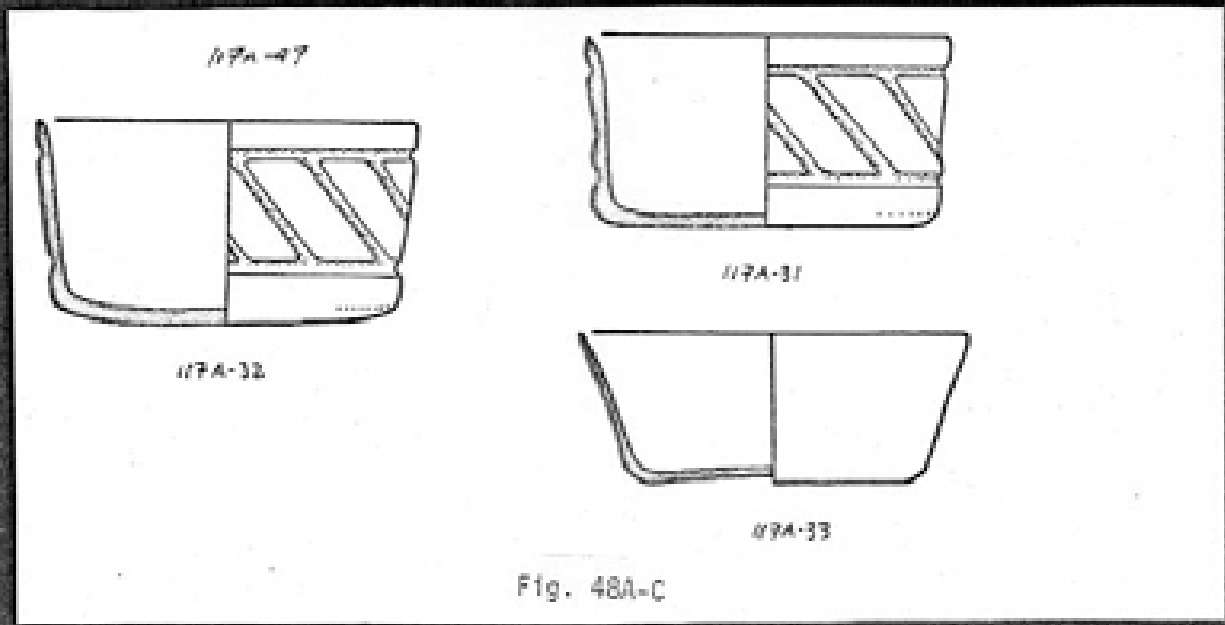

Photo 64 Small black fluted bowls, 117A-32, 117A-31.



The bowl has a height of 6 cm. and a diameter of 15.5 cm. The colors are: red, 10R-4/10; orange, 2.5YR-6/10.

Another vessel with quatrefoil designs was found in another part of the aisle. The photographs have been included here for comparative purposes although the description of the second vessel is on p. 149.

Small Black Fluted Bowl 117A-32 Fig. 48a Photo 64b

This vessel was sitting in the tilted, black flat-bottomed bowl, and both lay within the orange rattle-bowl. Exactly how they ended up in this position is not known, because 117A-32 does not touch the base of the orange bowl. It appears that 117A-33 was forced into its position by the collapsing wall. There were slight traces of a brown powder in the bottom of 117A-32 which suggested food traces, but not enough was found to be convincing.

This small bowl has a slightly convex base and almost straight sides. The entire vessel is slipped and polished black. Pre-slip, pre-polish grooves occur ca. 1 cm. from the base and rim between which there are diagonal grooves ca. 1.7 cm. apart. The bowl is 6 cm. high with a rim diameter of 10.7 cm.

Small Black Flat-bottomed Bowl 117A-33 Fig. 48c Photo 72

This small plain black bowl was lying on one side with

its mouth approximately towards the bench. Its exact original position is unknown.

The sides of the bowl flare slightly, and the entire vessel is slipped and polished black; it is of a 4.1 cm. height with a rim diameter of 10.7 cm.

Small Black Fluted Bowl 117A-31 Fig. 48b Photo 64a

This bowl is almost identical to the other one in the pile, 117A-32. It is not actually on the pile but lies off to one side. Its exact, original placement is not known.

Its base is slightly convex and the sides are almost straight. The entire vessel is slipped and polished black with blotches of red-brown. There are pre-slip, pre-polish grooves ca. 1 cm. from the rim and 1.2 cm. from the base; between which are diagonal grooves 1.5 - 1.7 cm. apart. The bowl is 5.6 cm. high with a 10.4 cm. rim diameter.

Cylinder Vessel with Black-on-red Spiral Decoration Plan #30
117A-25 Fig. 48d. Photo 65

A small cylinder with a slightly convex base and slightly concave walls (which expand towards the rim) was found on the west side of the pile of bowls. This piece was of buff paste with its exterior base unslipped and unpolished; its exterior was red slipped with bands of black 1.3 cm. below the rim and at the base. Between these bands a connecting band of black, ca. .9 - 1 cm. wide, spirals around the

cylinder. The interior is interesting, with red down to 1.8 cm., then .2 cm. of black and the remainder black; all slipped and polished. The red is generally close to 10R-4/10, but some is closer to 2.5YR-5/10; the orange is ca. 2.5YR-6/10. This cylinder, 11.3 cm. high with a rim diameter of ca. 8.4 cm., is similar to one from Bu. 116.

FLAT-BOTTOMED CYLINDERS WITH INCISED PANELS

The largest group of vessels was one of 13 stucco-covered cylinders; 11 were lined up against the north wall and two were near the west end of this row near the bench. As 13 was a symbolic number for the Mayans--it was the number of the levels of their heaven--there may be a significance to the group of 13 pots. The characteristic feature of these containers is a rectangular panel in which there is incised the face of a deity. There are two panels per pot, and the faces in the two panels are always meant to be identical on the same vessel. Each panel is outlined by a deep groove; the top and bottom grooves bounding the panels carry all around the pot. The space in between on each side usually has a vertical groove dividing it; but in some cases, this dividing line was later filled in with the stucco that covered most of the non-incised portion of the vessel. Below the rim of all vessels is a band with possibly glyphic elements deeply incised. The elements in this band vary from vessel to vessel.

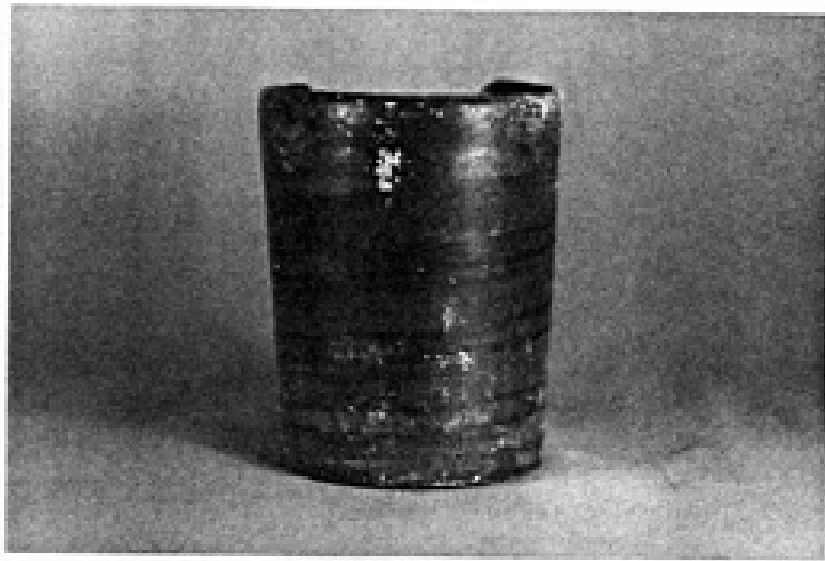
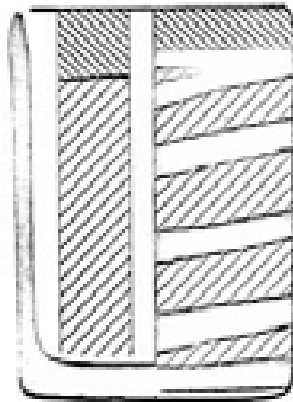

Photo 65 Cylinder with black spiral design, 117A-25.



117A-25

Fig. 48D

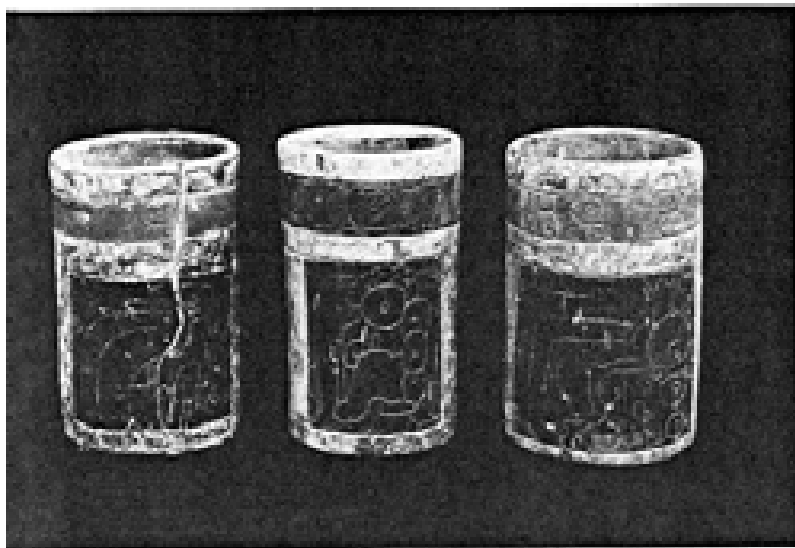

Photo 66 117A-13, 117A-6, 117A-4.

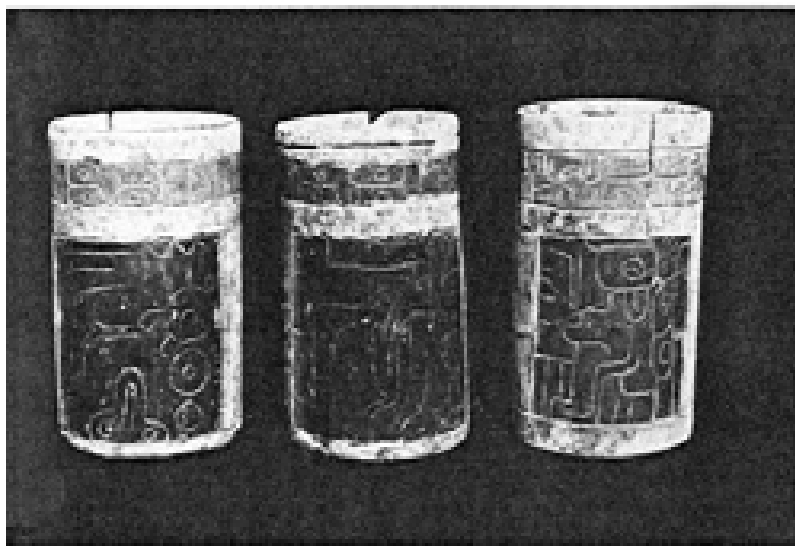

Photo 67 117A-10, 117A-9, 117A-5.

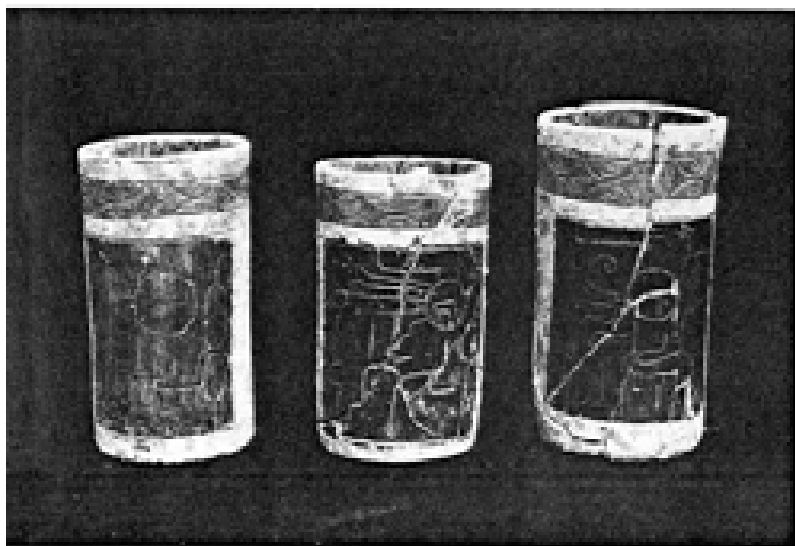

Photo 68 117A-15, 117A-16, 117A-7.



Photo 69 117A-8, 117A-12, 117A-11.

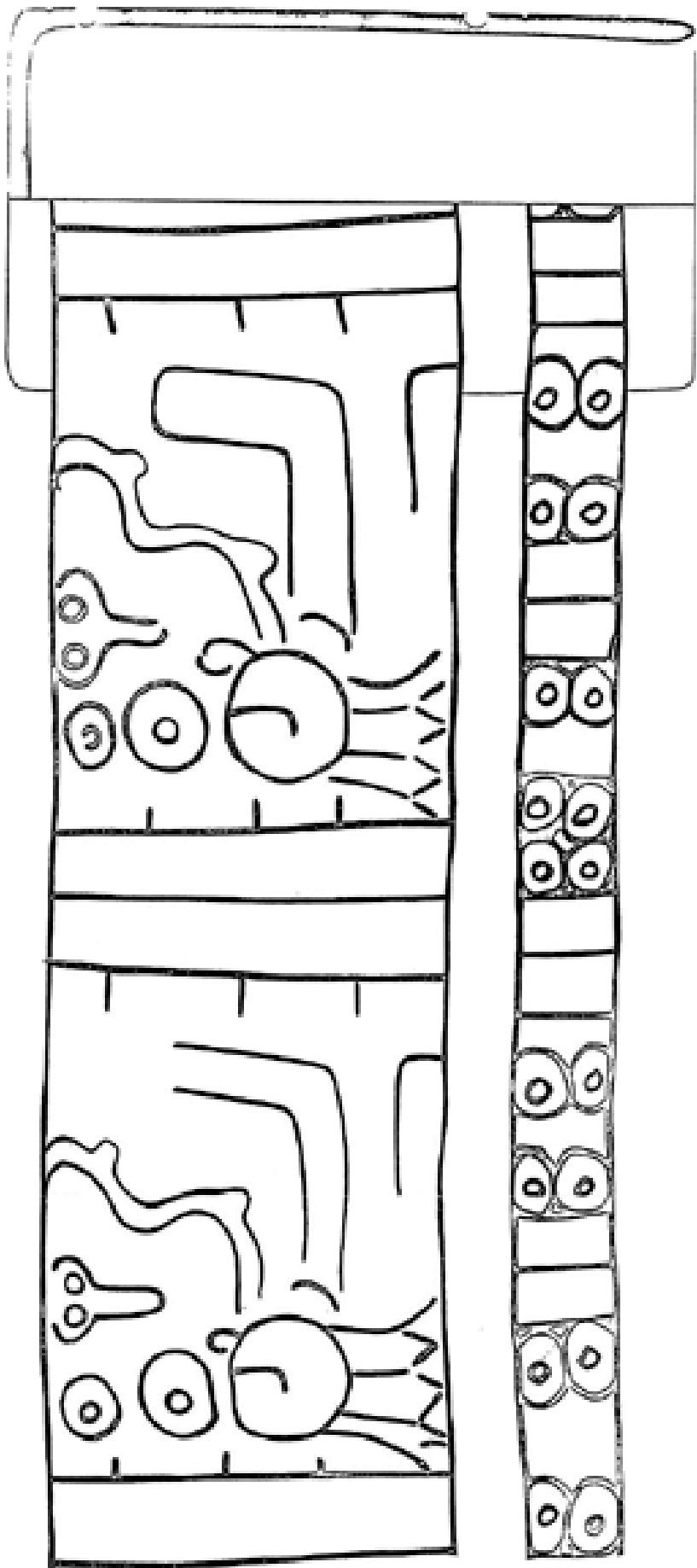

Fig. 50 11284

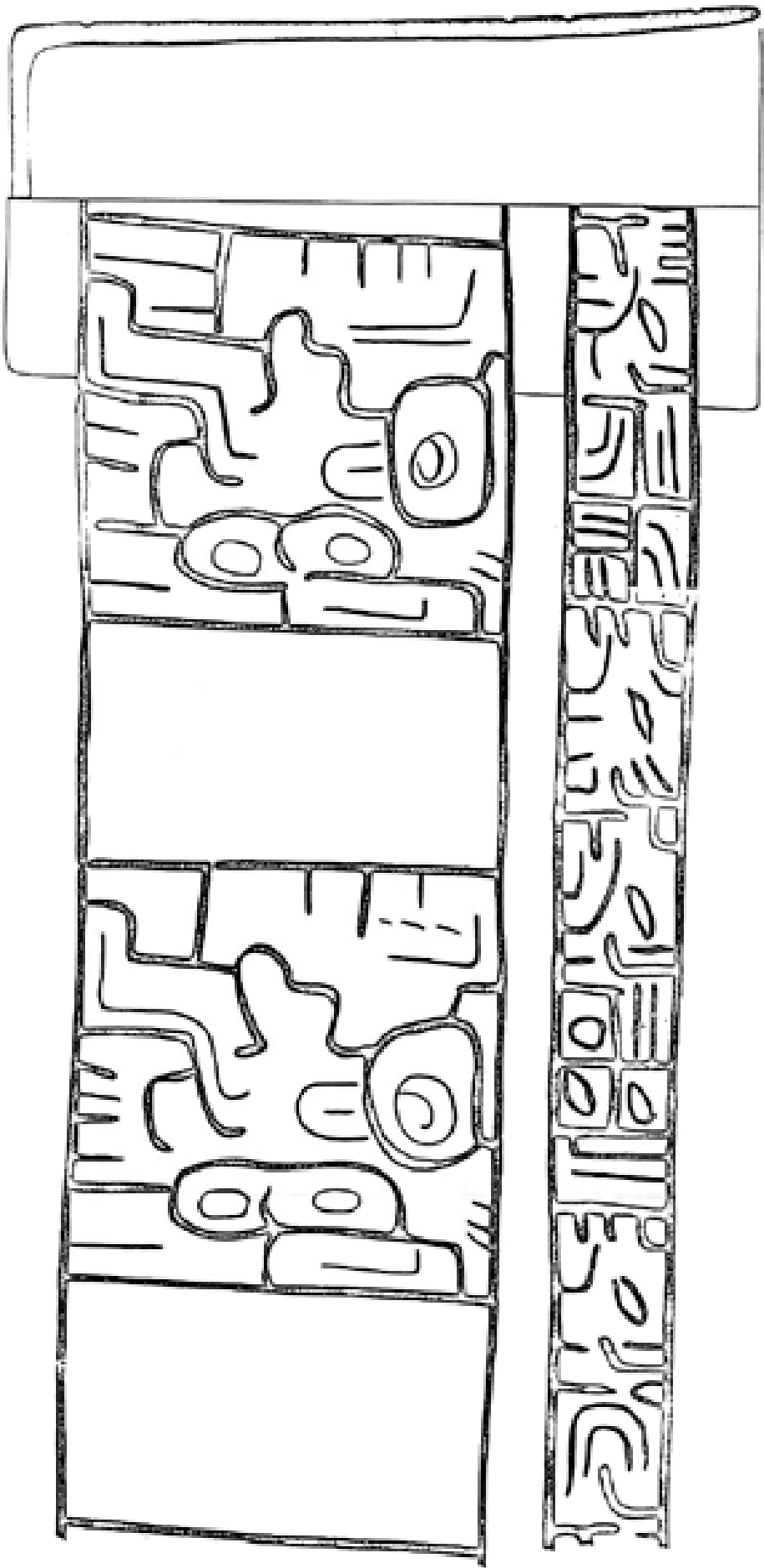

Fig. 31 1870-3

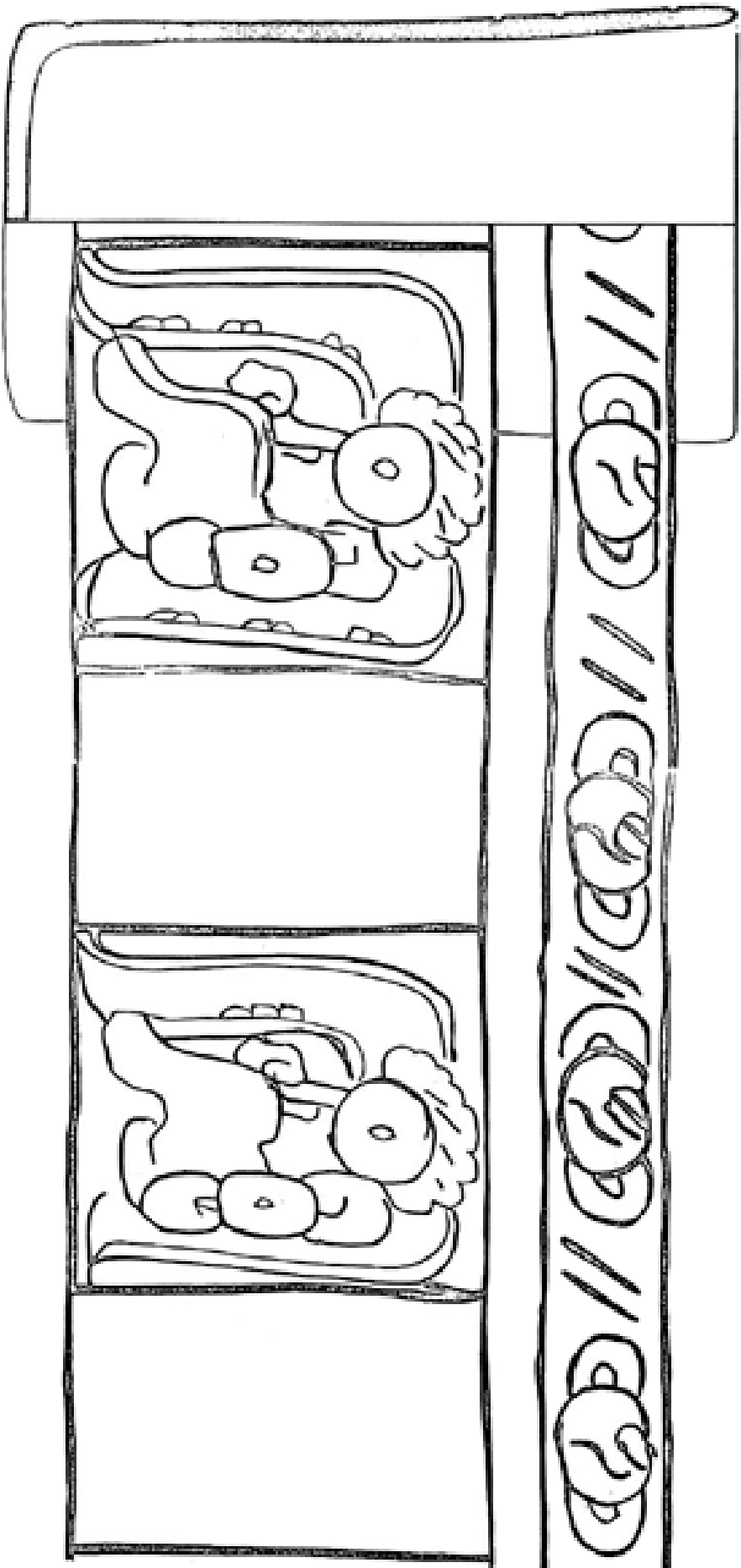

Fig. 52 11264

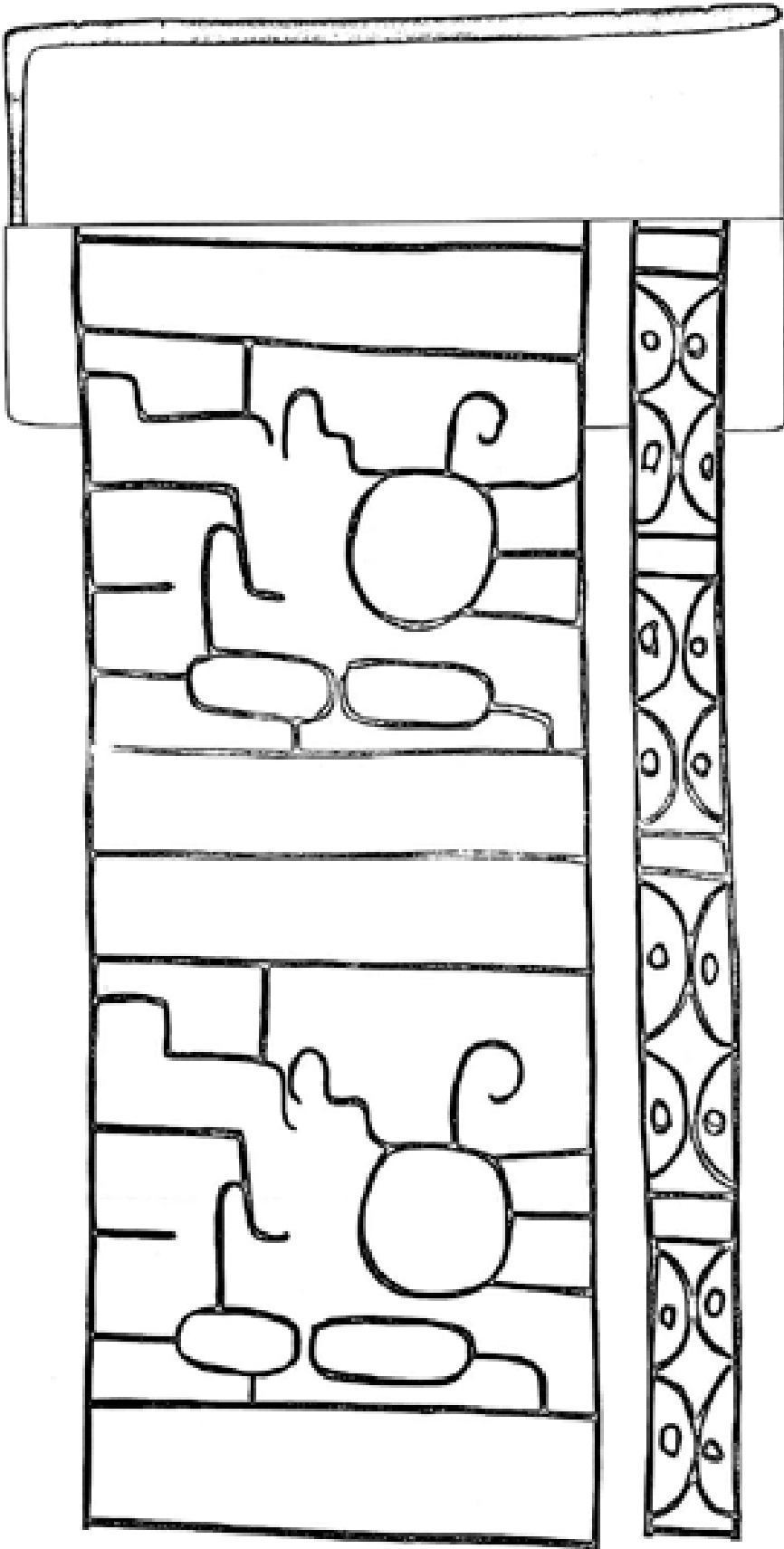

Fig. 53 1126-2

1924-7/36 B.M.G.

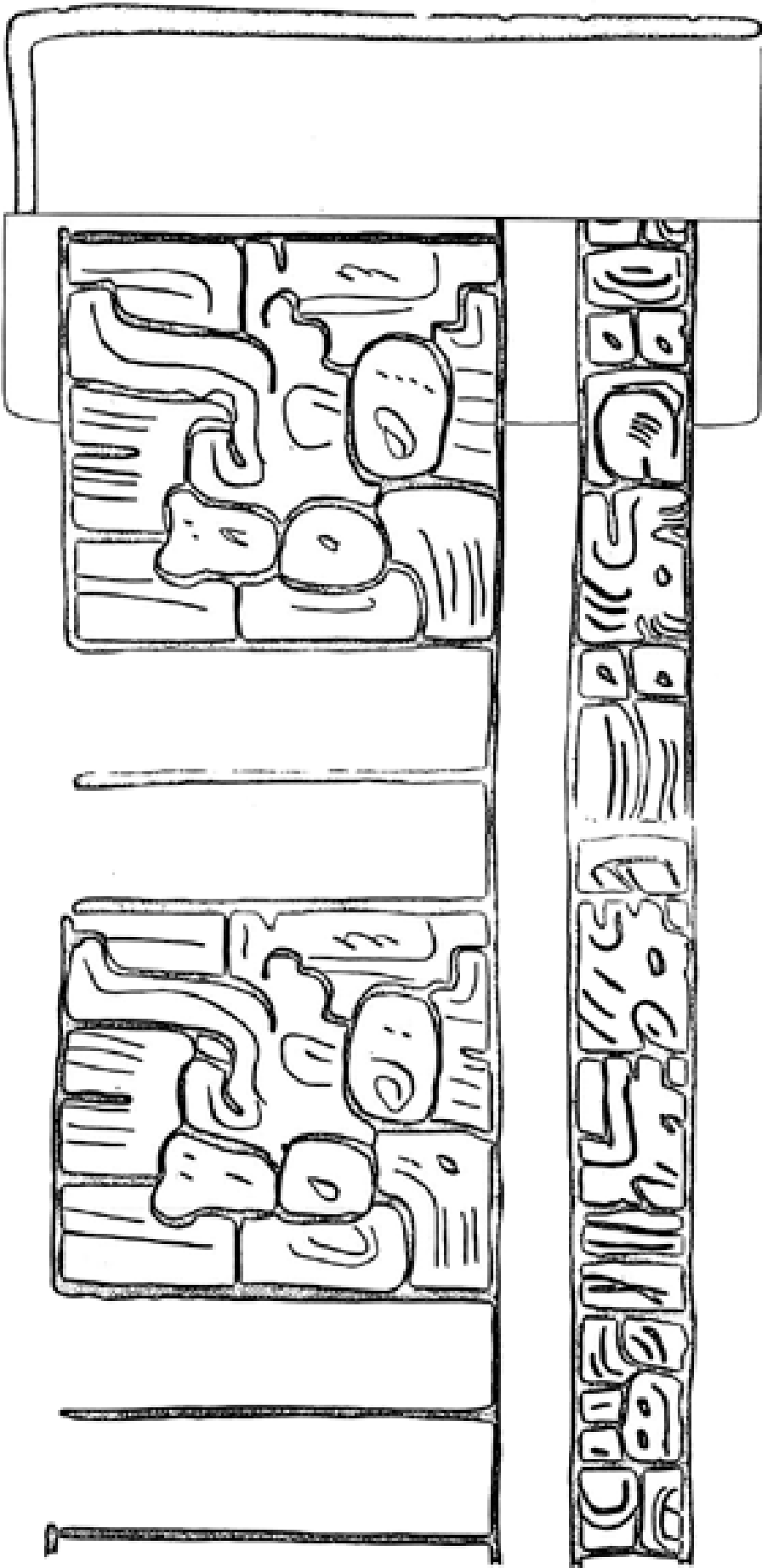

FIG. 54 112A-B

112A-B/30 8.95

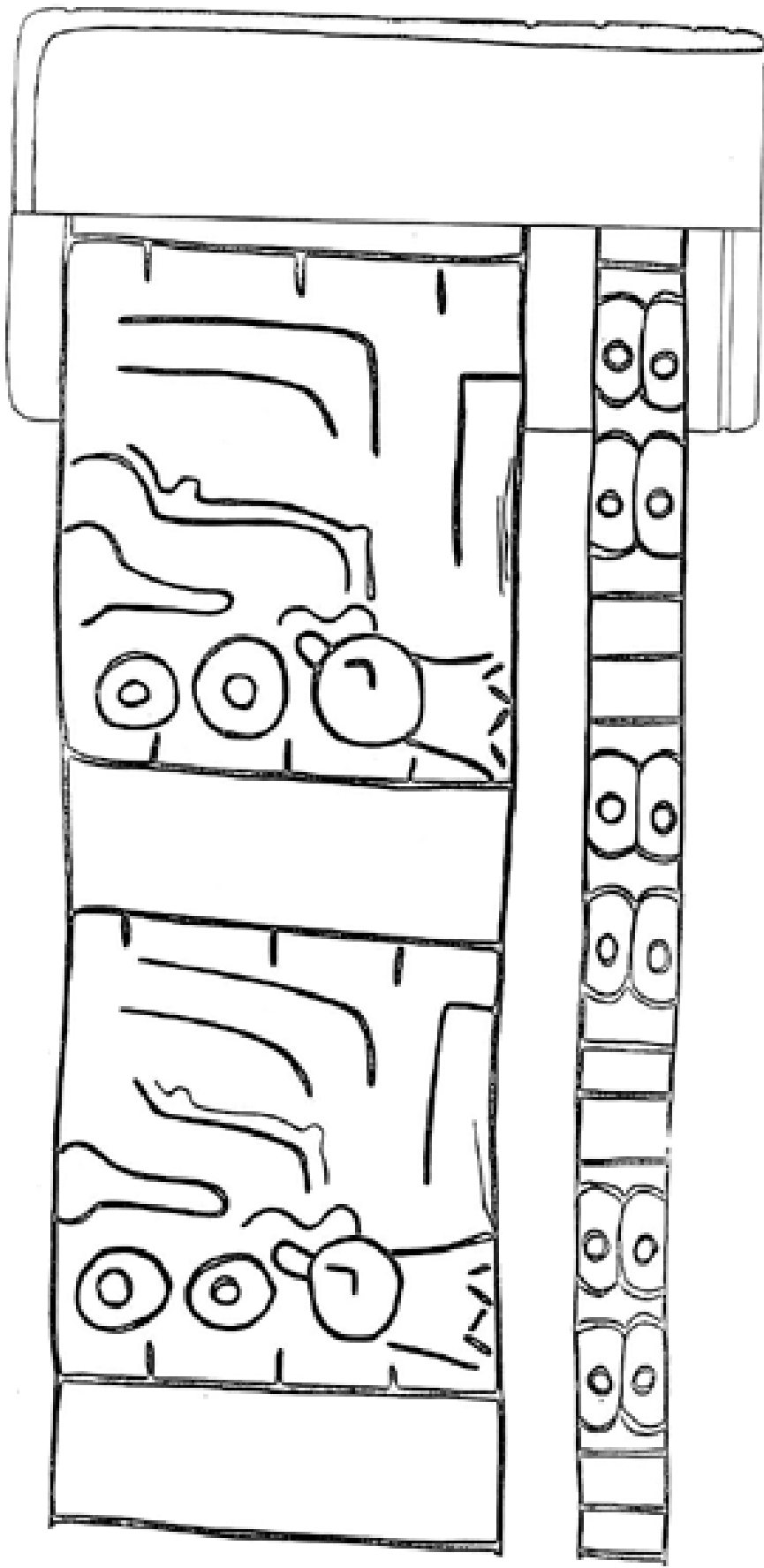

Fig. 55 1124-9

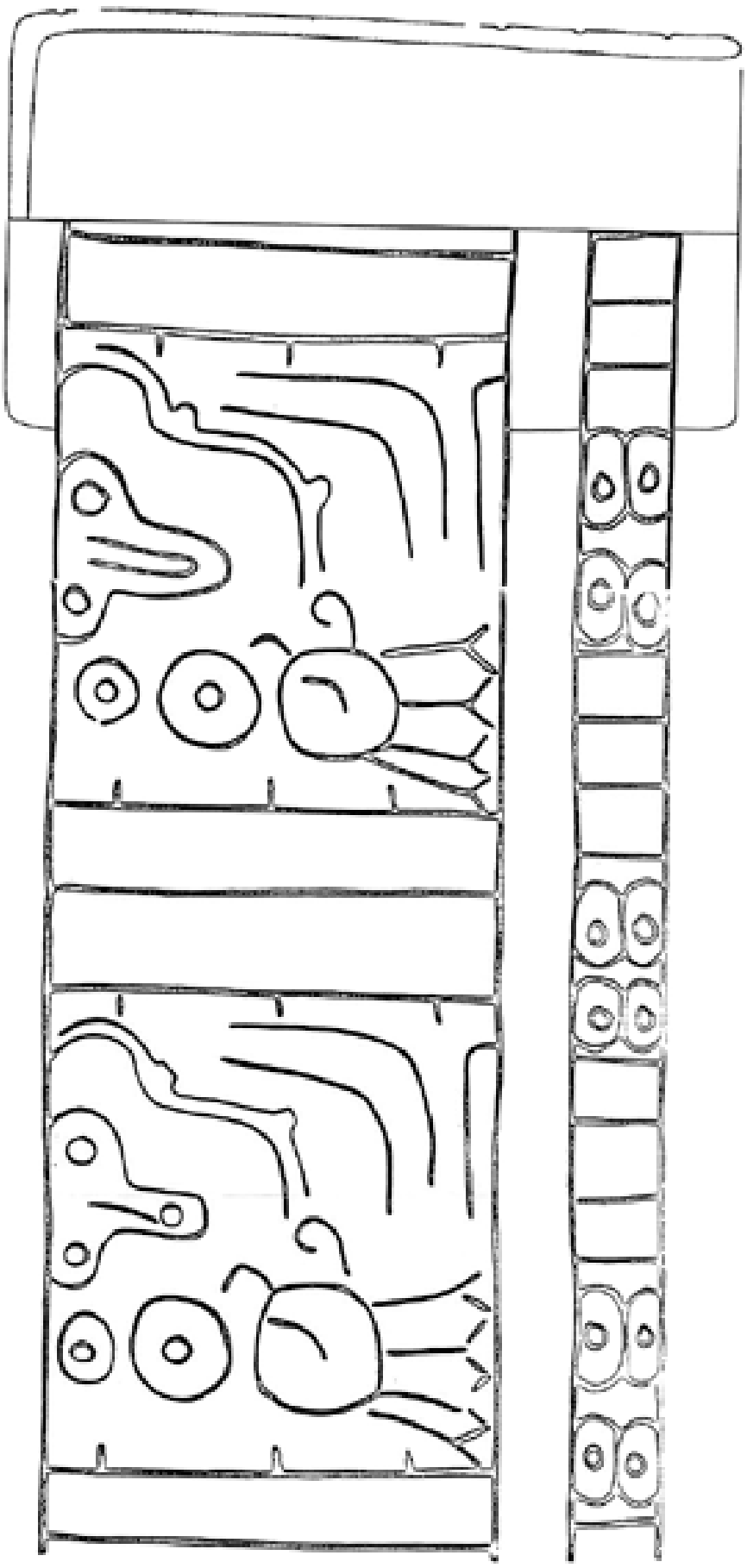
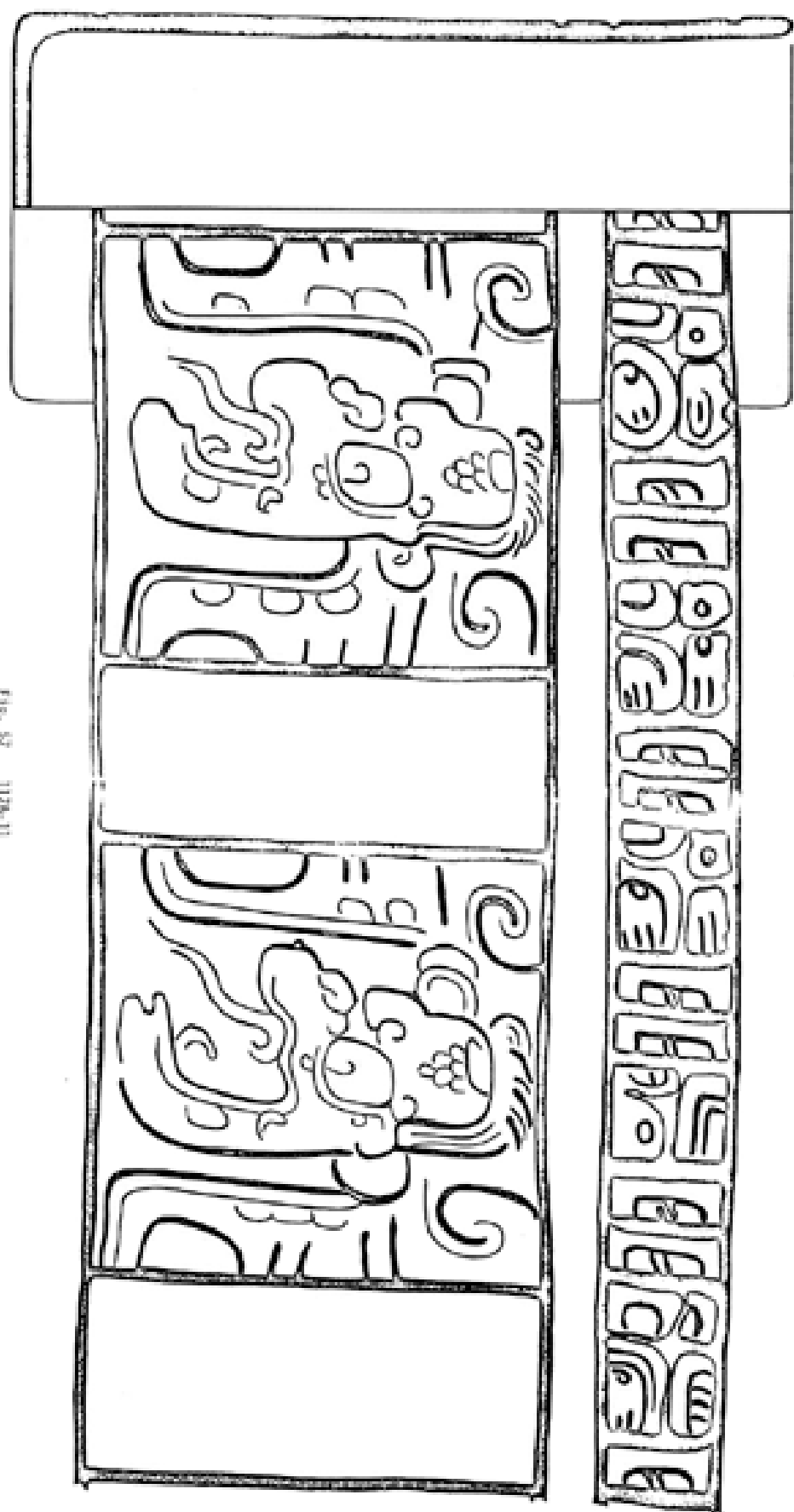

Fig. 55 1134-15

Fig. 57 1126-11



1940/100 0.194

FIG. 58 1136-12

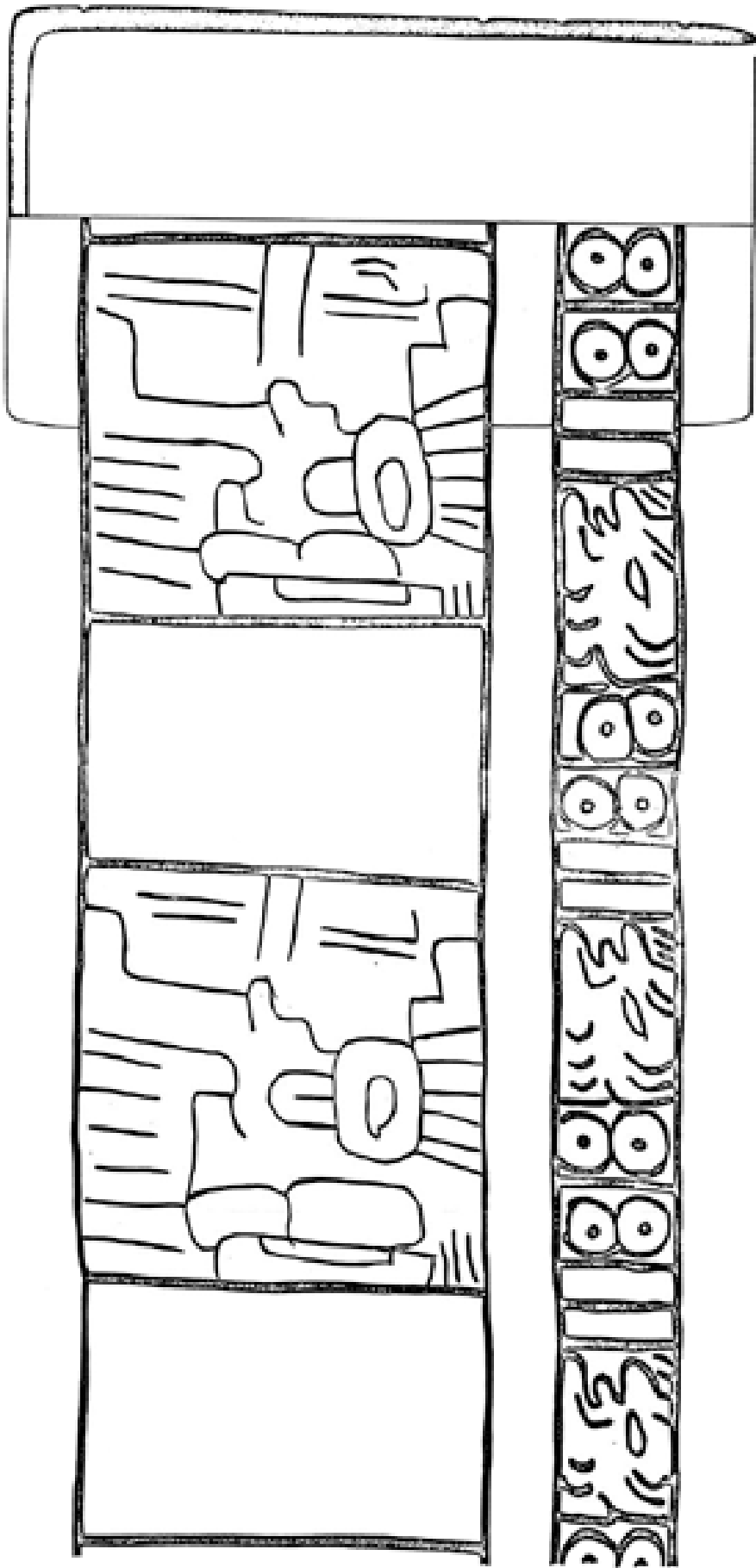

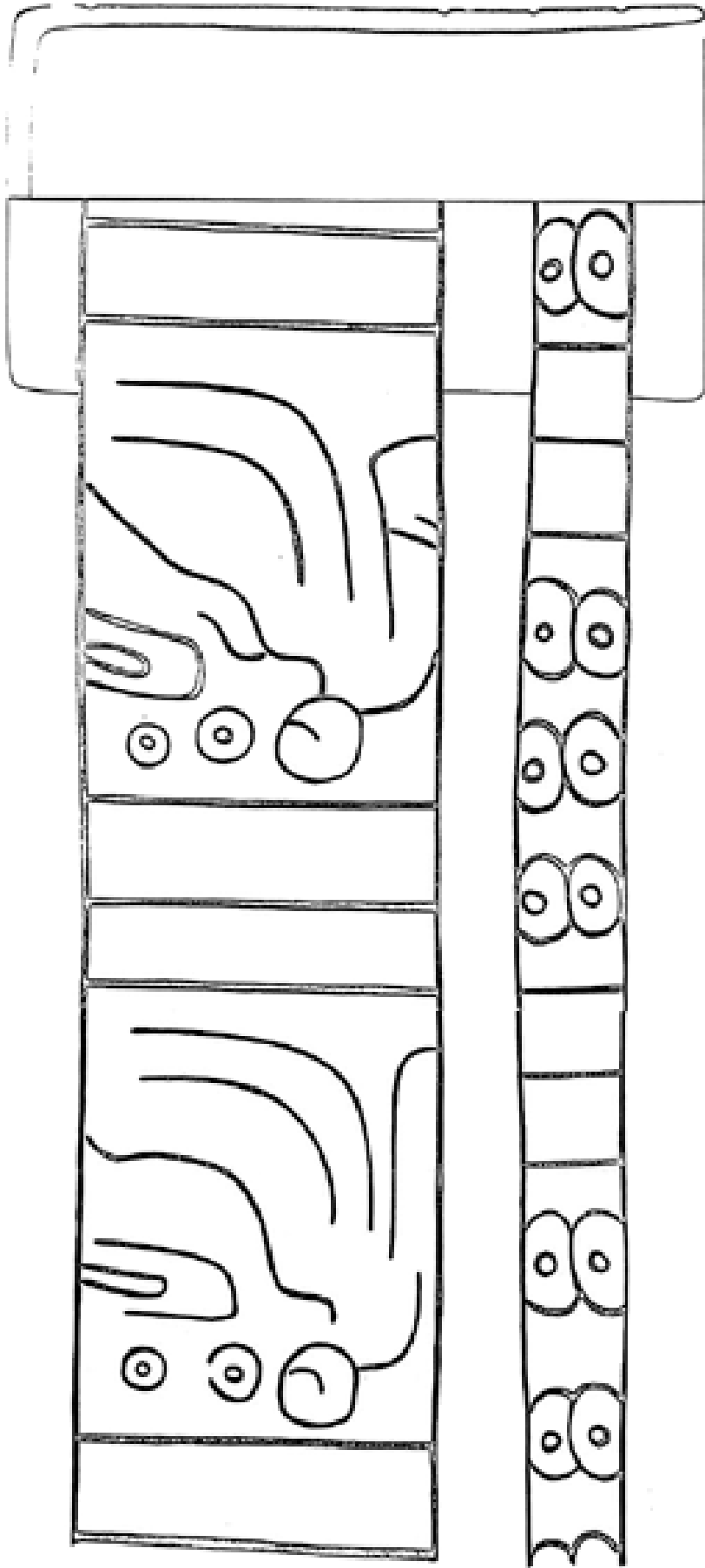

Fig. 59 100-10

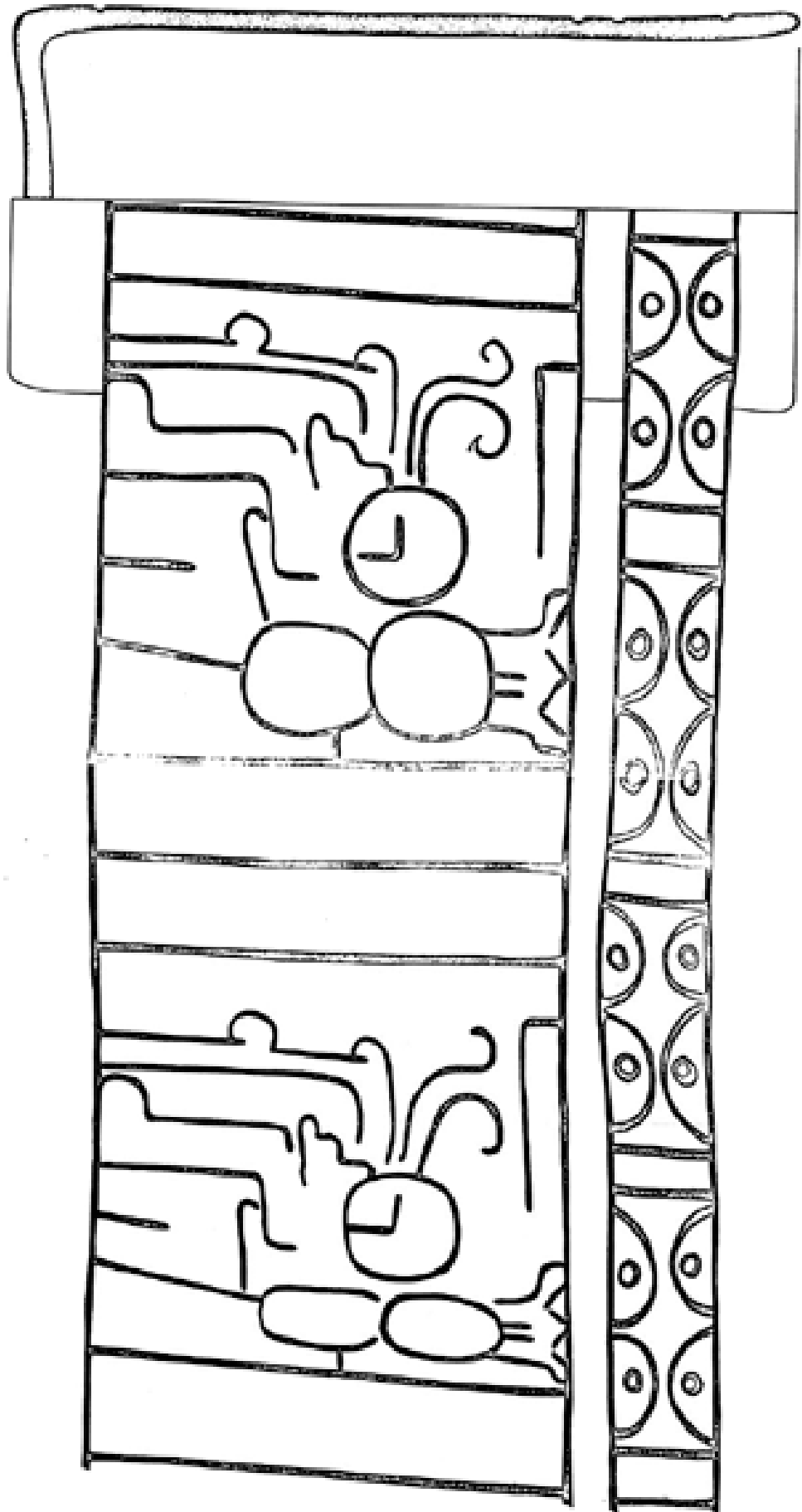

Fig. 60 1178-14

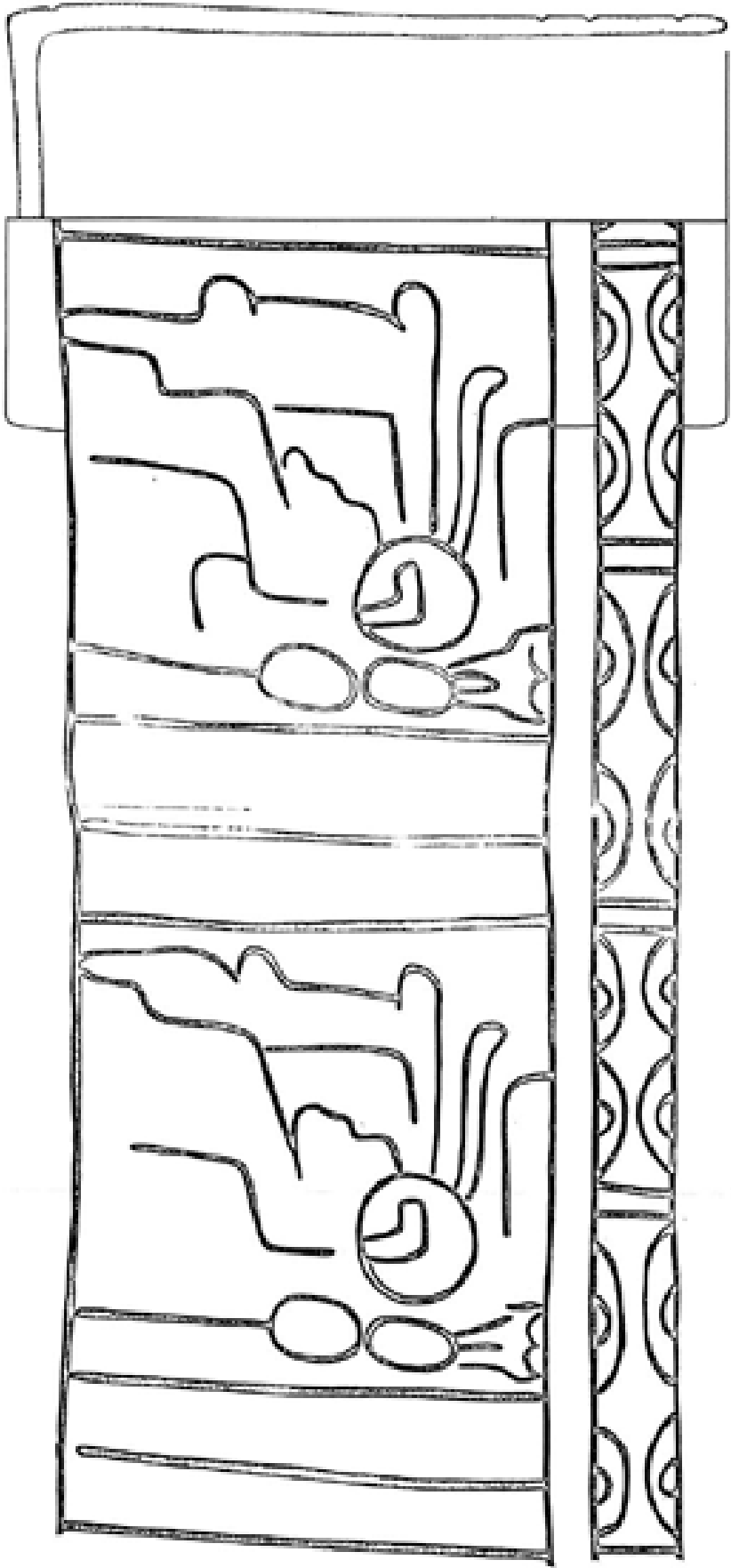
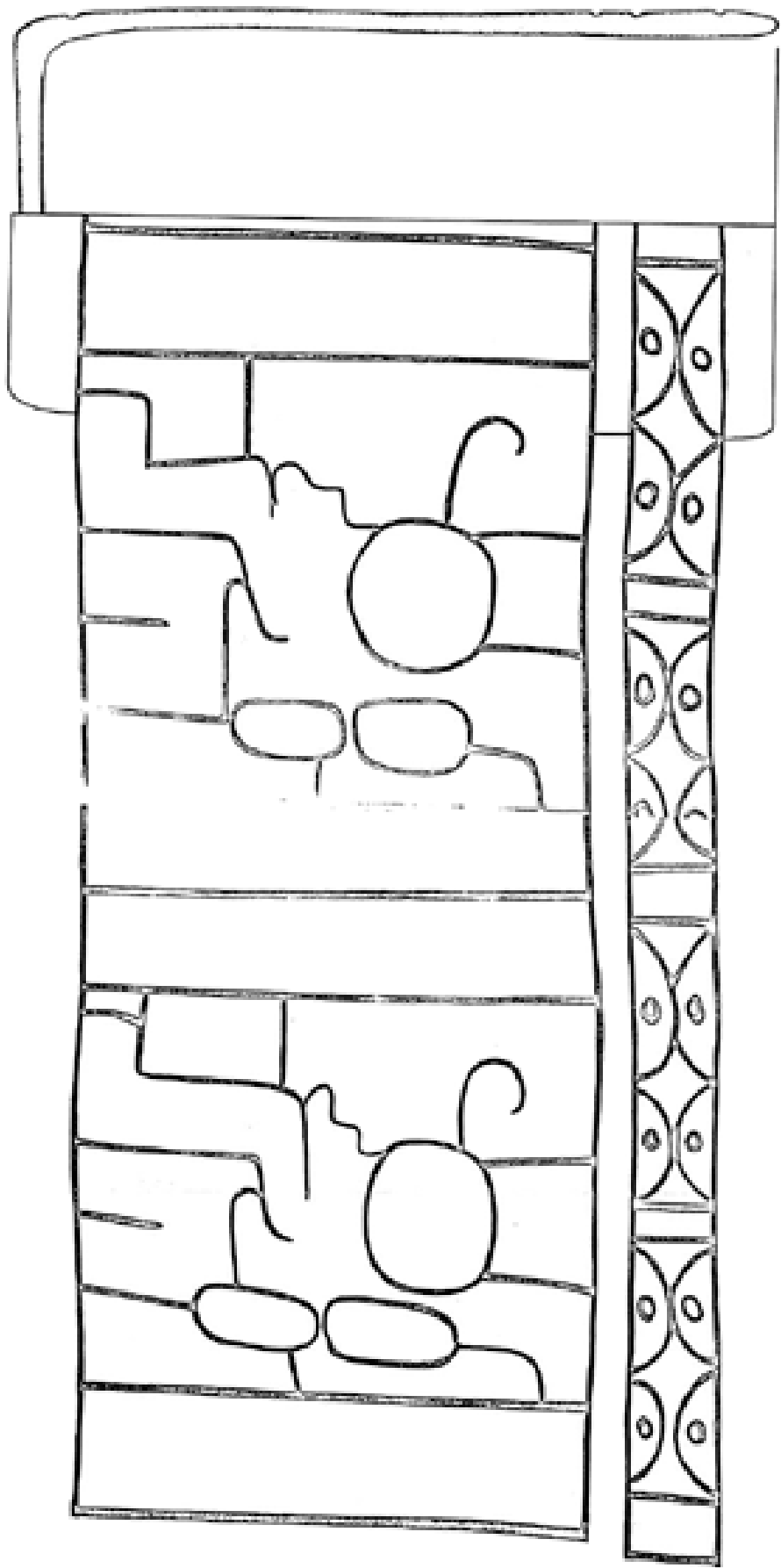
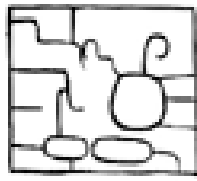
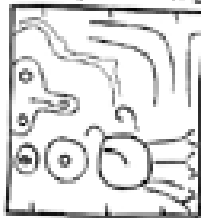
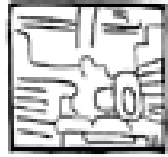
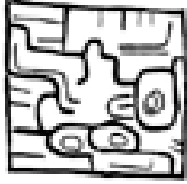

Fig. 62 312A-15



174-0/36 B196

Fig. 61 128-15



The panels are covered with brownish-black paint, giving the effect of varnished or stained wood, the paint usually being post-incision and not always reaching to the edges of the panel--almost none of the vessels are a good example of neatness. The exterior sides of the vessel, excluding the panels and band, are covered with a light bluish green stucco, almost white. In general, the exterior base was unslipped and unpolished, although in one case it was painted red (117A-14). The interior walls were painted brownish-black down to a depth of around 5 to 6 cm.

Most of the vessels were cracked, smashed, warped, or all three. Although in the photograph showing them in situ (Photo 70) they appear to be in good condition, many are fractured and held together only by collapsed fill in and around them. In the bottoms of the vessels was up to 2 cm. of brown or golden decayed matter in a powdery form. In one vessel (117A-14) there was no powder but the impression of what could have been seeds on the bottom of the wall debris that had fallen into the vessel. All vessels, except one, had their panels lined up north-south. Sandwiched between some of the cylinders at the west end of the row is a vessel (117A-28) on its side. How it got into this position is unknown (see p. 151).

Fig. 49 shows the positions and catalog numbers of the 13 vessels. For convenience's sake the description will be

according to the sequence of catalog numbers assigned in the lab.

As can be seen, none of the designs is identical to more than one of the others, and of these there are only two pairs: 117A-7 with 117A-15 and 117A-10 with 117A-4.

There are three deities represented but it is possible that the three types are really varieties of the same long-snouted deity. The first type will be called Type A, to which all except 117A-6 and -11 belong. Both of these two deities are sufficiently different from the others to be types in themselves.

There is an interesting progression toward simplification of the faces of Type A (Type A is best exemplified by 117A-8) (Fig. 54).

The most important distinguishing feature of the face is the drooping upper lip or nose. That it is an upper lip is suggested (on 117A-8 and 4P-2, Figs. 55 and 64) by the interior line which continues from what is clearly the lower lip or jaw. It may, however, be a nose because the scroll element on 4P-2 occurs only on noses and the rest of the face is that of the Long-nosed deity. Miss Proskouriakoff believes it to be a nose, Dr. M. Coe thinks it is an upper lip. Until the author has made a more thorough study of the Long-nosed god his conclusion is that although it looks most like a lip, artistically it may have been meant to represent a nose.

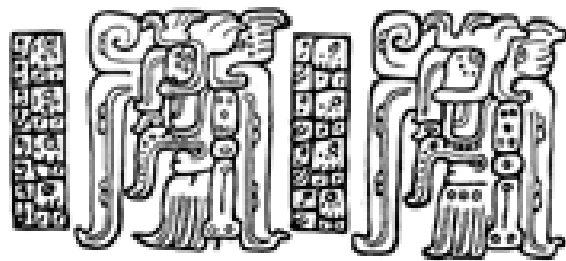

PANEL 1

FIG. 1

PANEL 2

FIG. 2

The gradual simplification of the faces is evident, beginning with 117A-8 (The design on this vessel is clearly derived from the prototype design on a cylinder from Bu. 116, Temple I: 4P-2, and the 4P-2 design is clearly related to the long-nosed god) (see p.144). The sequence then runs: 4P-2, 117A-8, 117A-5, 117A-12. Here there is a slight break and a new element (forked element over earplug) is introduced. 117A-7 and -15 are in a curious position. They possess a scroll originating from the eye which links them to the 117A-14 series yet they lack the uppermost headdress element (a projection forward which is a trademark of the long-nosed god). 117A-7, -15 are not in direct connection with the 117A-8, 5, 12 series because there is at least one missing link.

A sub-series, 117A-14, -16, -10, -4, -9, and -13, had 117A-14 to clearly relate it to the 117A-8 series. The feature that separates this series is the forked element over the earplug, which is present in a subdued and conventionalized form in the 117A-8 series. This element is derived from a water lily.

Derivation of the Design on 117A-8 from that on 4P-2

Bu. 116 contained one stuccoed, incised cylinder that was similar to the 13 found in Bu. 196. Their direct relation will here be gone into in detail.

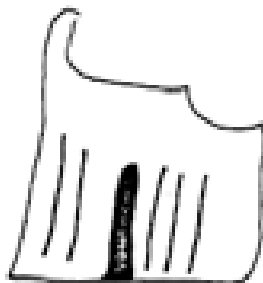
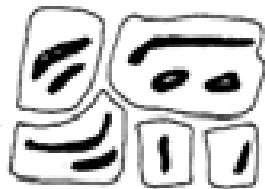

The Glyph Band

On 4P-2, instead of a horizontal glyph band there are two vertical ones, one in front of each one of the deity faces. Panel 1 has two possible inverted Ahaus over two Imix glyphs; although it is probable that all four are meant to be Imix. The second panel has four Imix glyphs.

On the 117A-8 glyph band there is only one element that is similar to an element on the 4P-2 panels, and that is what may be a simplified, inverted ahau (Fig. 64). The other element on the band that has been identified is a Zotz glyph. Except for the method of execution, there is not much to link the designs of the two vessels on the basis of glyphs alone.

The Head: The Headdress

The headdress of the deity on 4P-2 consists of the following parts: a floral element on the left; an element in the upper center; a glyph inset; and forward-flowing elements. The outline and interior lines suggest a water lily is meant by the right element. The lines, circle and dots of a headdress element in a corresponding position on the 117A-8 headdress suggests that the same concept was being portrayed (Fig. 65d). The thin, approximately horizontal lines and the one major thick line dividing the motif in two, connect the headdress elements found on the upper center of the two deities (Fig. 65e). For the glyph inset, the similarity is expressed by

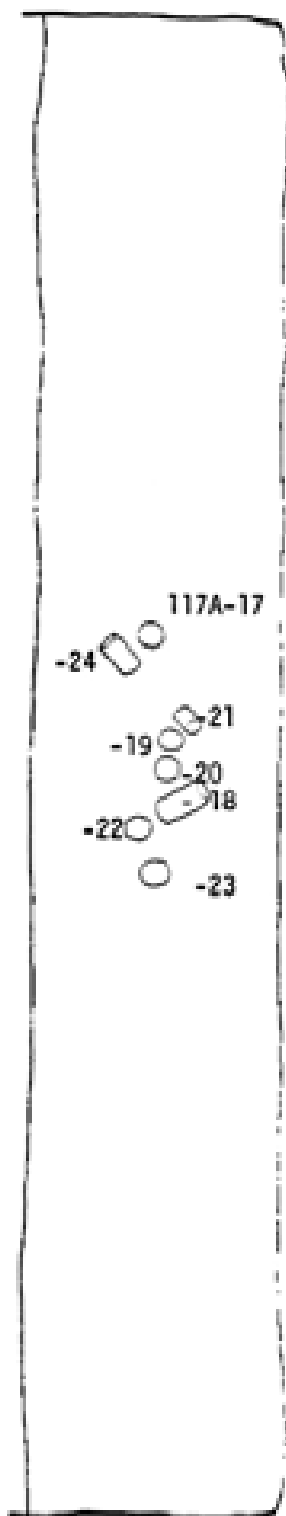

Fig. 67 Detail plan showing the location of the black cylinders.



Photo 70 Black cylinders on the floor, as found.

dots present on both, and on the attempted concentric circles on 117A-8. For the downward flowing frontal headdress element there is no correspondence between the two vessels. Except for the two non-Type A faces, none of the more complex faces have a downward flowing design.

Thus, for three out of the four elements there is an obvious derivation of the 117A-8 motifs from those of 4P-2. For the fourth feature, 117A-14, -16, -10, -4, -9, and -13 all possess it but not 117A-8. Incidentally, these six cylinders all have relatively long panels to accommodate this element. In 117A-8 the feature may have been dropped to provide an upright rectangular panel.

The Head: The Face

Except for the nose and somewhat for the eye, for facial features there is a direct correlation between the two faces, especially in the line bisecting the length of the upper and lower lips, and the beard. The 4P-2 face has the nose scroll of the long-nosed god; an important feature not found on the 117A-8 or -14 series.

Summary

On the basis of technique and iconography it should be obvious that 117A-8 and 4P-2 both depict the faces of the same deity.

The whole concept of a long-nosed versus a long-lipped deity is a thesis in itself, but the following elements on

the 4P-2 face identify it as a variant of the classic long-nosed god: water lily as a headdress element, nose scroll, water (Rands, 1955) flowing from forehead, beard, inverted-ahau earplug pendant, eye, and glyph inset in forehead. Each of these elements may occur on other deities, but their presence all together and their relative and non-relative positioning suggests a variant of the long-nosed god.

The Two Remaining Deities

Two of the faces in the series of incised panels are different from those of the series of the long-lipped god. One of the faces, 117A-11, has a long nose and many elements of the long-nosed god but is a variety of its own and may represent another deity entirely.

The features present which are also present in representations of long-nosed gods are: one of the cauac infixes (what looks like a bunch of grapes); the semi-circle above the cauac element which does not occur on the glyph but does when the element is used on long-nosed gods of a certain variety; the eye with a hook and circles below it; the element above the nose which is one of the features that is present on 99% of the profile representations of the long-nosed god; the double outline of the mouth which is a method of depicting a serpent and/or jaguar's mouth and is often found on the long-nosed god; the teeth that could pass for those of the long-nosed god; and there is a suppressed head-

dress bar showing in the panel, which is a characteristic almost wholly reserved for long-nosed gods. Missing on the incised panel, and present on many long-nosed gods, is a more fleshless lower jaw. Unfortunately, most of the elements present on long-nosed gods also recur on representations of other deities.

The final deity, 117A-6, appears to be some sort of bird. Its crested headdress, the blunt, droopy, upper lip, and possibly the glyph in the band above will eventually lead to an identification of this supernatural (?) being.

BLACK CYLINDRICAL VESSELS

The next group of interrelated vessels occurs about midway down the aisle. The row of cylinder pots is situated on its north; the tripod plates on its east and, along with the edge of the bench, its south; to the west there is some open space. The group consists of: a stucco-rimmed, plain, black cylinder and seven fluted vessels.

Black Stucco-rimmed Cylinder Plan #11 117A-17 Figs. 67; 68a
Photo 72a

This cylinder is of buff paste, with black slip inside and out over the entire vessel. The exterior walls and interior to ca. 6 cm. are polished. The rim has a band of white stucco, 1.9 cm. on the exterior and ca. 1.5 cm. on the interior. The stucco may have been painted green as it has

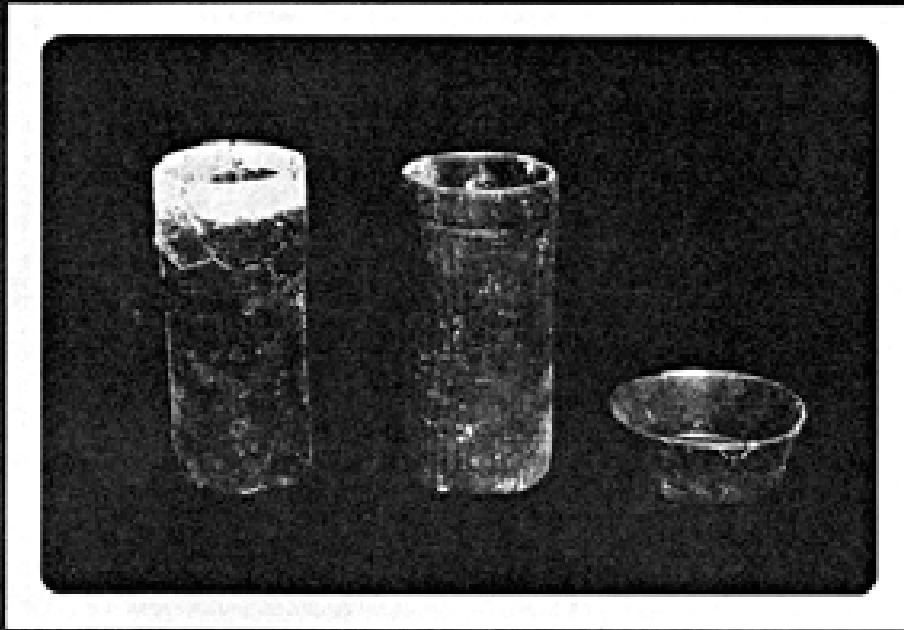

Photo 71 117A-19, 117A-20, 117A-22.

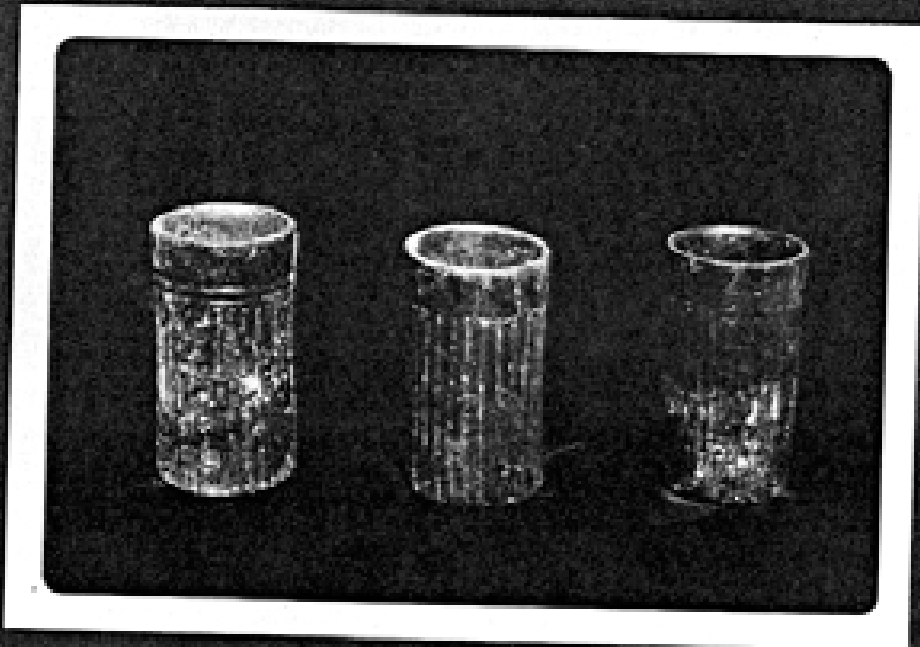
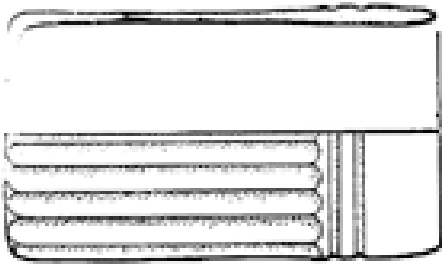

Photo 72 117A-17, 117A-18, 117A-33.

0.0001

02A-23



02A-25

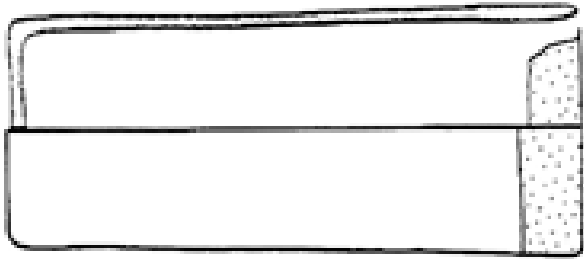

02A-24

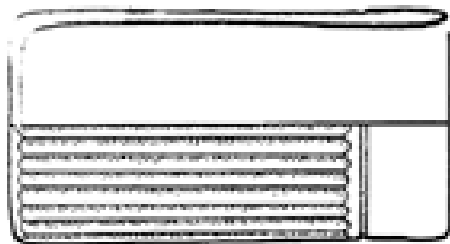

02A-28

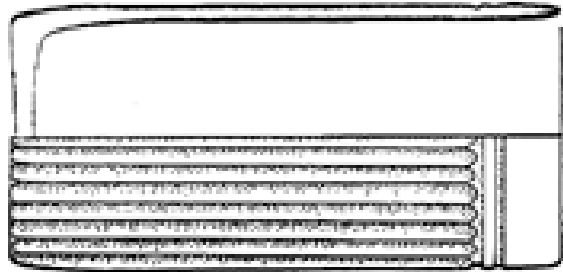

02A-24

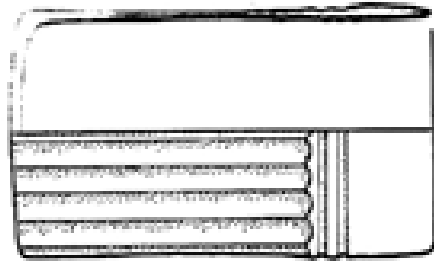

02A-27

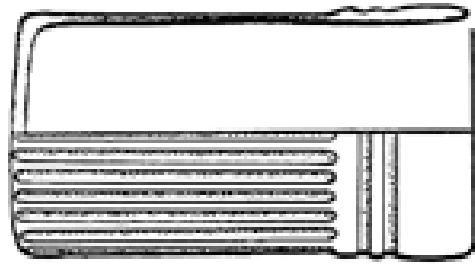

02A-29

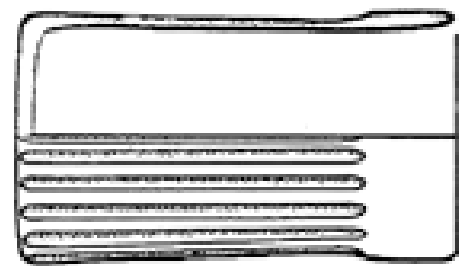

02A-29

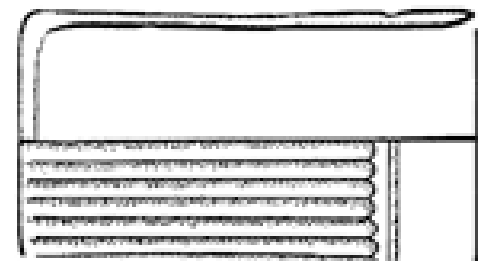

Fig. 68 Black cylinders.

a very faint greenish cast. The maximum height is 18 cm., base diameter 7.4 cm., rim diameter 7.8 cm.

Within the vessel was a thin layer of light brown dust.

FLUTED VESSELS

Vessels with a Single Vertical Groove Plans #19 23 117A-21, 117A-22 Figs. 67, e, g Photos 70, 71c

Two of the fluted vessels were similar to one another and will be discussed together. Both are characterized by the presence of a vertical groove around the pot ca. 2.5 cm. from the rim. Vertical fluting begins just below the groove and continues to near the base. Only on 117A-24 do the flutes actually continue to the base, although in the drawing the basal termination of the flutes is obscure. 117A-21 has a height of 13.9 cm., and a rim diameter of 7.4 cm.; 117A-22 has a height of 14.2 and a rim diameter of 8.1 cm. From the drawings, the slight differences in fluting may be seen.

Tall Fluted Vessel Plan #22 117A-18 Figs. 67, 68b Photo 72b

This well preserved vessel was found on its side. Still inside it, and spilled from it, was a golden brown powder, compact in the vessel itself. It is possible that this is decayed food. The vessel, with a slightly concave bottom and straight sides, has an entirely black surface.

The exterior walls and interior to ca. 2/3 down appear to have a black slip, with a glossy metallic appearance, probably partly from polish and partly from firing. There are grooves around the pot, 2.9 and 2.6 cm. from the rim. Narrow, vertical fluting runs from the second groove to the base, with only the tips of the fluting tangent to the base. The vessel is 17.3 cm. high and 8.4 cm. wide at the rim.

Fluted Cylinder Plan #18 117A-20 Figs. 67, 68d Photo 71b

In a row together were 117A-19, -20, and -21. 117A-20 is distinct in that it has no vertical grooves nor do the flutes touch. Its base is slightly convex, the sides slightly concave. The entire vessel appears to have been slipped with black which thins to reddish-brown on the interior and in spots on the exterior, with all except the interior base appearing to have been polished. Vertical fluting runs from 2.6 cm. below the rim to the base, but not past it.

Double Grooved Fluted Cylinders

Plan #18 117A-19 Figs. 67, 68c Photo 71a

This vessel has a slightly convex bottom and slightly concave sides; all of its surface is black with blotches of reddish-brown. The exterior walls and interior to 5 cm. have polished black slip, whereas the exterior base is unslipped

but slightly polished. The grooves around the pot are ca. 2.5 and 3.1 cm. from the rim with vertical to slightly diagonal fluting which runs from the second groove to the base. The cylinder is 14.7 cm. high with a rim diameter of 7.8 cm. (?).

Plan #22 117A-23 Figs. 67, 68f Photo 70

This flat-bottomed cylinder has slightly concave walls which suffered damage when the tomb collapsed. The entire vessel is black with the exterior walls and interior to ca. 5 cm. covered by a polished black slip. The exterior base, however, is unslipped but polished. There are grooves around the pot 2.5 and 3 cm. from the rim. Vertical fluting with shallow grooves ca. .8 cm. wide runs from the second vertical groove to the base. The vessel is 13.5 cm. high with a rim diameter of ca. 7.8 cm.

Plan #10 117A-25 Figs. 67, 68h Photo 70

Of buff paste, this fluted vessel has a slightly convex bottom and slightly concave walls. The exterior walls and interior to 6 cm. have polished black slip, with grooves around the pot ca. 2.5 and 3 cm. from the rim. Vertical fluting with shallow grooves .7 to .8 cm. wide runs from the second groove to the base. This is the only vessel on which the flutes do not end at the base with a tip visible.

Fluted Vessels

Fluted vessels occur at the nearby site of Uaxactun (R. E. with. 1955, Fig. 42, G1) and in Bu. 116 (Temple I) at Tikal.

MISCELLANEOUS SINGLE VESSELS

In the aisle there were several vessels which did not appear to belong to any grouping.

Polychrome Bowl with Quatrefoil Design Plan #9 117A-30 Fig. 47a, b Photos 47, 63

This vessel was near the bench in the west half of the aisle. Fallen on top of it, was one of the two of 13 stuccoed-incised cylinders that was not in the row. There was no positive or negative evidence in it as to whether it had ever contained food. It was covered with fill in which there was a great deal of red cinnabar mixed with reddish-brown rot (decayed wood?). As the bowl was lying next to the edge of the bench, it is presumed that the rot was pushed from the bench as the tomb collapsed. Within the vessel in the bottom layers of fallen plaster, there was brownish dust which could have been decayed food.

The vessel, of buff paste, has a flat bottom with slightly flaring sides. The entire vessel is slipped and polished; orange with red rim band .5 cm. on both the interior and exterior, then a .15 cm. thick black band on both sides. The

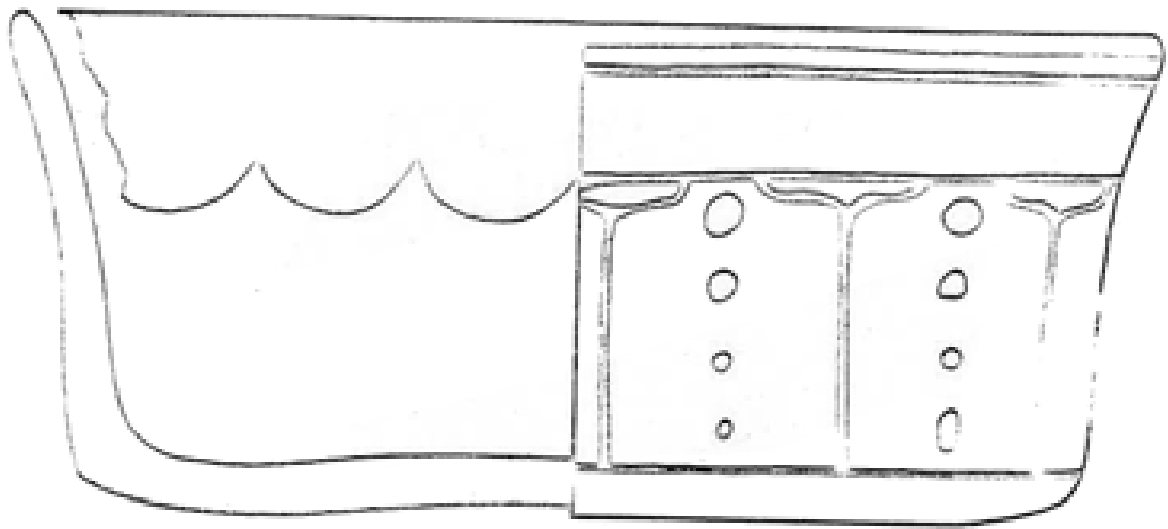

Fig. 69 117A-27

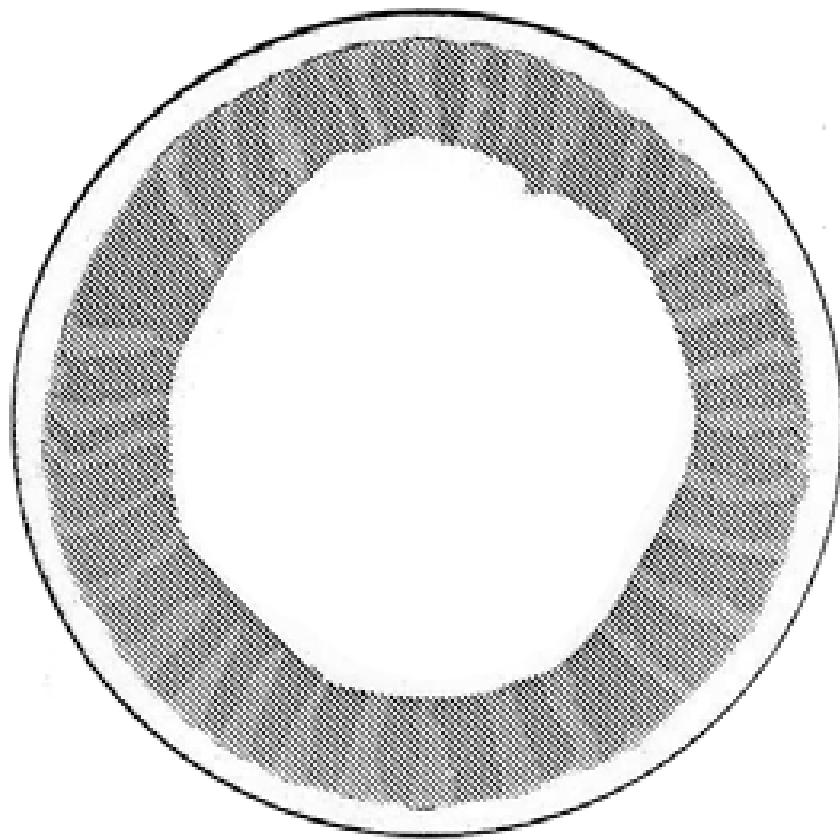
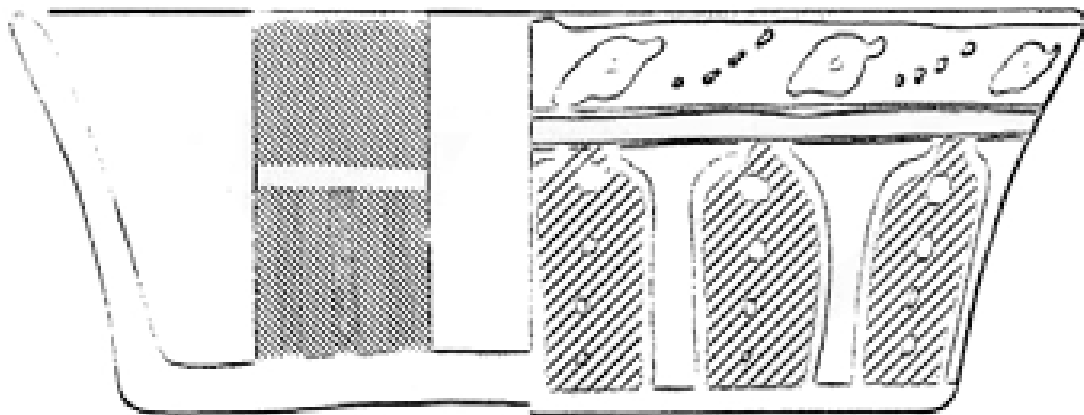

Fig. 70

117A-28 cat. base

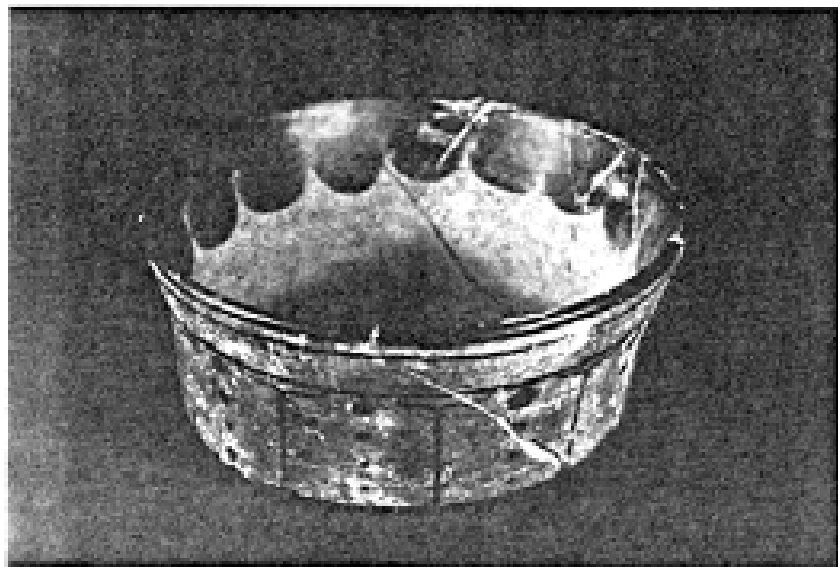

Photo 73 117A-27.

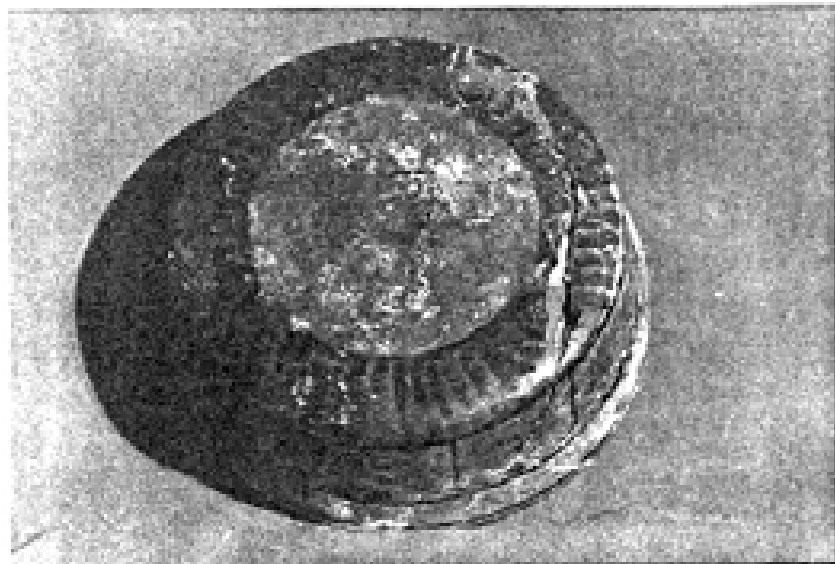

Photo 74 117A-27.

Photo 75 117A-28.

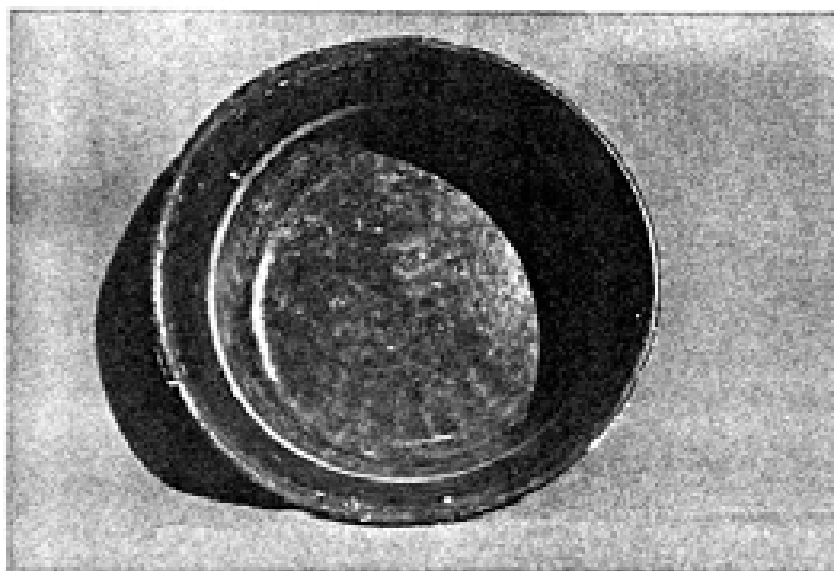

Photo 76 117A-28.



exterior and interior have four quatrefoil designs with red centers and black petals. The inside and outside quatrefoils are lined up with one another back to back. The interior base has a quatrefoil with a black center and red petals, the reverse coloration of the other designs. The red is 10R-4/10; orange 2.5YR-5/10. The bowl is 5 cm. high with a rim diameter of 14 cm.

Flat-bottomed Polychrome Bowl Plan #7 117A-27 Fig. 69a, b
Photos 73. 74

Found as it was in a tilted position next to the edge of the bench, it is possible but not probable that this offering was originally situated on the bench. Beneath it was a lot of red powder-rot; such rotted matter is not usually present in the aisle. It is equally possible that the bowl was in the aisle but was knocked into its present position as the tomb collapsed around it. Enough of the rot was present to measure 1 cm. in depth. This section of the aisle is alongside the place where the headdress fell when it rolled off the body, and the red rot may be the remains of this ornamentation. The entire vessel, of light orange paste, was slipped and polished. On the exterior are 10 panels of dress-shirt designs in brownish-black on cream. A brownish-black rim band has cream-colored scallops. A black, centrally-located glyph decorates the center of the cream-colored exterior base; a similar glyph occurs in a

similar position on a bowl from Bu. at Tikal. Around the edge of the base is a 2.8 cm. wide band of red-on-red stripes. The bowl is 8 cm. high with a rim diameter of 17.8 cm.

Flat-bottomed Flaring-sided Polychrome Bowl Plan #15 117A-28
Figs. 70 a, b Photos 75, 76

The situation in which this bowl was found makes it difficult to determine its original position. Somehow, it managed to end up on its side, squeezed between two of the stuccoed, incised cylinders next to the north wall. Presumably, it was originally on the floor but was pushed up as the tomb collapsed: or, more unlikely, it may have served as some kind of cover for one of the adjacent cylinders.

Slipped and polished over its entire surface, the exterior of this pot has a simplified dress-shirt design in dark brown and orange on cream. The exterior base has a narrow dark-brown band on the edge continuing from the sides, then a band ca. 1.5-2 cm. wide of red-on-red radiating stripes on an otherwise cream base. Around the interior is a narrow band of dark brown, below which is a 2.2 cm. red band followed by a .4 cm. wide cream-colored band. The rest of the walls and base have red-on-red stripes which are vertical on the walls and radiating outward on the base. The red is Munsell 10R-4/10; the orange 5YR-7/8. The bowl is

6 cm. high and 15.4 cm. in diameter at the base.

OFFERINGS CLEARLY FALLEN FROM THE BENCH

There were several non-pottery objects lying in the aisle that appear to have fallen from the bench. Their description is inserted here so that the three cylinders with painted throne scenes may be described together.

Four spherical jade beads and one spondylus shell were seemingly pushed over the edge of the bench when the tomb collapsed. These objects were found mixed in with fallen debris from 10 to 14 cm. off the floor of the aisle. Also in the aisle (Plan #68) were about 12 small pieces of nacreous shell, uneven in shape. These appeared to have fallen from the bench.

Stucco Fragments, Possibly Fallen from the Bench Plan #69
117A-97

The remains of a red and blue stucco painted wooden (?) vessel were found mixed with debris fallen from the wall and pushed off the bench. Whether its original position was the bench or aisle is not known. It is possible that it belonged in the aisle because the stucco fragments also occurred directly on the floor, as well as 5 cm. off the floor. There was a design in pale blue accentuated by black line, all painted over pink stucco. Unfortunately, the pieces were only minute fragments and were scattered in the collapsed

debris. Red fragments outnumbered those of blue. It is doubtful that this was a codex as only in one place did the stucco appear to be in (3) levels. The pink was 5R-6/4, tending to 6/6.

CONCLUSION OF DESCRIPTION OF POTTERY OFFERINGS OF THB AISLE

Polychrome Cylinder with Painted Human Figures Plan #40

117A-2, MT 177 Figs. 71, 72 Photos 48, 77

One of the three polychrome cylinders with painted human figures was at the east end of the aisle. Between it and the east wall there was an empty space of several centimeters. The vessel was found lying on its side with the "vulture-man" visible. The pot was so dirty that it was not recognized that a figure was painted on it, until long after it was uncovered. Although most of the vessels in the tomb were dirty, this one was unusually so; there may be some other explanation for this other than natural accumulation, unknown to the author.

The vessel, a polychrome cylinder of buff paste, has walls slightly concave; the bottom shows a slight depression due possibly to warping. The pot was complete and unbroken though cracked around the base. The interior has a red band on top of the rim and down to ca. 1.2 cm.; below this, a black band of .3 cm.; below this, speckled orange to ca. 2/3 down the walls. The red band is polished; the rest of the interior is merely just smoothed.

debris. Red fragments outnumbered those of blue. It is doubtful that this was a codex as only in one place did the stucco appear to be in (3) levels. The pink was 5R-6/4, tending to 6/6.

CONCLUSION OF DESCRIPTION OF POTTERY OFFERINGS OF THB AISLE

Polychrome Cylinder with Painted Human Figures Plan #40

117A-2, MT 177 Figs. 71, 72 Photos 48, 77

One of the three polychrome cylinders with painted human figures was at the east end of the aisle. Between it and the east wall there was an empty space of several centimeters. The vessel was found lying on its side with the "vulture-man" visible. The pot was so dirty that it was not recognized that a figure was painted on it, until long after it was uncovered. Although most of the vessels in the tomb were dirty, this one was unusually so; there may be some other explanation for this other than natural accumulation, unknown to the author.

The vessel, a polychrome cylinder of buff paste, has walls slightly concave; the bottom shows a slight depression due possibly to warping. The pot was complete and unbroken though cracked around the base. The interior has a red band on top of the rim and down to ca. 1.2 cm.; below this, a black band of .3 cm.; below this, speckled orange to ca. 2/3 down the walls. The red band is polished; the rest of the interior is merely just smoothed.

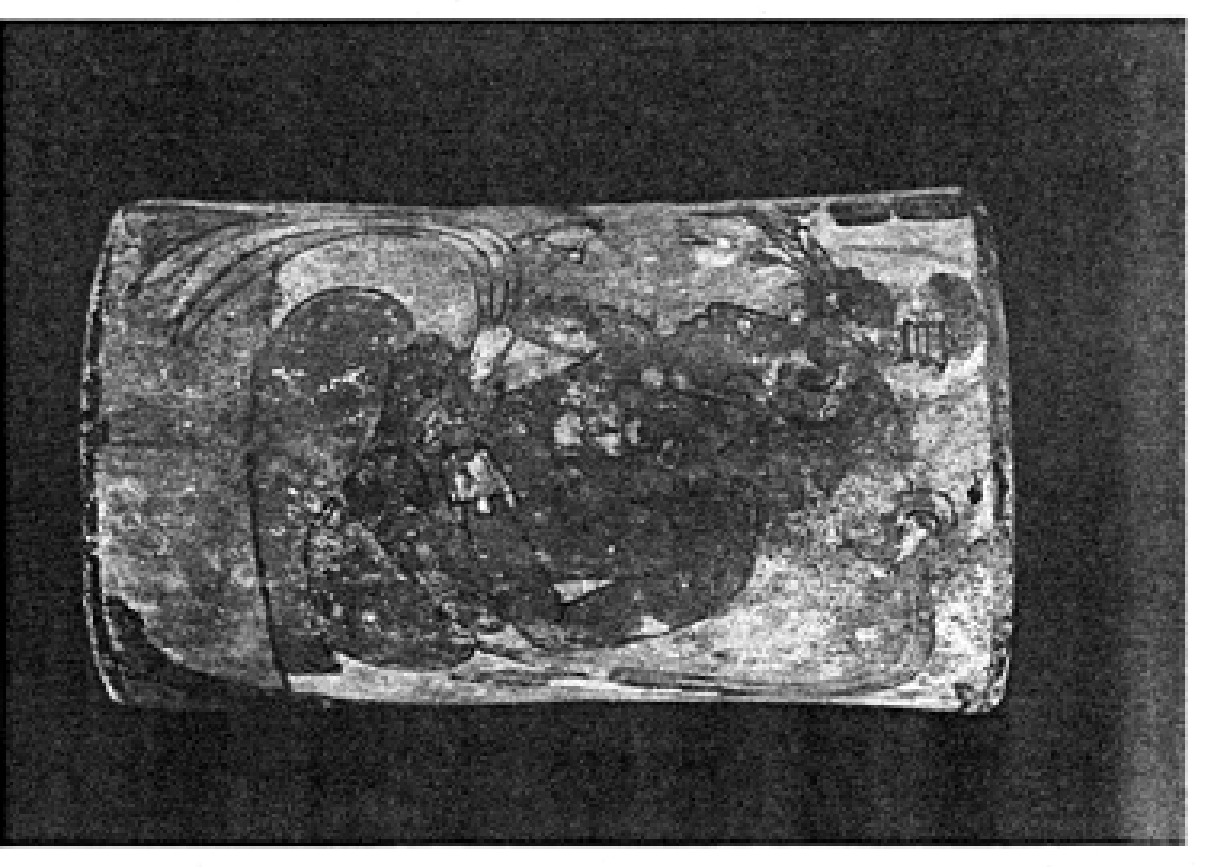

Photo 77 117A-2, 'dancing-man' cylinder.

Photo 77 117A-2, 'dancing-man' polychrome cylinder.





Fig. 31 Belt and design of 1934-5

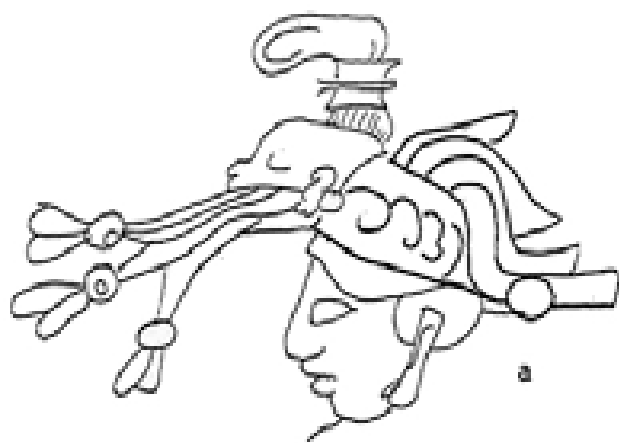

b



c



d



e



f



h



j



k



i

Fig. 72 Possible glyphic element in headdress.

The exterior base is unslipped and unpolished. The exterior walls have polished cream slip and a black band of .3 cm. just at rim and base. There are three figures around the pot, resting on the bottom line.

The pot's height is 17.4 cm.; rim diameter, 10.4 cm.; base diameter, 10.1; walls, .4 to .7. The Munsell colors are:
 Brown of bodies varies 5YR-5/8, 6/8
 Brown of loincloth and headdress closer to 5YR-4/6
 Red ca. 10R-4/1-
 Orange ca. 5YR-7/10, 6/10, 6/12
 Background ca. 2.5Y-8/4

There is specular hematite on the end of the "cigar", on the bird's crewcut, and on the lotus in the headdress of the seated figure.

The Human Figures

The main figure is seated on a plain, rectangular, orange painted platform or throne. The man is seated facing front, but his head is turned to the observer's left, addressing a seated figure. The man wears only a plain, red loincloth with a round knot in front. For jewelry, he wears jade bracelets, earplugs, and a single strand of spherical beads. The jade bracelets are of interest, because they are possibly identical with those worn by the occupant of Bu. 196, see p. 190. They are tubular jades with pendants of fitted shell. There are nine spherical beads of the necklace showing--exactly the number of beads visible on the dancing figure. It may be coincidental, but nine is a sacred Mayan

number. The typical Classic Mayan necklace goes down the back; so, there are numerous beads not depleted in a front view. The earplugs are more like those on the headdress of the deceased (p. 183) than those actually on the ears (p. 184). It is difficult to determine exactly what the personage holds in his hands, but it appears to be a bundle of feathers. One source of the problem of identification is that the Maya potters seem usually not to have had green paint readily available, because all the details that appear to be jade are painted a dusty brown-grey.

The back element of the headdress is a water lily (Fig. 75), easily identifiable by its similarity to many less conventionalized representations found elsewhere. The face on the front of the headdress may be glyphic but is not readily identifiable. Its closed eyes may be indicative of death, as one of the glyphs in the codices which signifies death has closed eyes. Otherwise the head is somewhat similar to that on the back of the left figure on the bird-man vessel. The featherlike objects are not issuing from the beast's mouth but from his earplug.

The type of throne is similar to many found in Late Classic palaces at Tikal, such as Str.6D-38-1st-A; it is similar to that of the "fat man pot" (Fig. 78) but different from that of the "bird-man pot" (Fig. 78).

The second figure, the "vulture-man", is in complete profile, sitting cross-legged facing the throne figure. Both

men are conversing in sign language. The "vulture-man" is wearing a fancier loincloth than the other figures depicted. His predominate feature is his vulture and snake headdress. The bird is identifiable as a vulture because of the knob on the beak. Such a headdress is reminiscent of those in the Bonampak murals.

The third figure is in twisted perspective, with its legs, arms, and head in profile, but the upper body in front view. He is advancing to the observer's left, yet is looking to the right towards the throne figure. He is unusual by virtue of his prancing movement and the object in his mouth. It is possible that he is dancing. The object protruding from his mouth has a bright red tip accentuated by specular hemitite. At first glance, it looks like a cigar but may be a musical instrument.

The writer is not an authority on glyphs and is unable to readily identify the glyphs. Identification is made additionally difficult because the glyphs are very simplified.

Something noticed by everyone who has looked at this and the other throne scene on 117A-3 is the difference in the facial features; pug nose, deeper mouth, and more protruding lips between the main figure on the throne and the subordinate figures in front.

Polychrome Cylinder with Throne Scenes Plan #20 117A-1 Figs. 73, 74 Photo 78

Next to the jade mosaic container, the most magnificent work of art within the tomb was a small pottery vessel found badly smashed in the middle of the aisle in the vicinity of the fluted vessels. Although not situated near the previously-mentioned polychrome vessel, both show throne scenes and both will be discussed together. The third vessel depicting a throne scene was found on the bench and will be described on page 167.

The well-formed walls, of buff paste, taper slightly towards the rim. Of all the vessels this has the thinnest walls--from .3 to .4 cm. thick,--and is the best nada. The bottom is marked by a slight depression. The orange-slipped interior was decorated near the rim with a series of circles in brownish-black and then lightly polished.

The highly-polished exterior walls as well as the base have a cream slip with black speckles. A rim band painted blue (now mostly flaked off) was delineated by a narrow strip of brown; the throne scenes were circumscribed by this line and another similar one near the base.

The basic colors of the figures were red with most of the rest being background. The deepest red was 10R-4/10 with wash areas a pale version of this. Blue paint occurs on the rim and on two glyphs in upper band and one in each subsidiary



Fig. 22. (1981) (Copyright from artist 1981)

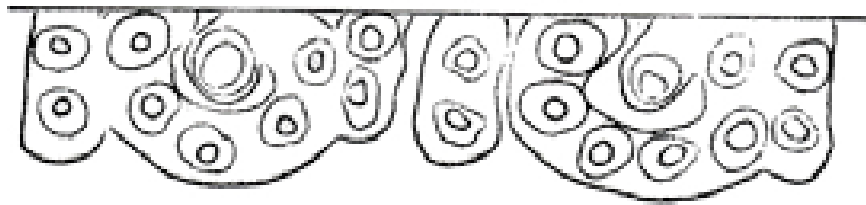

interior design

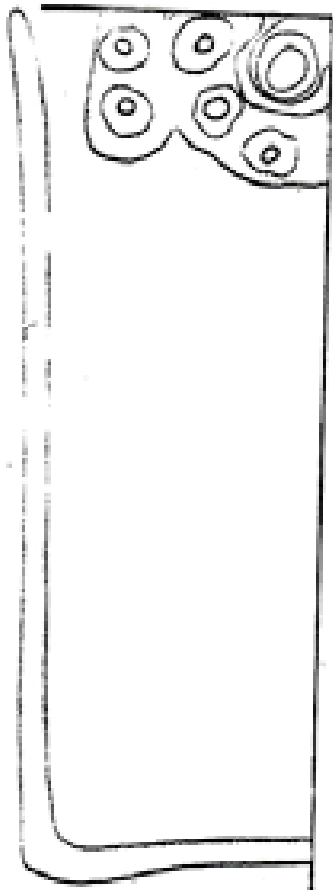

Fig. 74 117A-1 NPA-V



Photo 98 117A-1, 'Blrd-man' polychrome cylinder.



photo 28 117A-1, 'blind-man' polychrome cylinder.



text; on the headdress of both bird-men; on bracelets, necklace, earplugs, and headdress of the figure seated on the jaguar skin throne; and on the headdress of the other enthroned figure. The blue was too fragmentary to type accurately: the best approximation is 10BG-7/4. The vessel's interior is close to 2/5YP-5/10, 6/10.

THE GLYPHS

The style of the glyphs is the same as found on the monuments and some of the better painted pots at Tikal and is different from that of those on the "dancing man" pot, which is closer to the codex style.

The Upper Band of Glyphs

Within the upper bend, some of the glyphs are painted red with two of the glyphs colored blue (at least one of the personified uinals and possibly the other, it being difficult to tell from the photographs). Numbering the glyphs on the drawing, from left to right, the red painted glyphs are: 3, 4, 7, 10, 13, 14.

The author is not a glyph specialist and the glyphs have not yet been studied by Dr. Satterthwaite and Chris Jones, the Tikal experts on this subject. A few of them the writer has been able to identify using Thompson's two catalogs, but there are several glyphs the author has not been able to identify. As to their meaning and relation to texts

on other pots, the author is unknowing.

The Figure Glyphs

Next to each figure is a group of glyphs which obviously refers to that person and may conceivably give his name and/or title. The glyphs in front of the headdress of the figure seated on the jaguar skin-covered throne are red painted; all others are in brown-black outline on the background of black-speckled cream. It is difficult to determine on the basis of this vessel alone exactly which glyph panel relates to which figure; but, the arrangement of the glyphs on the dancing-man pot hints that the ahau panel refers to the bird-men and that the upper panel refers to the throne figures.

The ahau panels each contain three glyphs: an inverted ahau, glyph 592, and a head-form meaning "green, new, or strong". The two ahau panels are almost identical, the major difference, possibly meaningless, being that glyph 592 is shown in two different positions; also, on the right panel the ahau is in the simplified form, whereas on the left panel the ahau has a nose. The different representations are probably artistic and not linguistic. The glyphs relating to the throne figures are not similar.

THE BIRD MEN: The Bare-backed Bird-man

A complete stylistic and comparative analysis of the

throne scenes is outside the scope of this report, but a few comments will be made. Of primary importance is the fact that the figures appear to be human, with bird attributes only as part of a costume. This may be seen where the skin of the left bird-man is represented by reddish brown paint: i.e., the hands, the feet, parts of the back and side of the waist and possibly the back of the neck. Costumes which almost completely cover the human figure are found on several well known pottery scenes: i.e., on the Chama vase (Morley, 1956, Pl. 92a) and on one of the vases from Uaxactun (Ibid., 91), in both of which the costume merely forms a black covering.

The most characteristic feature of the bird-men are their beaks. The author first thought it was a hummingbird beak, others suggested mosquito. A careful analysis of this mask will show that it possesses certain features that may eventually provide a proper identification of it. Its most pronounced feature is the length of the beak and its thinness. The length and proportions are reminiscent of a hummingbird, but hummingbirds do not have hooks at the end of their beaks. The presence of a hook at the end of a long, slender, beak suggests that the bird is some sort of freshwater species. A final feature that may help in eventual identification is the slight knob where the nostril is located next to the face.

An additional feature of this bird is the glyph which

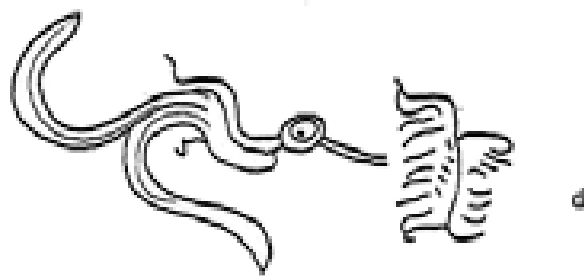
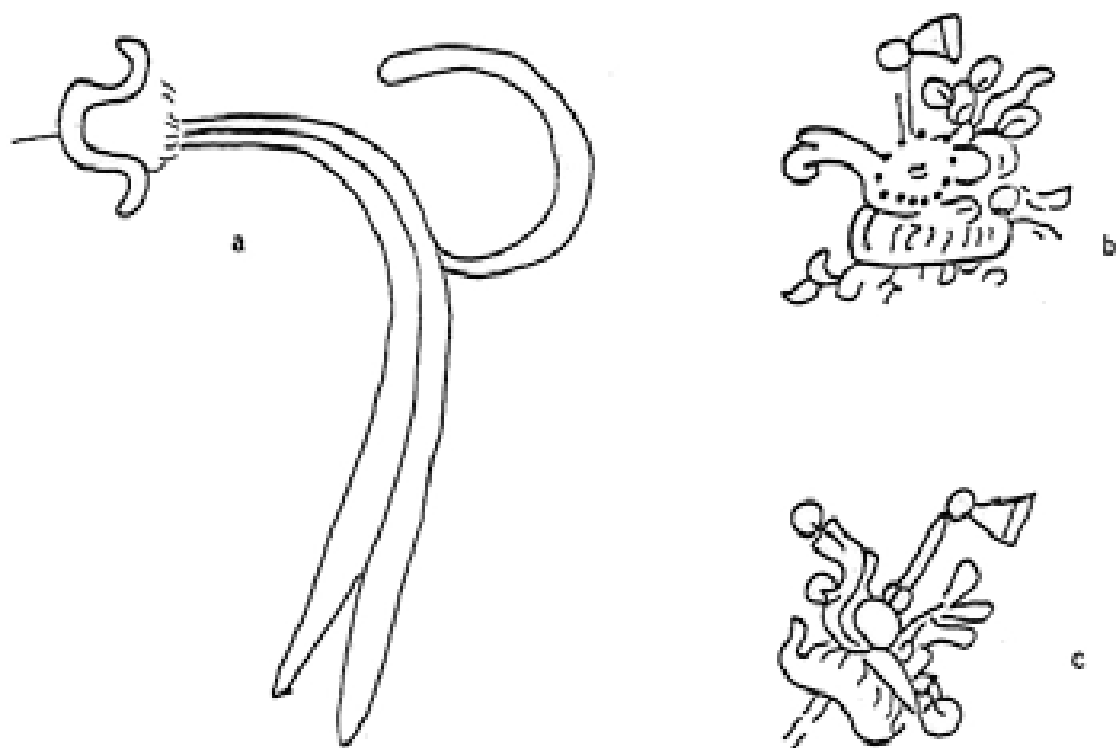

Fig. 75 Water lily designs: a, 117A-2; b-d,, 117A-1; e, Bu.160; f, Bu.??

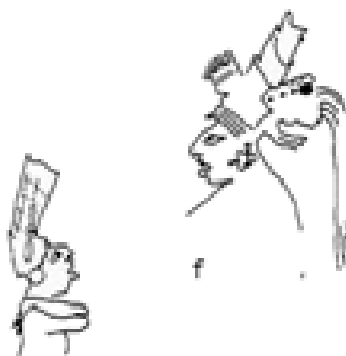
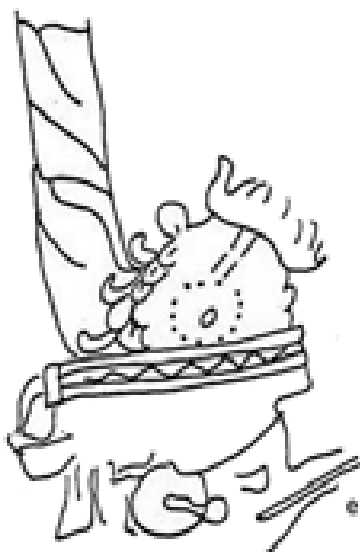
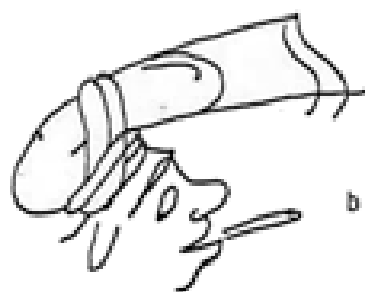
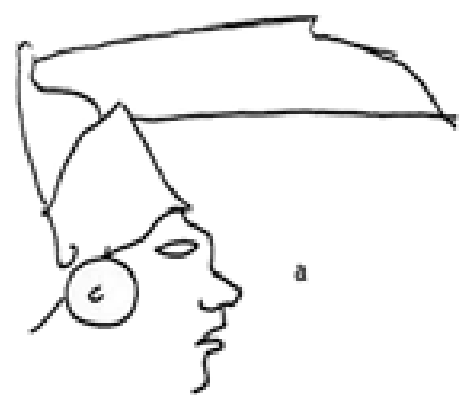

Fig. 76 Headdress 'stacks', all from Bu.196 except 'f' (from Bu.116).

is speared by the beak. This is a unique position for this glyph, but encircling dots occur on bird beaks in the Mayan Tro-Cortesianus Codex (Madrid). Frigate birds, ocellated turkeys, and pelicans are shown there with the dot motif. The only place in Classic art where a similar motif may be expressed is on a relief panel in the Dumbarton Oaks Collection (Coe and Benson, 1966, Fig. 1). The panel is too weathered and the photograph too small to tell for sure, but the bird may be the same. Here the bird is a headdress element and not a face mask as on the Bu. 196 pot.

The various elements which go together to make up the headdress are difficult to separate and identify. The mass of spherical objects appears also in the basket of offerings in the right hand throne scene. Fortunately, both headdresses are almost identical--differing only in the arrangement of the conical headdress cloth. The uppermost element of the headdress is the long-nosed god protruding from a water lily. (A long-nosed god also appears on the headdress of the right hand throne figure and a water lily appears in the headdress of the left throne figure), (Fig. 75).

The projecting headdress piece is found on the other two figure-painted pots from Bu. 196, on many other Late Classic pottery figures, i.e., from Temple I, Bu. 116 (Coe, 1966, p. 42), and on the Bonampak murals. This ornamental apparel appears to be cloth, perhaps wrapped around some strengthening member.

Besides the simple, fringed cloth mask and costume, the bird-man wears jade earplugs similar to those worn by the other figures on the vessel and somewhat similar to those worn by the deceased occupant of the tomb--jade wristlets with fitted shell pendants and some sort of obscure chest ornament complete his costume.

Of significance is the gesture the figure is making with his arms and hands and the careful positioning of his fingers. This sign language is distinctly obvious on all three of the figure-painted pots.

THE BIRD-MEN: The Bird-man with Offerings

The bird-man on the right is similar to the one on the left except for the positions of the hands, the position of the extended headdress element, jade jewelry, and the presence of offerings in front of him. The hand and arm positions have been dealt with in the preceding section; the jade wristlet is simpler, but the chest pendant is considerably more a complicated and, unfortunately, undecipherable. Also, on the back of this figure is what may be the back part of the jade necklace and, in red, some rope-like form hanging from the figure's left hand.

The Offerings

In front of the right bird-man are two containers of offerings. The container immediately in front of the figure's

feet is a pottery vessel with a sky glyph as a decoration (Fig. 76). Glyphs similar to this are illustrated in Thompson (1960, Fig. 31, 52 ff.). Interestingly, this same glyph occurs on the headdress of a long-nosed god (Ibid., Fig. 31, 58) and on an offering of water held by a jaguar (Fig. 76). The catalog number of the glyph the author is unable to determine as many main signs have a sky-band as an infix.

(M. Coe, 1966, Fig. 49b) shows a similar glyph as being the Emblem Glyph of the neighboring site of Naranjo. The Tikal Emblem Glyph (Glyph #6) is on the glyph band.

The second container is of basketry with spots perhaps to represent jaguar skin. Within the container is some plant or fruit which the author is unable to readily identify.

THE THRONE FIGURES: The Figure on the Jaguar Skin Covered

The principal figure on the left throne scene is in full profile seated with his back against the throne's backrest. As the predominate feature of this figure is the throne on which he sits, this object will be discussed first.

Small round thrones with backrests are not at all common; nor are round thrones. Of thrones with oval stela-shaped backrests, almost all the classic examples are of a large rectangular type (Fig. 77) found at Tikal, Piedras Negras and Nebaj. Round thrones with backrests are, however,



a



b

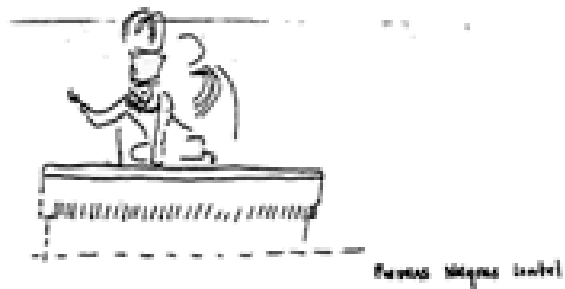

c

Fig. 77 Rectangular thrones with stela-shaped backrests.

found in the codices.

Round thrones without backrests look very much like altars, and the only example that is well known is that illustrated on a cylinder vase from Burial A-31, Uaxactun (Kubler, 1962, Pl. 91a). Here two dignitaries are shown seated on very small altar shaped thrones or cushions. They are smaller than those depicted on the bird-man vase and there is no backrest. Their complete covering with jaguar hides is slightly different from the half-covered thrones of Fig. 73. As an aside, it is noticeable that the toes are depicted in a similar manner on both vessels.

Thrones covered by jaguar skins are the rule, not the exception, and are so frequent as to make references unnecessary. Although the right throne is not completely covered by a jaguar skin, part of the backrest is.

The jade jewelry, here painted light blue, and the clothes worn are similar to those worn by all the figures on this vase and other Mayan figures. The most characteristic element of the clothing is the edge of fringes, possibly conical.

Of perhaps more interest is the headdress worn by this, the left hand, figure. The most easily discernable element of this ornament is that of the water lily on the front, out of which feeds a heron or some long-billed water bird. A second feature of the headdress is the conical wrapping of cloth which has already been mentioned with respect to the

way as on the headdress of the throne figure on the dancing-man cylinder. From the forehead of the animal head issues a plant-like stalk with a decorative object at its end. The differences between this animal face and that of the 117A-2 vessel is that in the latter the mouth of the animal is hidden by the "feathers", whereas in the former the feathers could be described as being on the other side of the face and merely visible through the open mouth. There are not many features preserved on the face, but those which are and the plant form issuing from the forehead (see jade jaguar on p. 176) indicate that this may represent a jaguar.

What appears to be hair rendered in thick black, best visible in the color photograph, is noticeable above the neck springing from between the white cloth part of the headdress and the round tufted element. In the other figures all the hair is hidden by the headdress. It may be purely coincidental, but the figure under discussion is the only one without the projecting wrapped headdress element; in the other figures perhaps this cloth is a wrapping around the hair. The round tufted ornament is similar to that of the other throne figure on the same vessel but is not common elsewhere.

The Throne

The throne, as well as the whole scene, is on a slightly larger scale than the other throne; likewise there is a difference in decoration. The backrest has only the front third

of the side covered with jaguar hide; the remainder of the throne back is covered with the main element of Thompson's glyph #614 to which he gives the representation of thatch (Thompson, 1962, p. 236). This is a common decoration for the sides of thrones appearing on two Late Classic carved lintels at Tikal from Temple I and III (Fig. 76). On the side of the bird-man vessel throne, there is possibly a glyphic element which appears on a throne depicted on a Temple I lintel (Fig. 76). In the former representation the right side is reconstructed, because the element is hidden by offerings and the only one nearly complete is on the edge with one side on the part of the throne not visible. The broken line reconstruction is taken from part of another similar element that peeks through the offerings. Perhaps it should be reconstructed like the one from Temple I.

OFFERINGS ON THE BENCH

THE POTTERY OFFERINGS

Polychrome Cylinder with Throne Scene Plan #2 117A-3 Fig. 78
Photos 79-82, 84, 86

The second pottery offering uncovered by the author was a beautifully painted cylinder vessel standing next to the south wall of the tomb (Fig. 78), cracked but not broken, with the fat man on the north side. The walls of buff paste are slightly concave, as is the bottom. On the interior there is a polished red rim band to 1.1 cm.; another 3-4 cm.

of polish below this may have cream slip or may be just the natural color of the clay. The exterior base is unslipped and polished. On the exterior there are red bands at the rim (.8) and base (1.2 cm.) wide. Two narrow black bands (ca. .2) occur below the rim band and above the base band. The orange used as a background for the throne scene was painted in wide vertical strokes. The scene itself is merely outlined in black on this background with some color added for details.

The vessel is a maximum of 22 cm. high with walls .6 cm. thick and a rim diameter of 13.7 cm. The Munsell colors are: red, 10R-4/10; orange at its deepest is ca. 2.5YR-6/12, 6/14.

There is a textile impression on the base and on the side near the base; a loose gauze weave like 12U-37/27 and 12U-38 (Bu. 195) (V. Greene, on cat. card), which was noted in the field by the author as a thin black film completely surrounding the vessel. This black layer was held next to the vessel by the fallen plaster. This is the only vessel so noticeably wrapped. It is possible that others were too, but this the excavator doubts. The inside of the cylinder was filled with a flaky, light yellow crust up to within 5 cm. of the top. Below this was a solid encrusted material honeycombed with the casts of bean and/or corn kernels. There was nothing under the vessel except for a few grains of dust. There were traces of cinnabar all around it except on the west side.



Photo 79 117A-3.

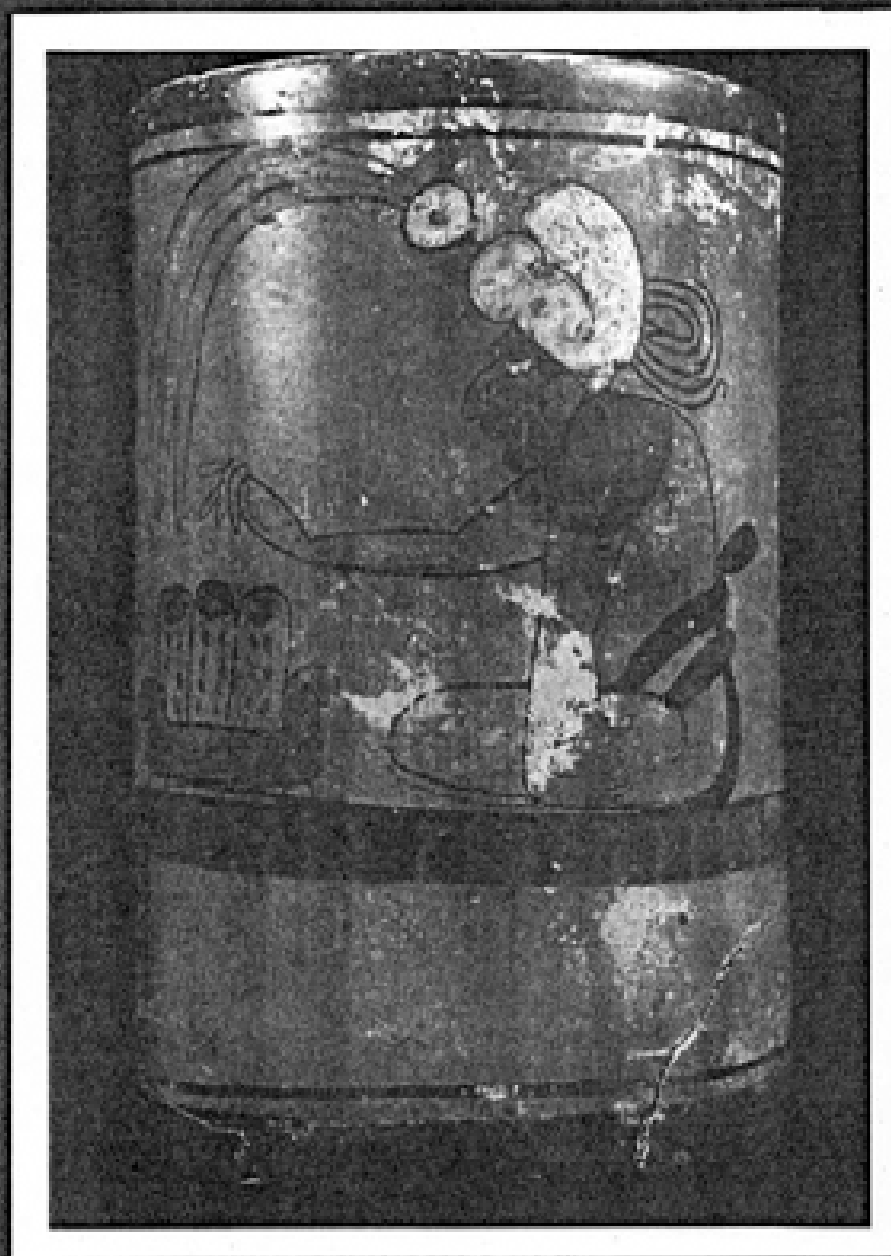

Photo 80 117A-3.

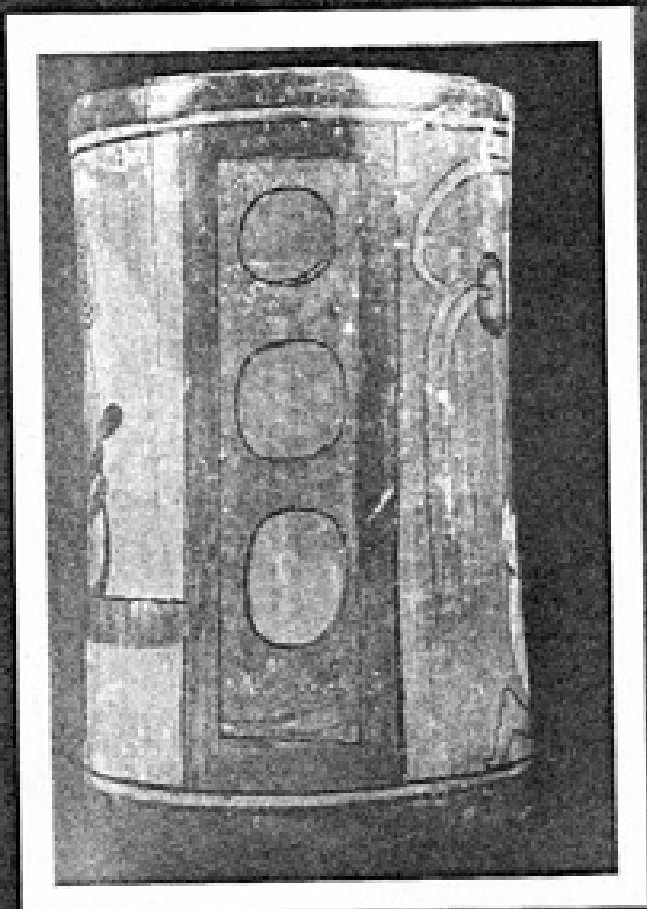
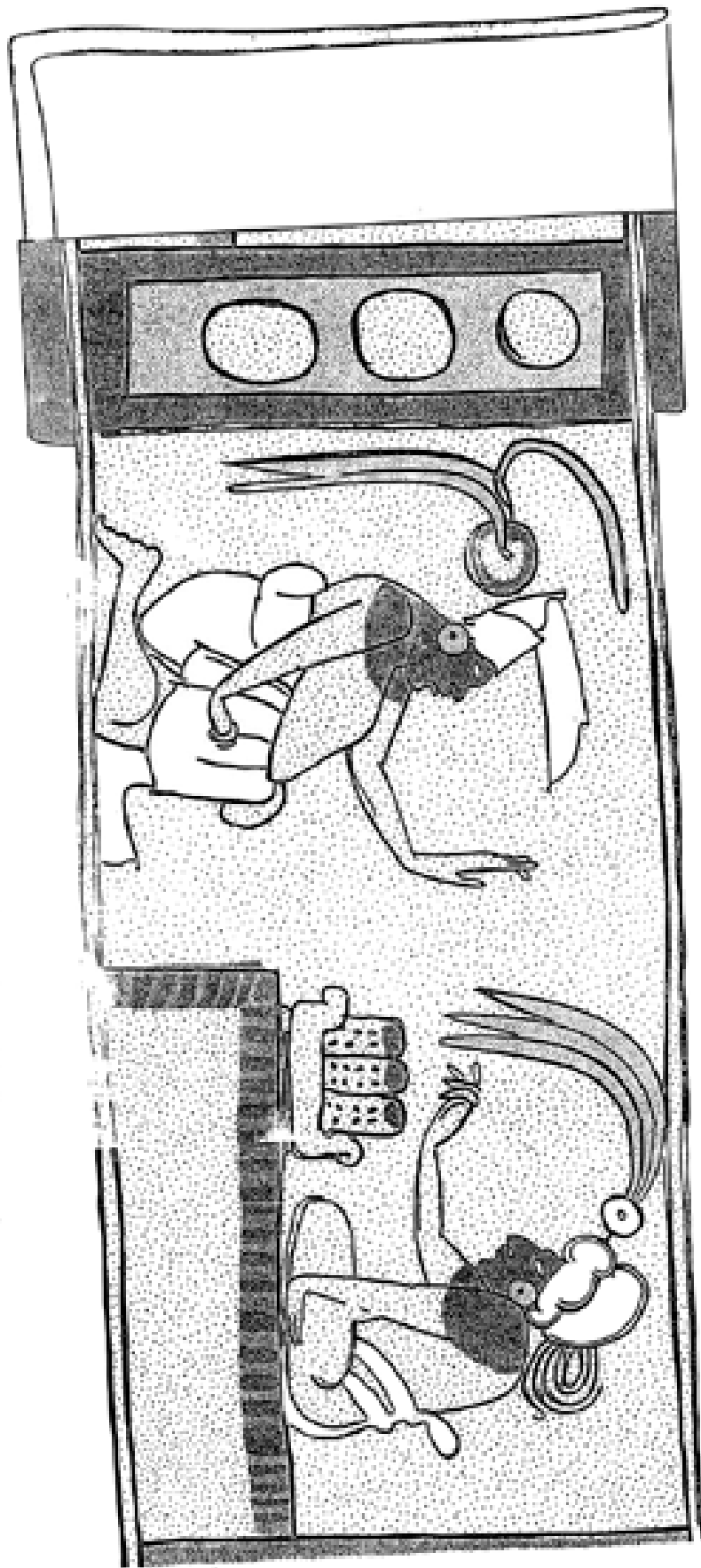

Photo 81 117A-3



Photo 82 117A-3

Fig. 78 Doll and design of 1174-2 (actual size)



The Fat Man

Kneeling in front of the throne and shown in profile is a person exceptional in his obesity. He wears a simple, undecorated white loincloth, a simple earplug without pendants and an uncluttered headdress. The earplug and the feathers issuing from the back of the headdress are painted grey as are those on the dancing-man vessel. Evidently, the Mayan painter did not have green paint readily available, because these are clearly meant to be green jade and green feathers. The single upturned feather is similar to the method of depiction employed on the other figure-painted pots from this burial, as is the main element of the headdress. The figure has white pupil-less eyes. His potentially meaningful gesture and distinctive facial characteristics are of interest.

Something present on this vessel and not on the others from this burial is the treatment of the head and shoulders, painted as they are in red with the rest of the body left the color of the orange background. On one of the Bu. 116 vessels this appears to be some sort of mantle of light cloth (Coe, 1965, p. 42); or, it may be body paint.

The Figure on the Throne

In profile, seated on the rear half of the throne, is a man with an outstretched hand "receiving" an offering, probably of corn, in front of him. He wears a very plain, black loincloth and a plain bonnet-like headdress with three

feathers in front. Elsewhere, he wears only earplugs of jade, painted grey. His head and shoulders are painted red in the same manner as the fat man. His eyes are white and lack pupils.

The Throne and Offering

The principal figure, described above, is seated behind a pottery (?) container with three round, conical (?) offerings. The red dots and the rounded shape suggest maize. The red semicircle at the top of each of the ears of corn is similar to the red semi-circle on the two human figures' shoulders.

The throne is of the plain rectangular variety found so frequently in Late Classic palaces at Tikal, Str.5D-38-1st-A, for example. On the edge of the throne is a strip of red-on-red stripes.

The Panel

A rather unusual decoration takes up some room on the vessel not filled by the human figures. It is unfortunate that it is not shown on the official drawing behind the throne on the right of the drawing, instead of behind the fat man on the left of the drawing, because it may have been meant to sit behind the throne as some sort of backdrop. Within the grey panel inside a red-black outlined rectangle, are three circles with black outlines. They may just be

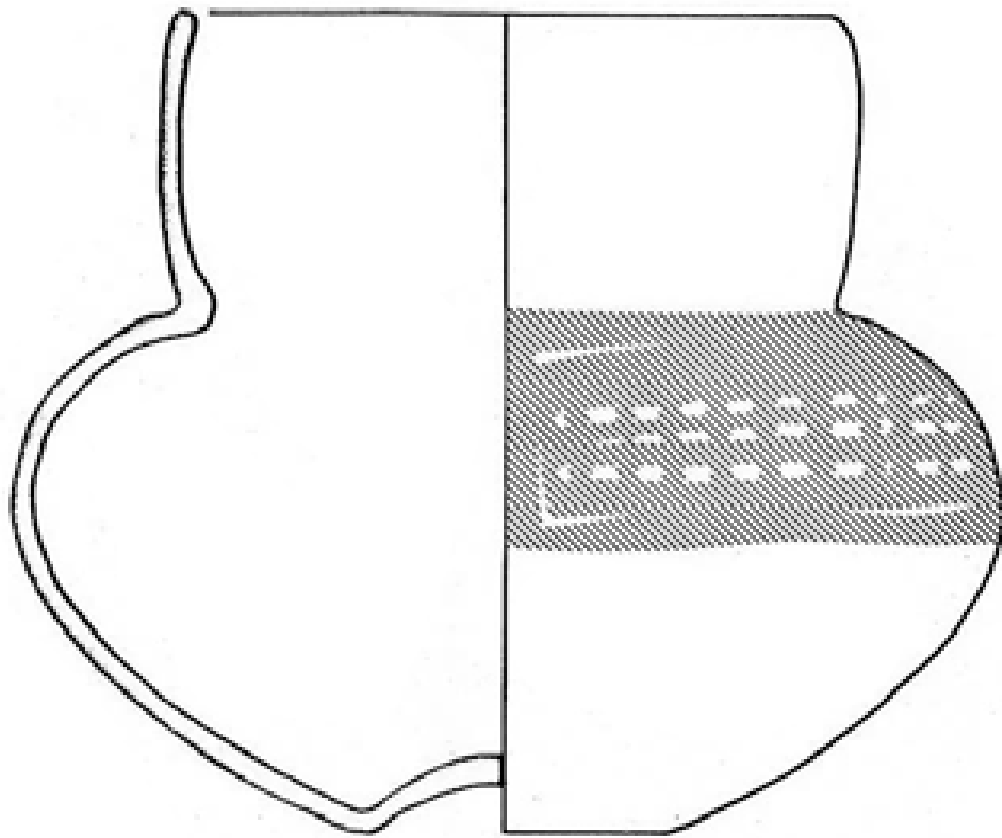

117A-4B

meaningless decorations, or they may represent kernels of corn (Photo 81).

Large Cooking Pot Plan #1 117A-48 Fig. 79

The first pottery offering to see the light of day after a 1200 year hibernation was a large buff-ware cooking pot. This vessel was one of three pots found on the bench and was found near the south wall of the tomb in the east sector. The inside of this container was coated with black soot, and in its bottom was a 2 cm. deep layer of compact, black carbonized material. The vessel looked as though it had been used for a long time.

The vessel's neck is wide and almost straight. The base is dimpled. The slipped and polished upper body has sections of check design in red on the buff paste. The pot is 24.6 cm. high; its greatest diameter is ca. 29.5 cm., and its rim diameter is ca. 20 cm. The red of the pattern is 7.5R-3/6 on the Munsell scale.

Large Tripod Plate with Dress-shirt Design Plan #3 117A-37
Figs. 37a, 38 Photos 42, See also p.129

This large, side-flaring tripod plate was centrally located, west of the head of the deceased. In Bu. 116, Temple I, there was a similar type of vessel located in a similar position (Photo 43 and p.). Besides the biconically drilled "kill hole" in almost the exact center of the

vessel, the plate was missing one of its tripod feet. That the plate was placed in the tomb without one foot rather than one foot's having been lost in excavation is proved by the impressions made by the plate in the soft plaster of the bench top. Here were the perfect impressions of two feet and the jagged scar left where the footless part of the vessel had been forced into the plaster by the weight of the collapsed walls. There did not appear to have been any food in this plate, because when pieces of plaster were pried from its interior bottom, there were no decayed food particles visible or any impressions of food or seeds.

The rest of the details of this plate are summarized in the chart on tripod plates on page .

WOODEN OFFERINGS

It has always been presumed that Mayan tombs contained many offerings of wood that have decayed long before the excavator reaches them. The discovery of a treasure of wooden objects by George Guillemin in Bu. 195 in Str.5D-32 on the North Acropolis made the author keep a special eye out for the remains of wood, usually first noticed by rot or flakes of painted stucco. Unfortunately, the factors of preservation within Bu. 196 were not favorable for the sort of preservation found in Bu. 195; and, in addition, the author was unskilled in the removal of crumbled wooden artifacts.

Large wooden Bowl with Stuccoed Rim Plan #65 117A-100

The first hint that wooden objects were present among the offerings came when the large stones were removed from over the offerings. One large stretcher south wall had fallen plaster side down; when it was picked up, on its plastered surface was noticed a shallow impression, ca. 1 cm. wide, defining about a quarter of a container with a diameter of approximately 34 cms. Light blue stucco adhered to the impression. The position of this vessel was placed on the plan just as it was for pottery vessels. After the stone was removed (taken to the lab), a circle of rotted wood could be seen pressed in on both sides by loose plaster and debris from the fallen walls. With infinite patience and special preservatives it might have been possible to salvage some part, or at least the general shape, of this vessel, but those consulted thought that the results would not warrant the effort.

About 2 to 3 cm. from the floor, a soft, dirty white layer 1.5 cm. thick was found. The exact nature of this substance has not yet been determined. It was somewhat similar to the white "marl-like" material covering the carved, incised bones but not as thick, not as pure white, and softer to the touch. Directly under the layer of white, was a thin layer of cinnabar. The cinnabar lay over what was presumed to be the bottom of the bowl.

That the wooden bowl was strong enough to make a dent

in a heavy stone indicates that the walls of the tomb collapsed before enough time had elapsed for the wood to rot even partially.

Wooden Bowl Filled with Hematite Plan #43 117A-99

To one side of the group of bones lay the disintegrated remains of a low wooden bowl which seemed to contain a granular red substance, probably specular hematite. One centimeter off the floor, the entire .4 cm. thick circumference of the approximately 21 cm. diameter was visible. 3 cm. off the floor were the remains of what may have been a wooden lid for the bowl. This lid was flat and consisted of wooden "boards" approximately 5 cm. wide. No stucco fragments were found anywhere in the vicinity.

The notes are not clear as to the exact position of the hematite within the bowl. Evidently there was hematite both under and over the "lid" to a depth of 3 cm.; some areas of the bowl did not contain any hematite at all, perhaps it all shifted to one side when the tomb collapsed. See also description of Plan #69 on p. 152, a possibly wooden object in the aisle.

VESSELS OF STONE

White Stone Vessel Plan #50 117A-49 Fig. 79 Photos 83,

In the vicinity of the jade jaguar and jade mosaic con-

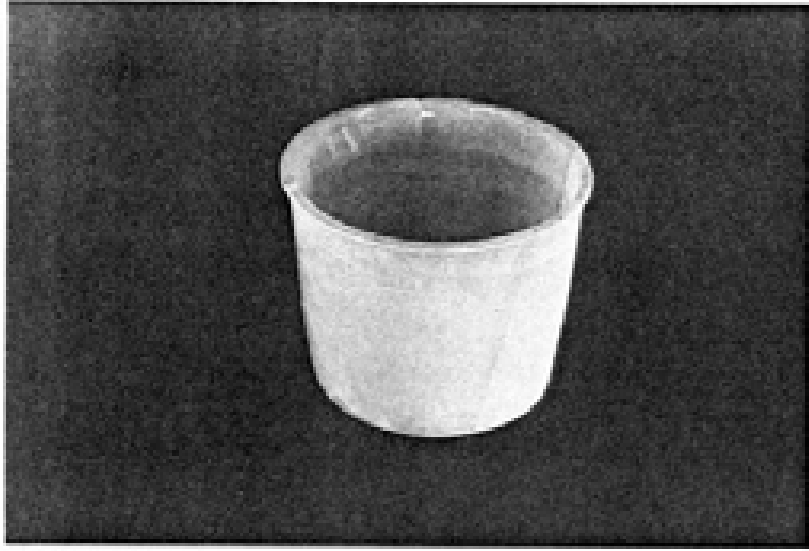

Photo 83A 117A-49, onyx marble container

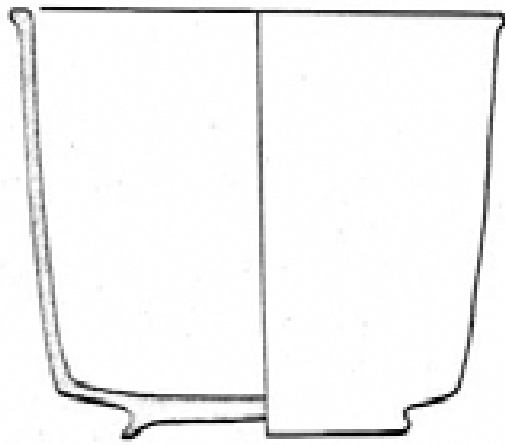

Fig. 80 117A-49

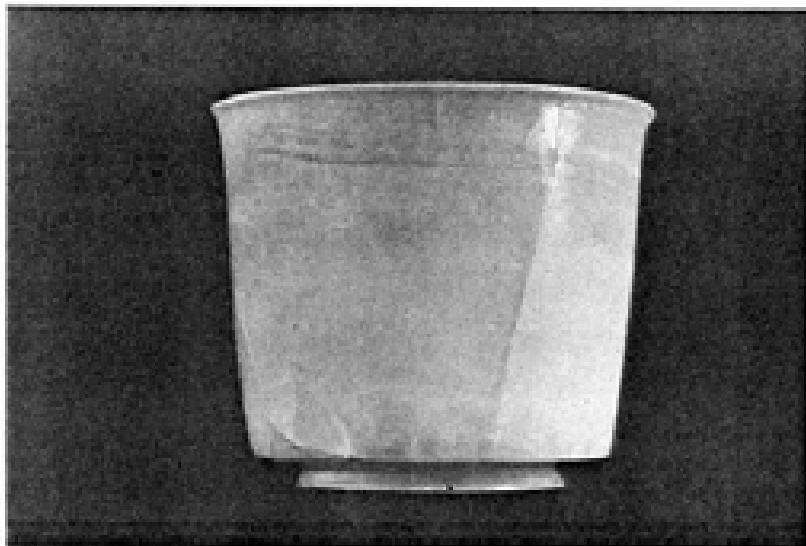

Photo 83B 117A-49.

tainer several cm. from the south wall was the broken remains of a beautiful vessel of white stone, apparently alabaster or onyx marble. Unlike the onyx marble vessel from Bu. 116, this one was not stuccoed or painted.

On the stone there was slight horizontal banding. Although not noted on the catalog card, the author remembers that the vessel was highly polished and smoothed on the outside and on the inside lip down about 2 cm. The rest of the interior walls were rough. On the interior base there was a bit of brown powder, but not enough to pass positively as food remains. Below the vessel was a layer of red-brown powder.

The rim diameter of 14.6 cm. was slightly larger than the base diameter of 11.7 cm.; the vessel was 12.4 cm. high with a sharp angle at the base with the ring stand. The rim was flattened and slightly everted.

JADE OFFERINGS

JADE OFFERINGS NOT WORN BY THE DECEASED

Two objects of jade were off to one side of the body and were not on the body of the deceased.

The Jade Jaguar Plan #47 117A-50 Fig. 81 Photos 8b, 85, 86

Laying on the south side of the dais, facing east, was found an unusually large piece of carved jade. Its maximum



Photo 84 Offerings on the bench.

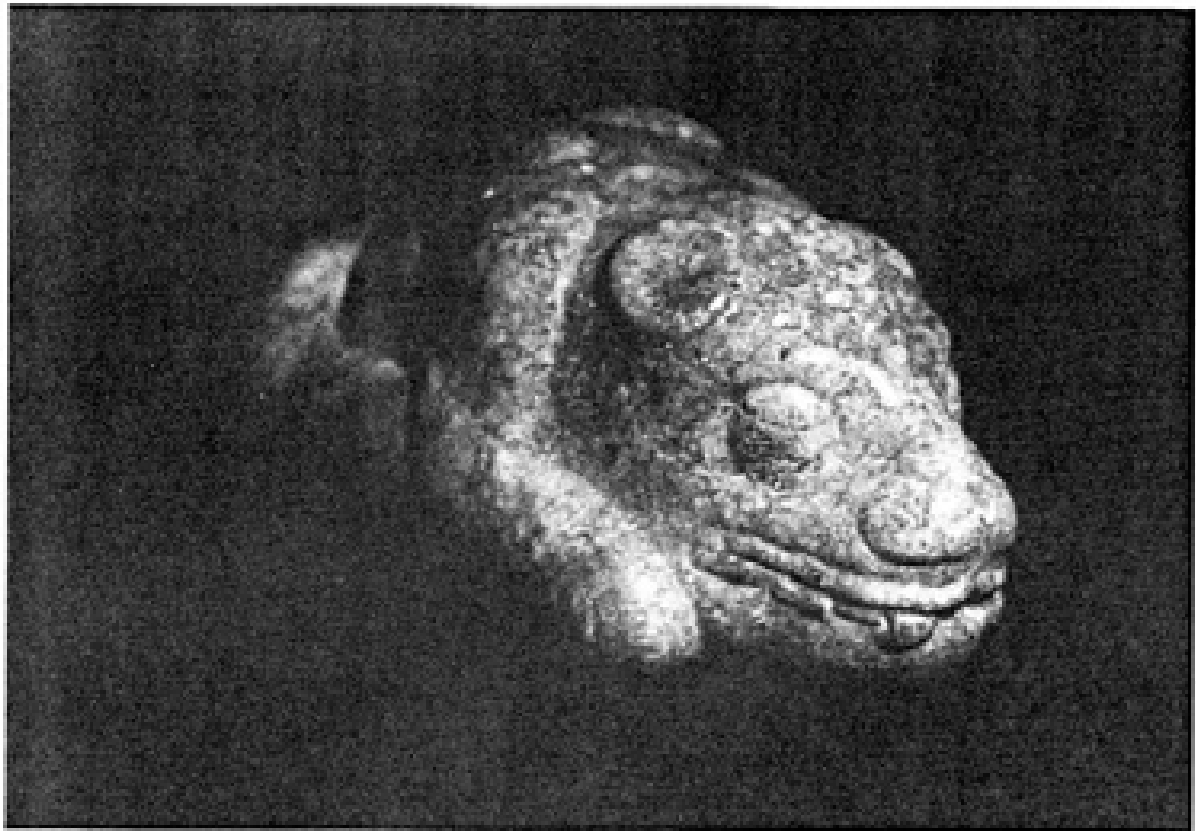
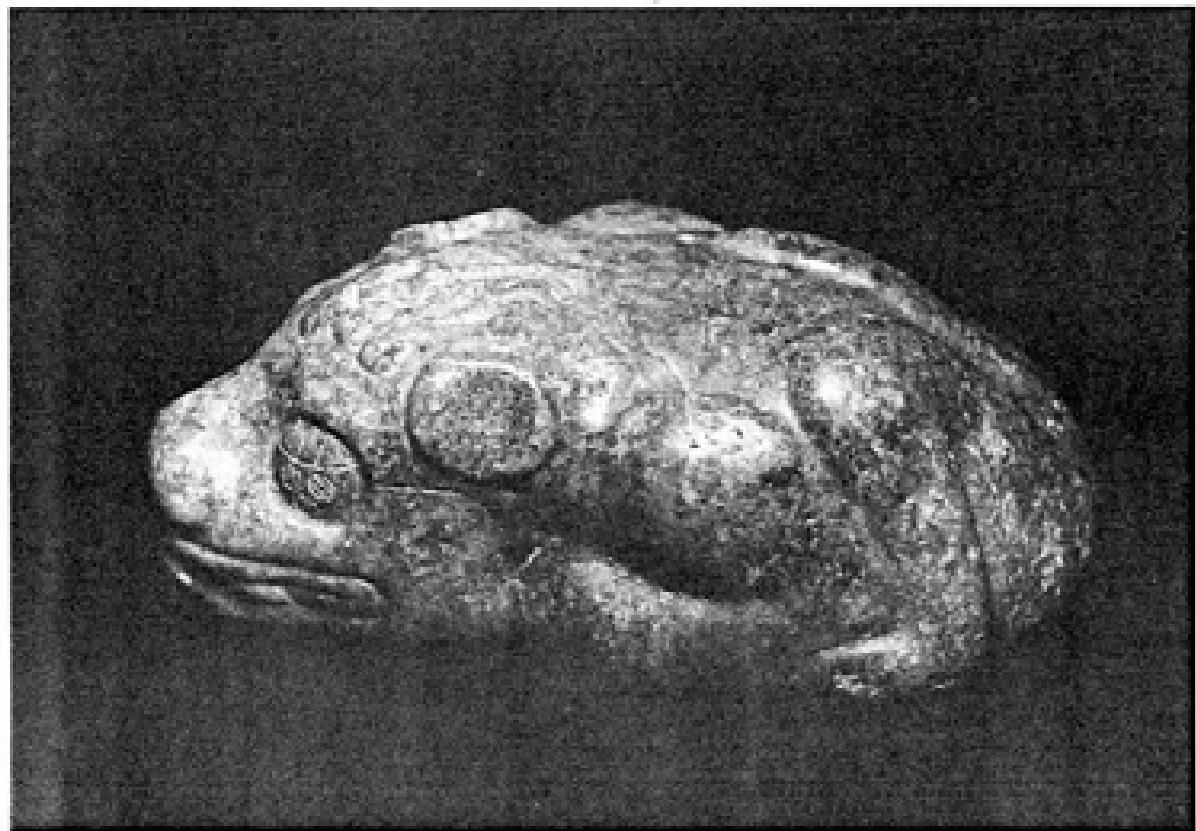
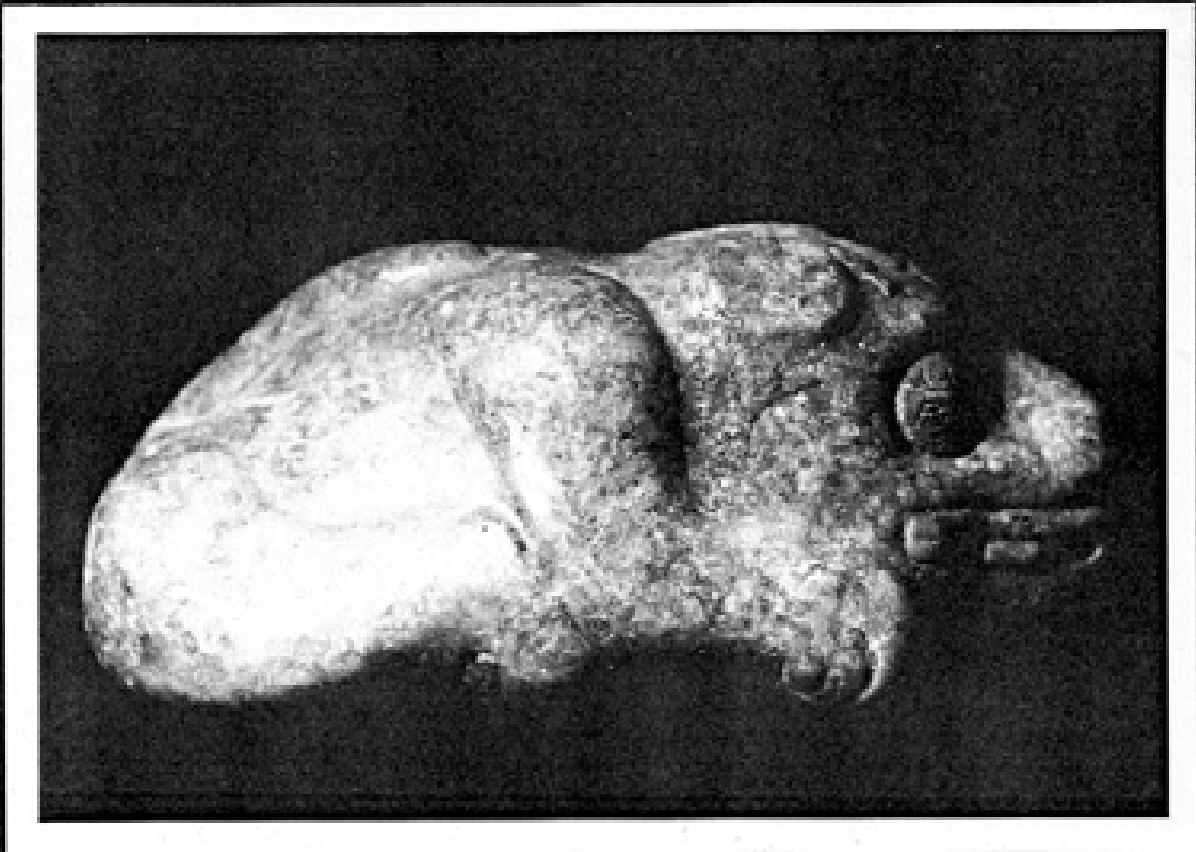

Photo 85 117A-50, the jade jaguar.





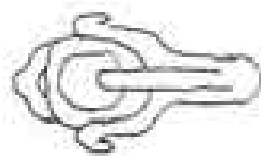

Fig. 81 Floral (?) motif on Jaguar's forehead.

dimensions are: length, 16.6; width, 9.6; and height 6.5 cm.; it weighed 3 lbs. 11 oz. The stone was not one color throughout but was a mottled light green (7.5GY-7/2 to 6/2). The color of the Kodachrome II photographs is its true color; the photograph of Kodacolor X (Photo 85, upper right) is too blue but shows the plant (?) between the ears and the variation of color. Over the jaguar, as well as under it, was sprinkled cinnabar.

The shape of the jaguar is lopsided, unsymmetrical, and the rear looks as much like a frog as it does a jaguar. This is a result of the great value placed upon jade with the consequence that the sculptor did not want to waste any more jade than he had to. Since jade is often found as a boulder or pebble in a stream bed, it appears possible that the stone's present shape was very much like its original shape with the jaguar features adapted to it.

That the creature is basically a jaguar is evident mostly from the Ix glyph in place of each eye. Ix is one of the Mayan days and its patron is a jaguar. Ix glyphs often occur as the eye of a jaguar (on the jaguar throne on Tikal Stela 20; right hand face on vessel from Bu. 169 (Coe, 1965, p. 49, p. 20) and (Ruz, 1958a, Fig. 8a, p. 90).

The second characteristic that hints towards its identification as a jaguar is the presence of a floral element on the forehead between the ears. From photographs it looks like some sort of water plant. Water lilies frequently issue

from the foreheads of jaguars (Bands, 1953, p. 108), and a motif similar to that on the Bu. 196 jade jaguar occurs on the forehead of the jaguar on Tikal Stela 20 (the Stela 20 jaguar also has ears and eyes similar to the Bu. 196 jaguar but a different nose).

The round ears on the Bu. 196 jaguar are similar to those on the Stela 20 jaguar but different from the standardized type with a curl that is usually employed. The nose shows up well in the photographs, but it is not of the double curl type often shown on a front view of a jaguar. Double-outlined, deep, straight mouths are more characteristic of serpents, especially Teotihuacan serpents, than of jaguars; but the features of these two sacred animals are often combined in both Mayan and Teotihuacan art. Not yet having made a comparative study of jaguar versus serpent teeth and not having a good drawing of the dentures available, the author is unable to suggest the possible origin of the method of depicting the teeth. For the legs, it is possible that an attempt was made to include some of the attributes of the frog or toad; but, more likely, the shape of the jaguar is the result of the natural shape of the stone.

The Jade Mosaic Vessel Plan #51 117A-51 Photos 86, 87, 88, 89

Only one other example of jade workmanship exists to rival the jade mosaic vessel found on the south side of Bu. 196;



Photo 86 Offerings on the bench.



Photo 87 Jade mosaic vessel as found.

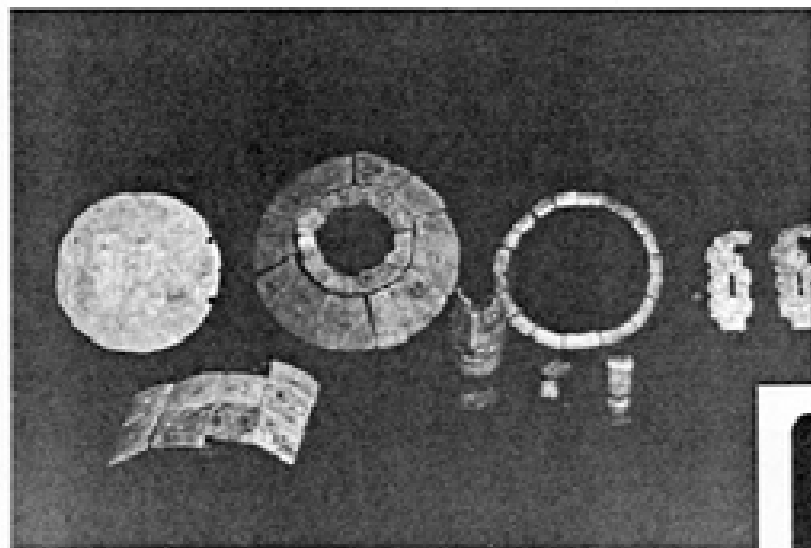
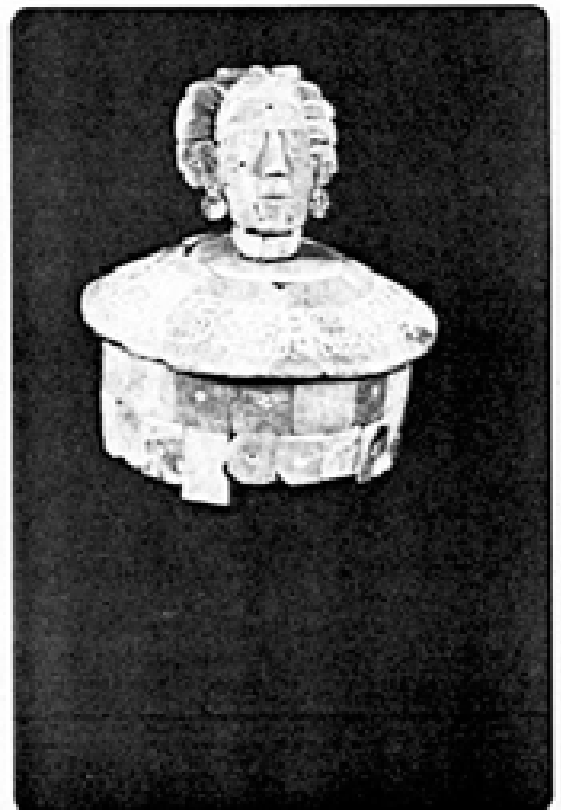

Photo 88 Jade mosaic vessel partially reconstructed.

Photo 89 Partially reconstructed jade mosaic vessel from Su. 116.



and that is a similar vessel from Bu. 116, Temple I. The Bu. 196 container has not yet been completely reconstructed or catalogued; so, the following description is based on field notes. As it was found, the vessel had apparently been knocked over while it was still intact; then, as the wood core rotted and the pressure of the collapsed walls increased the vessel was squashed and the mosaic pieces separated from one another.

The jade mosaic was built around a wooden core. The walls of the vessel were attached to the thin wooden backing (of indeterminate thickness) with white adhesive, traces of which were found on the backs of almost all the pieces of jade, and by some sort of "nail". The "nail" holes were covered with fitted plugs. The head, likewise, was fitted around a piece of wood. How close the shape of the wood was to the outside shape of the face is unknown.

The vessel consisted of the following basic parts, the first of which was a bottom made up of six pieces of jade, thicker than the jade used on the sides. One of the pieces was reused, as it had an incised decoration on its interior face. The edges of the base were beveled to receive the sides. All the bottom pieces fit together very easily and may be seen in Photo 88. The circumference of the bottom was not round but polygonal, each side corresponding to a column of jade that rose from it to form parts of the side wall. The author was unable to determine whether there had

been a wooden base over the one of jade.

The next part of the vessel was the sides, made up of approximately 100 rectangular pieces of fitted jade. The exact side height is unknown but it was probably near 10 cm. The color of the pieces varied as did their size. The largest piece was 3 x 4 x .4 cm.; average size was 2.3 x 2.3 x .3 cm., and the smallest piece not including several tiny slivers was about 1 x .7 x .3 cm. All the pieces were pierced at least once with a tiny hole which was always neatly plugged up with a tiny piece of fitted jade. All four edges of the side-pieces were beveled and the rear side was usually rough, often with a countersunk effect. About five pieces of the side had previously been part of carved or incised plaques and at least two of the pieces were part of the same original incised piece. The incised faces were on the inside of the vessel.

The third section of the vessel consists of at least two concentric circles of wedge shaped pieces with a human head rising from the center. The lid is not decorated with glyphs like the one from Bu. 116. The outer ring is a more or less perfect circle on the outside and consists of thirteen segments forming a raised plain. The inner circle of around 9 pieces has a diameter of about 5.5 cm. and is flat. A third and innermost circle is postulated to hold the neck in.

The fifth major part of the container is the head and its associated ornaments. Minus the headdress, the head is

about 6 cm. tall. It has earplugs consisting of a flare and a separate pendant in the shape of an inverted ahau; a necklace of minute tubular and spherical fragments, each pierced by a hole for stringing; a large ahau pendant of unknown location; and an elaborate feather headdress.

There is another element which may have been part of the headdress although it was not found near the head but by one side of the vessel and may have served as a handle. This element is comprised of two almost identical watery-like pieces each 5 cm. long. Surprisingly, each one is incised on both sides even though the two pieces were firmly glued together. The union of the two pieces was so well done that minute slivers of jade were used to lessen the unsightliness of the juncture mark of the two pieces.

Small pea shaped pearls were found under this vessel and were also found associated with the jade mosaic vessel from Bu. 116.

JADE WORN BY THE DECEASED

The jade worn by the deceased will be described from what he wore, head to toe.

Jade Headband Plan #58 117A-57a-n Photo 91

The figure wore a headband of 12 thin, rounded pieces of jade. The original order of the disks was ascertainable as all the pieces were relatively undisturbed by the collapse



Photo 90 Bu. 196, the skeleton.



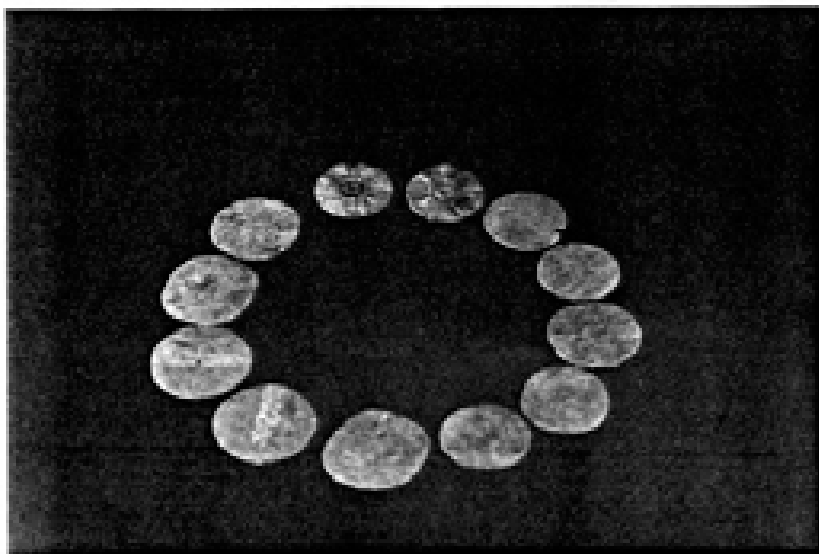

Photo 91 Jade headband.

of the tomb. Underneath all the pieces was the rotted remains of clothing, often with the weave impression still preserved. 117A-57a was covered with several layers of textile impressions and cinnabar. All the disks were centrally perforated; polished on both sides; and roughly round e and h were the most irregular with e almost squared off. The backs of the two central pieces were countersunk with the countersinking filled in with green colored "plaster". The fronts of f, g, e, h and the backs of all except f, g, d, and k have some groove, depression or irregularity. The front of a and l, the end disks, have a groove around the central perforation; outside the groove there is carved a radial petal design. The jade varies in color almost entirely within the range of 2.5G 7/ to /4 and /4 to /8. All the disks have veins and patches of brown and white; e and h also have some grey. The disks vary in diameter from 5.2 to 4.2 cm. and in thickness from .3 to .15 cm.

The ruler in Bu. 116 was wearing a headband of jade but the pieces were trapezoidal and not round. What may be head bands of round pieces of jade are shown on several rulers on stelae, and elsewhere (Ruz, 1952, Fig. 7, 13, p. 56).

Tubular Jade Bead with Carved Human Figures Plan #151 117A-62
Fig. 82a Photo 92

When the large shell over the skull was removed two objects were uncovered, a "Y" shaped pearl, perforated in sev-



Photo 92 Carved tubular jade bead.





Photo 92 Carved tubular jade bead, 117A-62.



Fig. 82A Human figures on the carved tubular jade bead.

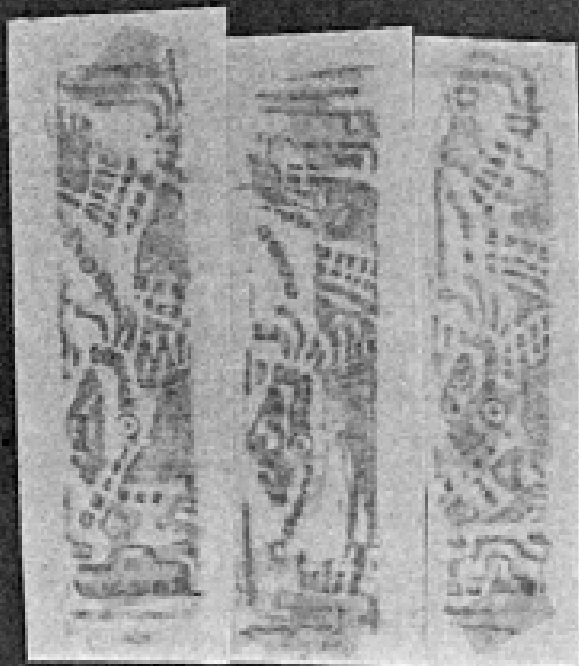

Fig. 82B Figure from Uaxactun pottery scene.

eral places and a carved, tubular jade bead. The jade bead was about a centimeter off the floor at the edge of the northwest part of the skull (slightly covered by the crushed part of the skull) under the shell to some extent, exactly how it lay with relation to the shell is not known because the jade was not noticed until the shell had been removed and some cleaning had commenced. The jade bead had cinnabar all around it, not just a powdery coat but a compact layer of brilliant red.

The bead is similar to those used on the necklace, with a lengthwise biconical perforation and a single collar at each end; and an irregular square in cross section. The ends of the bead are polished and have a circular depression around the perforation. Colorwise, it varies from 2.5G-7/4 to 6/4 with spots of 5/8. The jade is 8.9 cm. long and 1.9 X 1.9 in cross section.

There is a human figure on each of the four sides of the bead and each of the figures has his feet up in the air. Going around the jade the figures alternate positions, head to foot, seen only on a roll-out of the design. Two of the figures are standing on their hands; the other two are standing on their elbows on top of a glyphic element. Many people have suggested that the figure is supposed to represent the diving god. The problem with this interpretation is that the figure is seemingly almost 100% human with no supernatural

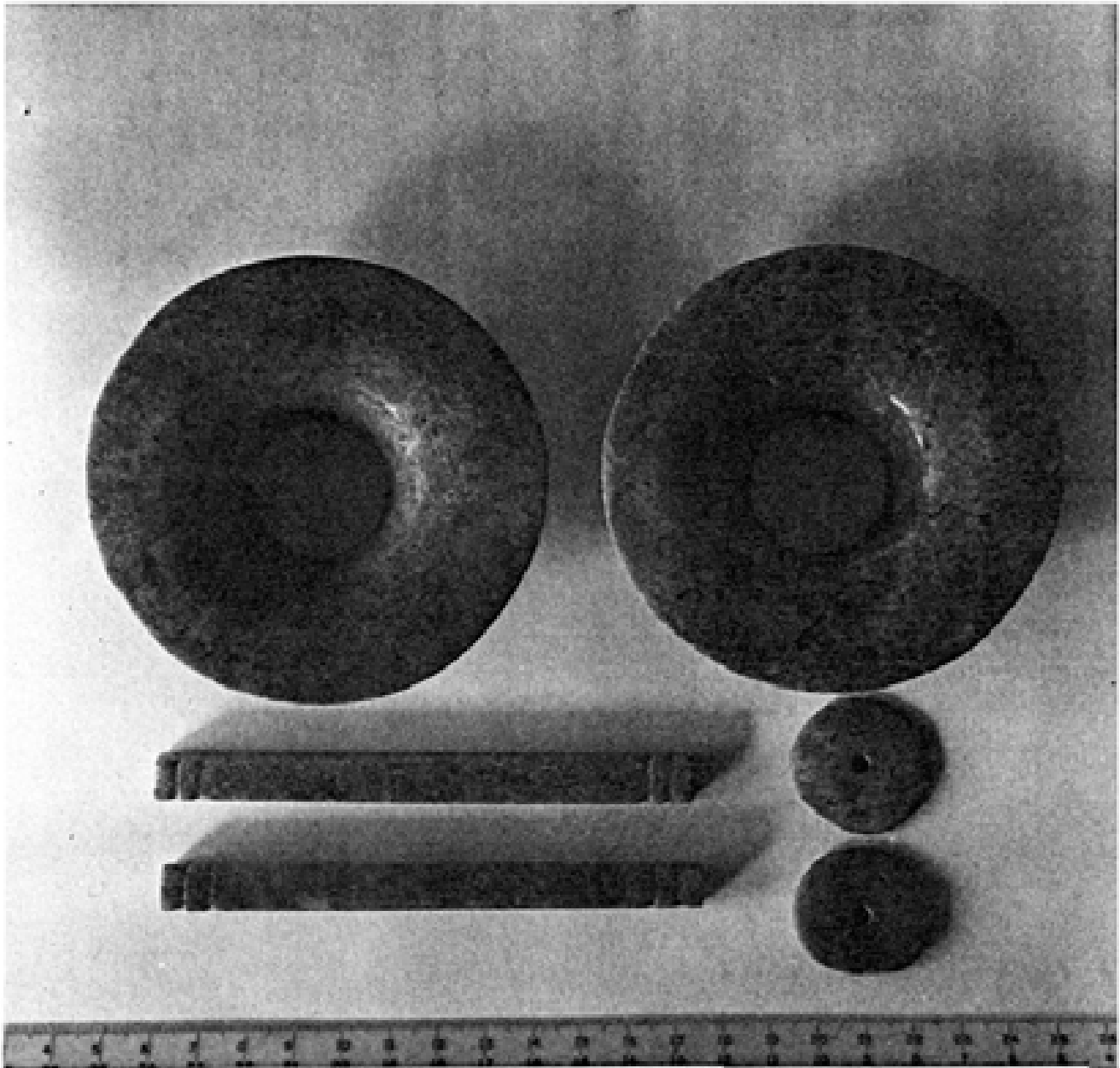
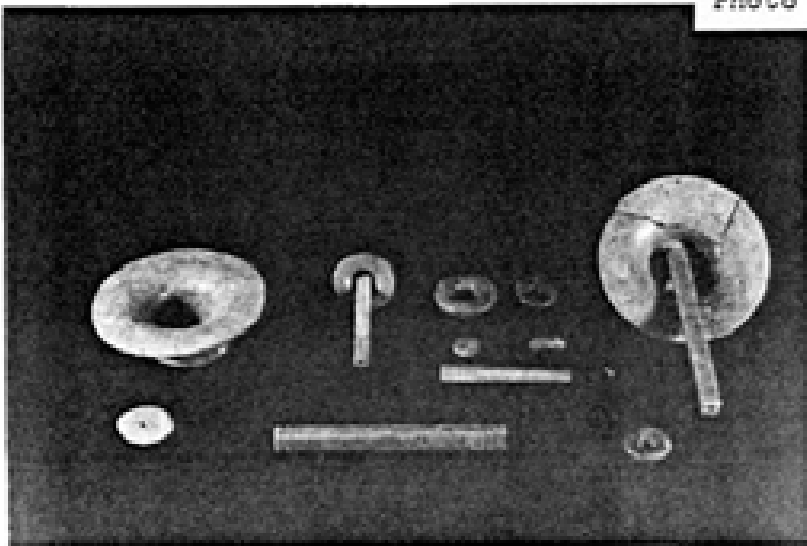

Photo 93 Carpius assemblages.



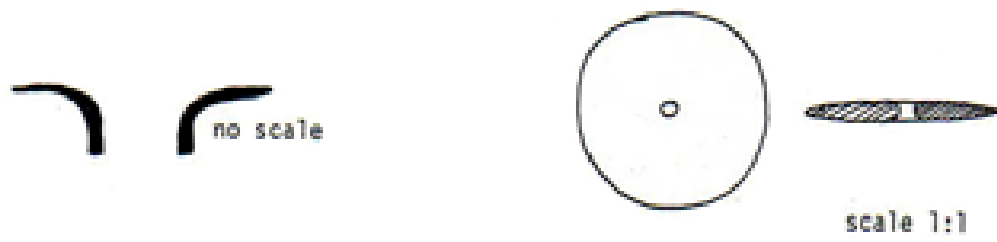

Fig. 83A Large earplug assemblage, 117A-52.

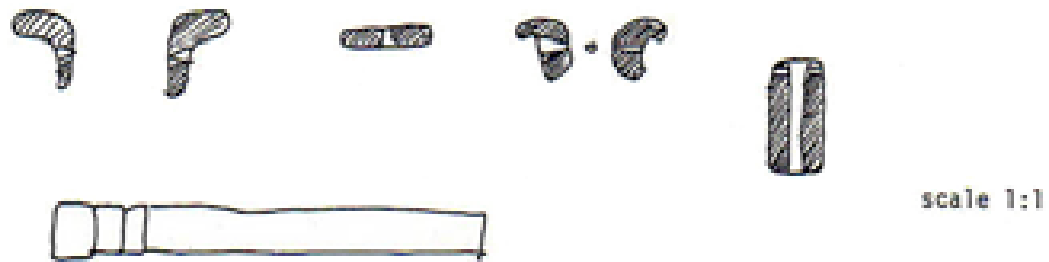

Fig. 83B Small earplug assemblage, 117A-66, -67.

attributes except his unusual position. A very similar figure occurs on a plate at Uaxactun (Fig. 82b) (A. L. Smith, 1934, Pl. 3). Here the figure is in a ceremonial context that may help identify its meaning.

Whether the bead was strung by itself, or as a back tie-piece for the jade or pearl necklace, is not known. Its close association with a "Y" shaped pearl suggests that the jade belonged with the pearl necklace.

Large Earplugs Possibly Belonging to a Headdress Plan #60,
61 117A-52a, b Fig. 83A Photo 93

Lying about 20 cm. from the north side of the skull was a set of large earplugs. Their position, some pieces scattered and some pieces on top of one another and two of the pieces 4 cm. off the floor; plus the fact that the ears of the deceased already had a complete set of earplugs still next to the ear suggested to the excavator that the large earplugs belonged to a headdress which had rolled off when the tomb collapsed.

Each earplug assemblage consisted of at least three elements: a flare, a disk for the flare, and a pendant. The flares are almost perfect circles and appear to have both been cut out of the same piece of jade. The stem was slightly off-center, met the flare at a noticeable angle, shows the marks of drilling and was unperforated. The ends of the stem are rough and show marks of cutting; in fact, the only really

finished surface is the flare face which is even and highly polished and covered with cinnabar.

The pendants are long and tubular, almost square in cross-section with two grooves at each end filled with cinnabar, and 11.2 cm. long with a cross section of ca. .85 x .9 cm. The color matches that of the flares (ca. 2.5G-7/2, 6/2 slightly mottled greyish green) but slightly brighter green, ca. 10GY-7/2, 6/2, spots of 4/4 and all highly polished.

There are a large number of spherical jade beads in the vicinity of the earplug assemblage and it is possible that at least one was used as a tie-piece or pendant at the end of the rectangular pendant.

Earplug Assemblage Plan #59 117A-66a-e 117A-67a-e Figs. 83

Thoroughly mixed in with the multitude of pieces of the jade necklace were parts for a jade earplug assemblage. Fortunately, some of the pieces of the assemblage were specially shaped and distinguishable from the necklace, but some of the pendants were of similar shapes.

Each earplug set consisted of a minimum of five pieces: two flares, one with a throat disk; and two pendants; there may have been at least a sixth piece because for the north (right) ear there was a perforated pearl in the correct position to be a tie-piece for the end of the large pendant (Fig. 83). Luckily, the earplug pieces of the assemblage were still

in their original positions, with the pendants still in or on the flares, etc. It appears that the large flare and pendant hung from the front of the ear while the other set hung below from the rear of the ear.

Measurements, in Centimeters (1st right, then left)

Flare:	H.	1.3,	GD	3.3	2.5G-6/6	
		1.1,		3.4	2.5G-6/6	
Small	H.	1.0	GD	2.2	2.5G-5/8, 4/6	
Flare		0.9		2.3	2.5G-5/8	
Throat	D	1.35	T	.3	10GY-4/4	
Disk		1.4		.2	10GY-4/4	
Long	L	6.5	Max	.8 x .7,	Min .65 x .4	2.5G-8/6, 7.6
Bead		6.6		.6 x .6	.6 x .35	2.5G-7/6
Small	L	1.8	W	.9	T .8	2.5G-5/6
Bead		1.8		.9	.7	2.5G-5/6

Near the small north earplug were the remains of a wooden tube, clearly not from the tomb beams.

5 Stranded Jade Necklace Plan #59 117A-65 Figs.84, 85 Photos 90, 94

Going from one side of his head to the other via the chest was a beautiful example of the type of jade necklace shown on stelae. The necklace consisted of five strands of mostly tubular beads, all drilled lengthwise biconically, and many with additional holes. Seemingly above (as worn when the man was standing) was a pearl necklace in complete disorder (see p. 199).

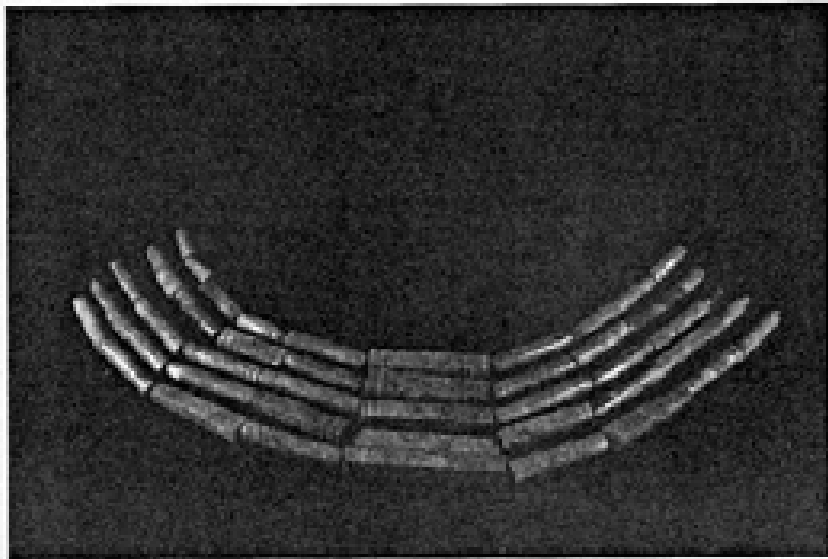

Photo 94 Jade necklace.



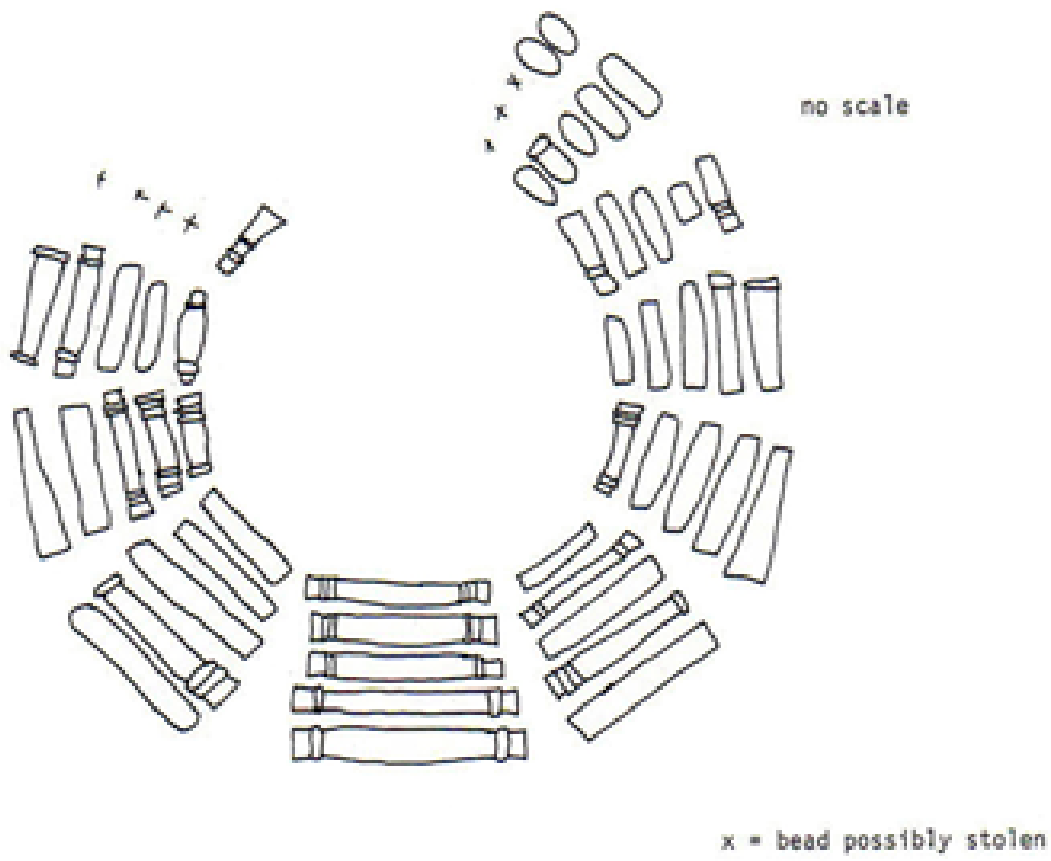

Fig. 84 . Sketch plan of the jade necklace.

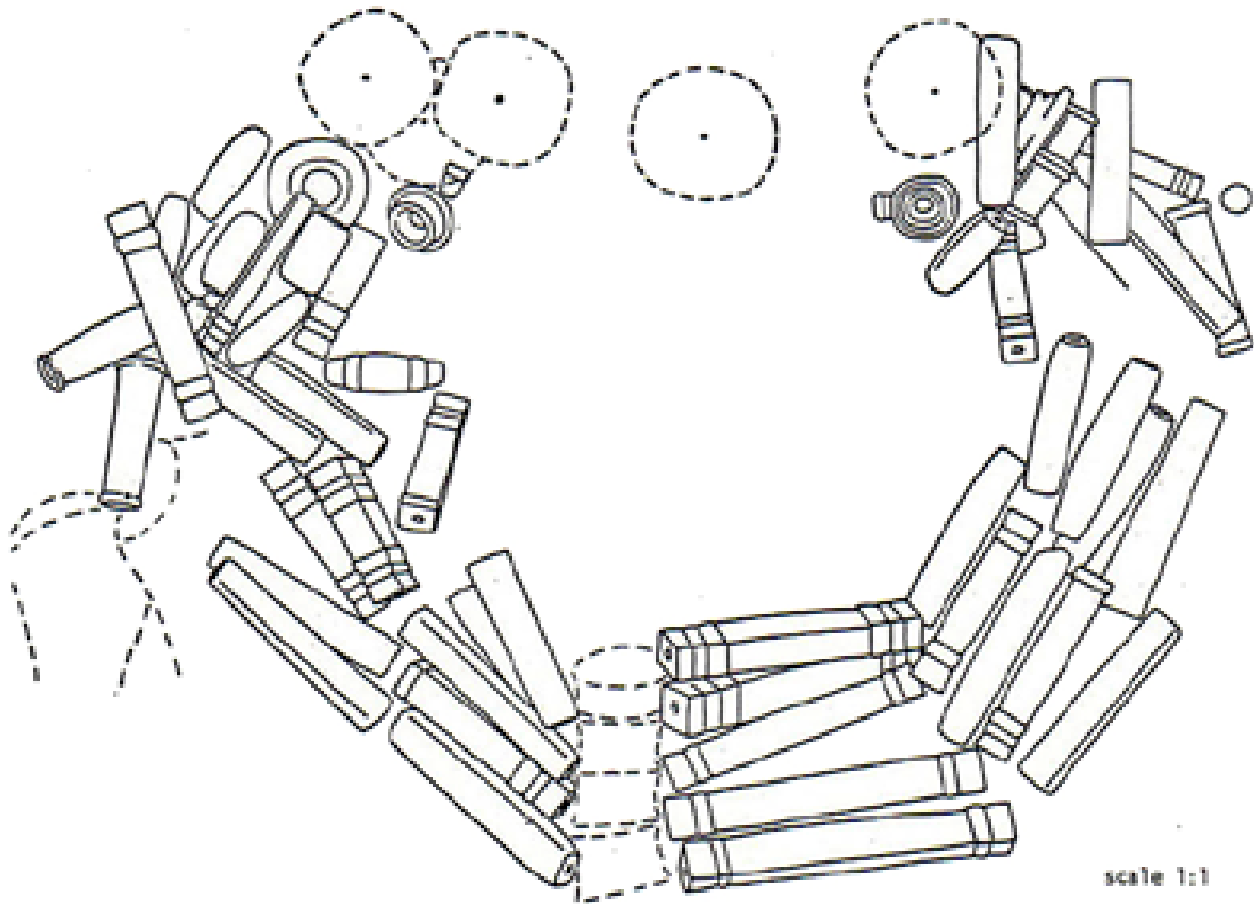

Fig. 85 Plan of the jade necklace as found.

There were at least nine groups on the five strands but the exact number is difficult to determine because the smaller beads by the shoulder were not in their correct positions relative to one another, but fallen amongst the shoulder blades and mixed in with parts of the earplug assemblage. An additional complication occurred when in December, 1965 someone smashed the lock on the tomb door and stole an undetermined number of pieces of the jade necklace. The number is undetermined because the necklace had not yet been completely excavated. The robbery happened the day after nine workmen had been fired and the first day of the Christmas vacation when all the workmen left camp.

Rather than include the measurements for each bead two drawings of the necklace and several color photographs are included to give the reader an idea of the size and shape of the necklace as a whole and the individual pieces.

The jade was not all perfectly matched and seems to have come from several locations. Mrs. Easby saw the jade in the tomb and pointed out a bluish piece that she thought came from the state of Guerrero, Mexico.

Over many of the pieces of jade were the clear remains of a cloth or hide with cinnabar on top. Under the cloth was a layer of rotted material. Under the jade were two or three layers of cloth (?); and under the cloth, over the bone, was cinnabar. The covering over the jade is believed to be the

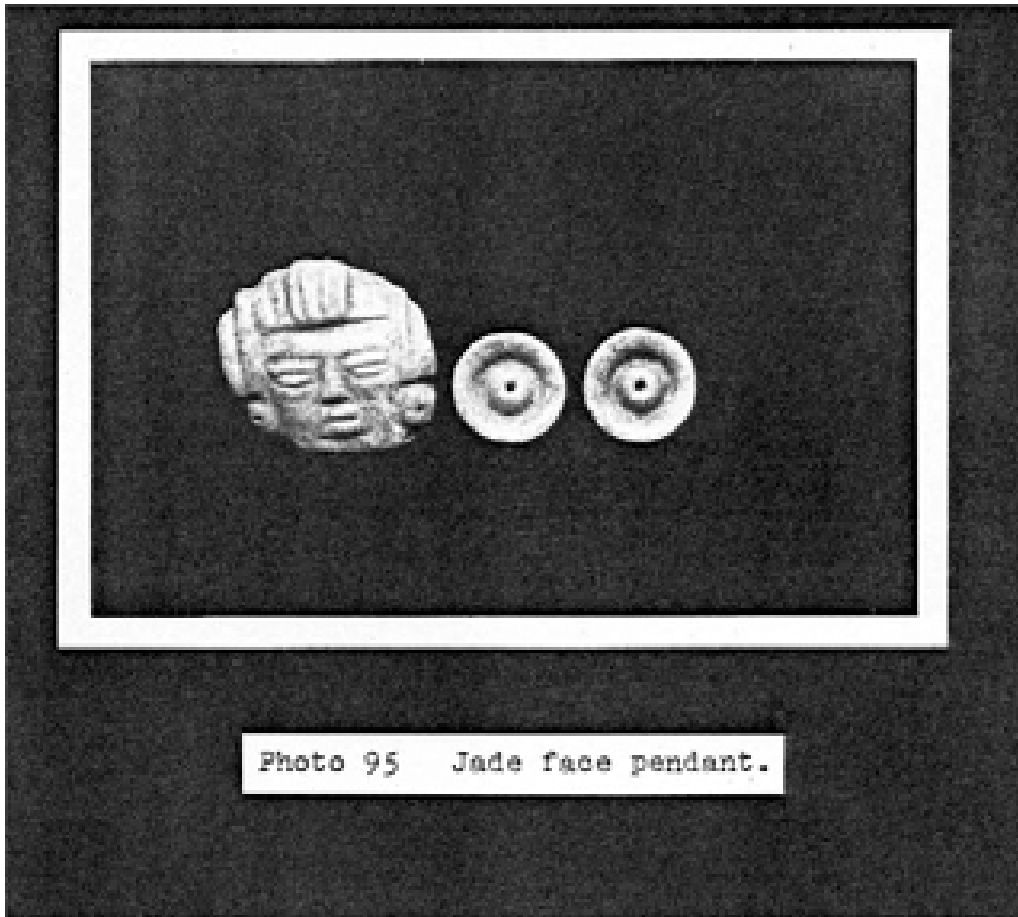

Photo 95 Jade face pendant.

remains of the cloth of hide which formed the burial bundle; the fibrous material directly under the jade may have been a mat which helped to hold up the jade (cf. notes on Bu. 116 where a similar material may have been under the jade necklace).

Carved Jade Face Pendant Plan #70 117A-58a-c Photos 90, 95

Face downward over the north (left) rib cage was a small pendant of jade carved on the front in the form of a human face with the bottom of the face to the west. Lying on the same rotted material as the face pendant were two "earplugs" which may have been associated with the pendant. Both "earplugs" were about 1 cm. north of the pendant. None of the pieces had any evidence of cloth over them.

The irregularly shaped pendant was seen by Mrs. Easby who said it was Early Classic in style. The shape piece suggested to the cataloger that the original lump of jade was worked with very little primary shaping. There is a biconical perforation crosswise through the head and three small biconical perforations along the lower edge, one just under the mouth and the others on the two sides the head near the earplugs. The pendant had a flat back and its polished surface bore traces of cinnabar. Its height was 3.1, its width 3.4, and its thickness 1.4 cm. Colorwise the head is 2.5G-7/2, 7/4 with veins of brown. The ear lugs are ca.



Photo 96 Jade offerings: top row, the earplug assemblages; bottom, from left to right: face pendant, jade in hand, carved tubular bead, jade penis pendant.



Photo 97 Jade face pendant; bottom left, jade held in hand; right, jade penis pendant.

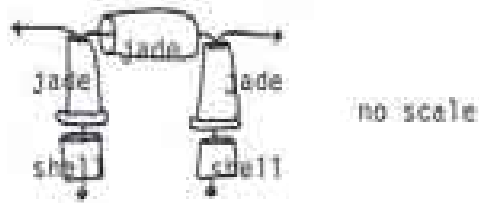

Fig. 86 Jade beads in the shell 'belt'.

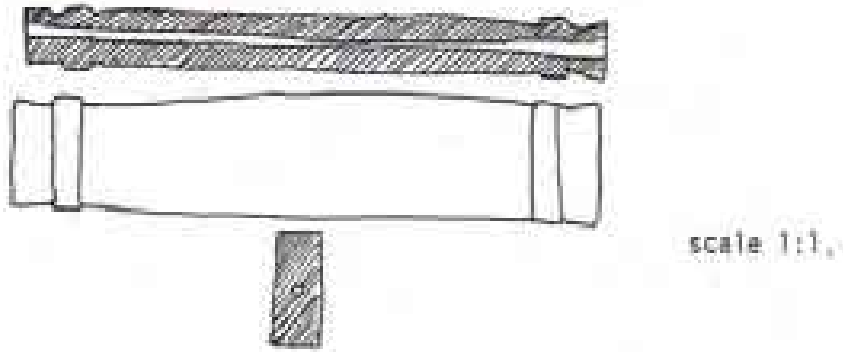

Fig. 87 Jade pelvic ornament.



Fig. 88 Tubular jade bead held in left hand.

10GY-6/4, 5/4 with a lot of brown.

The ear lugs have the appearance of being flare-and-throat-disk in one. The greatest dimension of both is 1.8 cm.; the jades were .5 cm. high and polished.

Jade Beads in the Shell Bead Belt Plan #72

Three tubular jade beads were part of the shell belt. These will be described with the belt on p. 196

Jade Pelvis Pendant Plan #75 117A-59 Fig. 87 Photo 96

A thin rectangular bead of jade was uncovered lying lengthwise between the legs of the skeleton resting on the pelvis; 2 cm. west of the east end of the jade bead was a tear shaped pearl, pierced for suspension near its top. Its proximity to the end of the jade suggests it was used as a pendant tie-piece. The jade lay on a carpet of solid cinnabar; below the jade and possibly above the cinnabar was what looked more like hide than cloth. The highly polished, single collared piece of jade has a lengthwise biconical perforation. The jade, of length 8.3 width 1.7, and thickness .75 cm. had rough and unfinished ends. Lots of brown marked the otherwise 2.5G6/8, 5/8 green.

Tubular Jade Bead held in Left Hand Plan #73 117A-61 Fig. 88 Photo 96

Underneath the left (north) hand at approximately the

middle joint was a tubular jade bead. Unfortunately the author was not able to determine whether the hand was palm up or down. There were fragments of what looked like a cloth stretching from over the leg bone, over all the finger bones, and of course over the jade where it was visible between the fingers. The jade itself stretched north-south with cinnabar under it and with specks of cinnabar and some rotted material over the jade and under the cover cloth. East of the hand there was cinnabar over the cover cloth.

The jade, with a single collar at each end, is an irregular rectangle in plan and section. The grooves around the collar still had cinnabar in them. The 1:1 drawing of the piece above is 7.5 cm. long and 1.4 cm. wide. The color varies with most of the patches 2.5G-6/4, 6/6 with a lot of brown.

Objects in Right Hand Plan #77 117A-64, -82 and -83a

There are no drawings, close-up photographs, or field notes currently available to the author concerning the three objects that were under (?) the finger bones of the right hand. The three pieces were: a flattened, spherical jade bead with a short groove along one side, greatest dimension 1, height .6 cm.; a small, roughly spherical spondylus bead, GD 1.2, H 1 cm.; and a bilobed pearl whose broken top may have perforated.

Photo 98 Jade wristlet minus shell pendants.

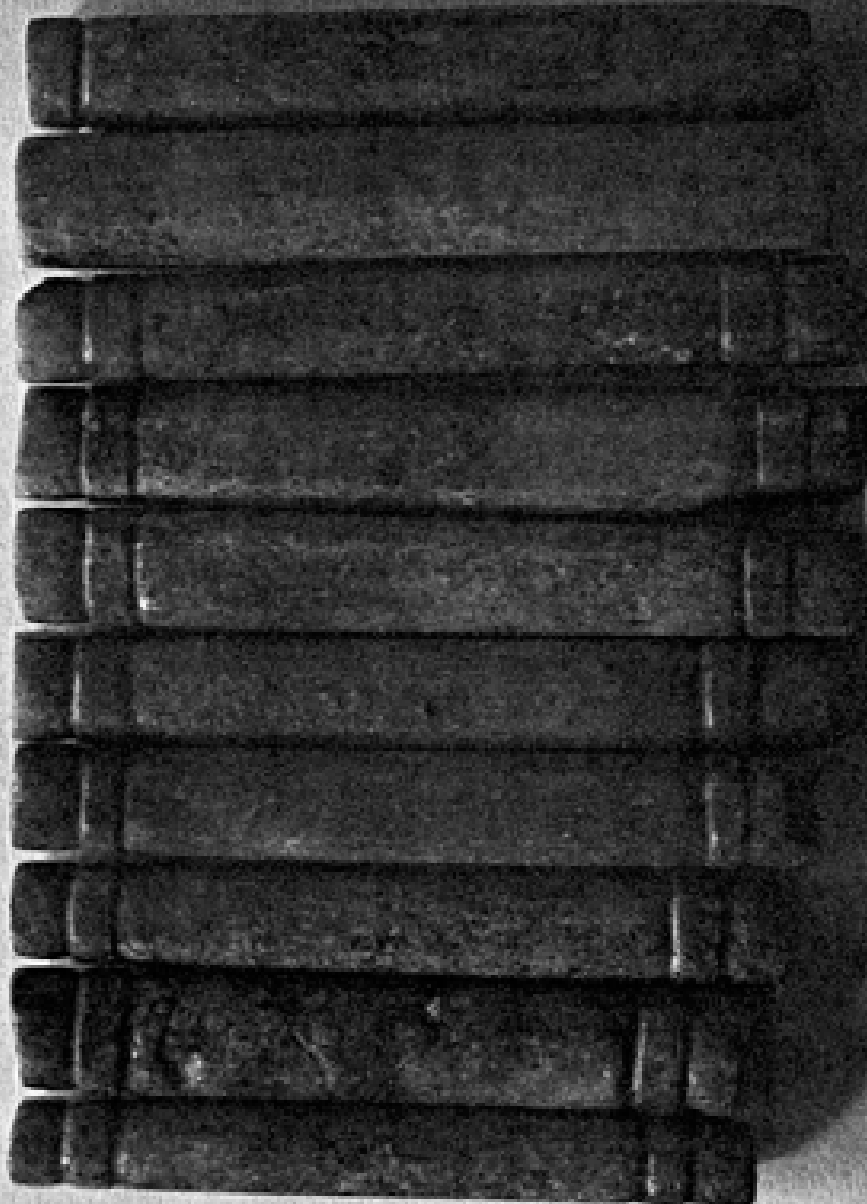

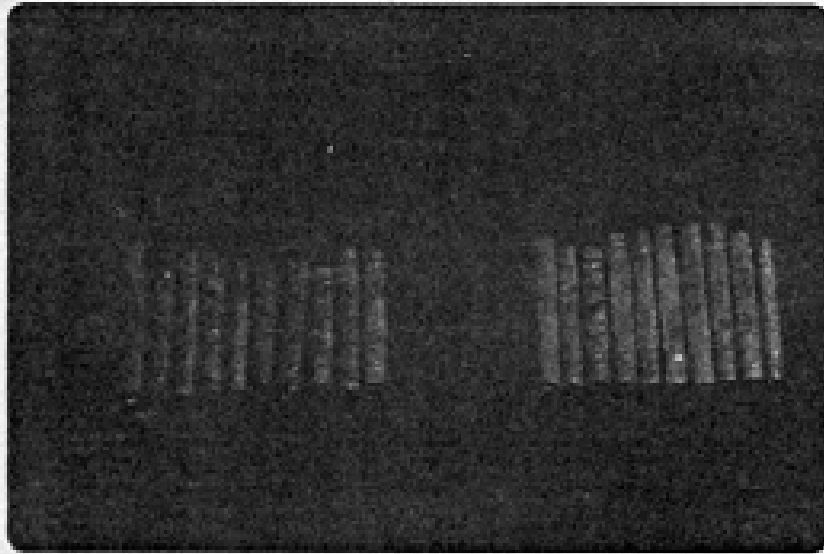

Photo 99 Jade wristlets minus shell pendants.

Jade Wrist Bracelets with Pendants of Fitted Shell Plan #'s
48, 49 117A-53, -54, -55 and -56 Photos 98, 99

The deceased was interred wearing jade bracelets of the type commonly shown on stelae and pottery (the throne figure on 117A-2 has the same kind) (Fig. 71). Each wristlet consisted of 10 tubular jade beads best seen in the photographs. There were no traces of cloth or hide between the jade and the bone but it appeared there had been a cloth over the right bracelet. Over the left bracelet was even more cloth. All the beads had sunk into a deep layer of cinnabar and rotted material which in one place went, from top to bottom: 117A-55d, cinnabar, thin layer of brown rot, and finally a thick layer of dark brown rot.

West of the jade beads were about 46 pieces of shell, the fragmented remains of pendants of an approximately elongated spherical shape. The pendants were too broken and compressed together to reconstruct more than a few.

Almost all the side pieces were pierced at the tapered ends and these ends were to the east toward the jade beads to which they were attached. They were, however, not individually lined up with the jade pieces with which they were associated. The pendants that were reconstructable showed that an individual pendant consisted of from 9 to 5 pieces of shell. Forming the sides and jadeward end were pieces with a curved end; the bottom was usually a pentagonal shaped piece.

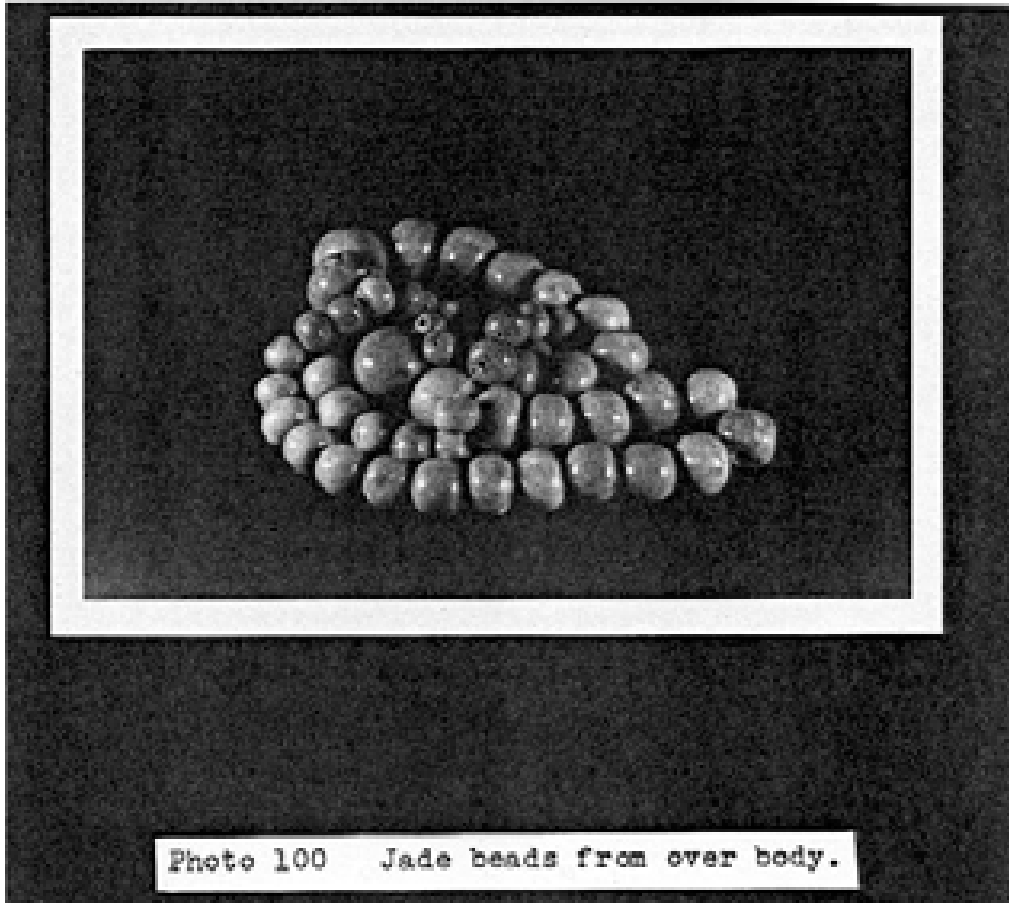

Photo 100 Jade beads from over body.

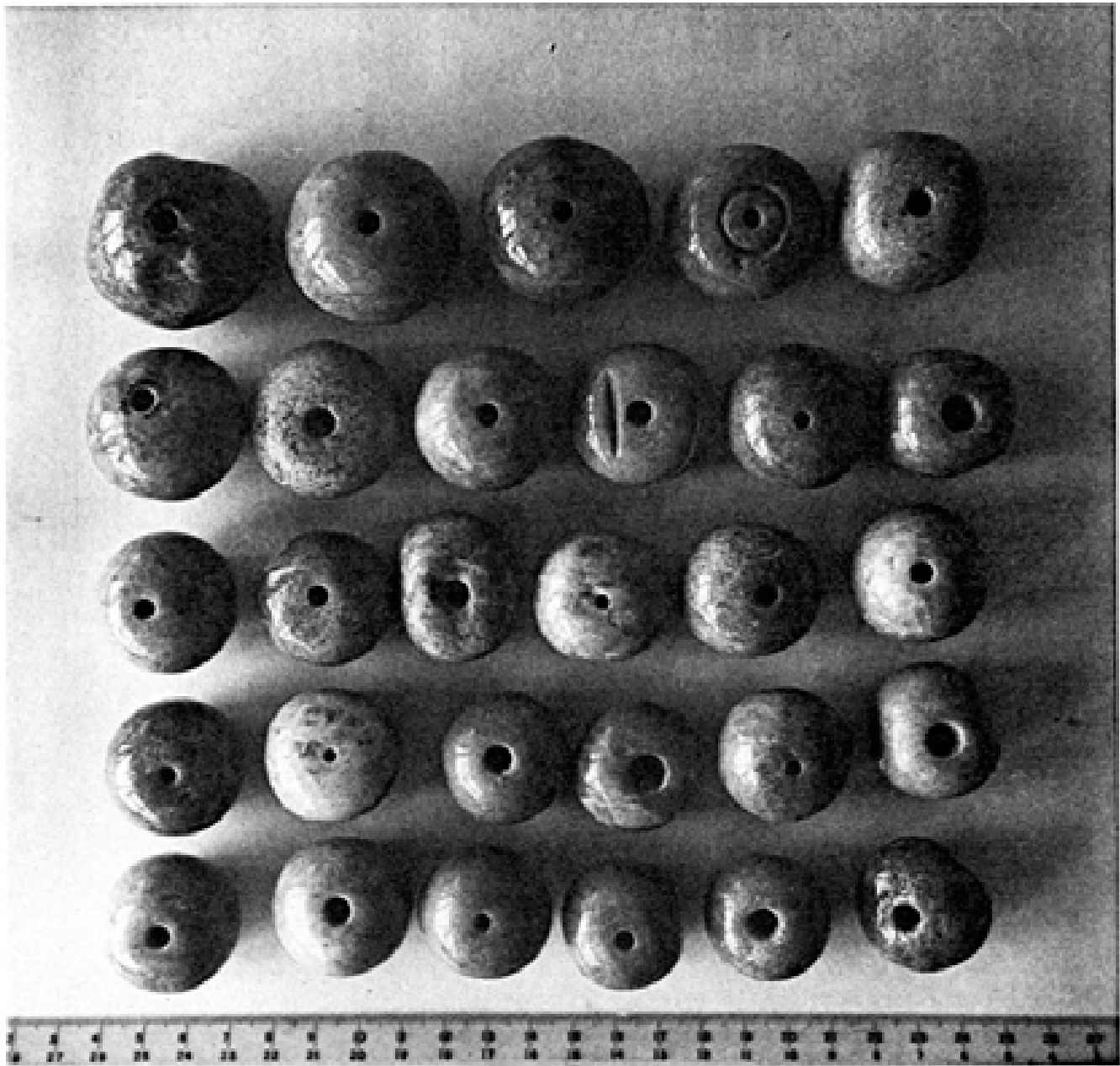

Photo 100. Jade beads from over the body.

Spherical Jade Beads Scattered Over the Body Plan #'s 105 to 150 117A-63 Figs. 42, 89 Photo 100

Sixty-one spherical beads of jade of all sizes were found over and around the body. At first no pattern or explanation could be put forward for their original position-- it appears that many of them had rolled, five landing in the aisle. The beads varied considerably in size with the smallest concentrated on both sides of the skull. They did not appear to have been pendants for the jade wristlets, nor were there enough near the ankles to suggest that they had been anklets. There were not enough altogether or in the correct position to suggest that they originally belonged to a collar such as the one laid over the body in Bu. 116. Because the beads always occur in the vicinity of the spondylus shells and because in Bu. 116 some of the spherical beads were clearly unassociated with the collar and were adjacent to the spondylus shells the author believes that most of the beads were connected with the shells in both tombs. In Bu. 196 some of the beads may have belonged to parts of the headdress but there was usually at least one spherical jade bead for each of the 26 spondylus shells. One flaw in the jade-shell theory is that there are no jades in close proximity to shells #93 and 94 at the foot of the skeleton.

The greatest dimension of any bead was 3.7 cm., the least dimension .9 cm. The relative sizes and colors may best be seen in the photographs. At least one of the beads



Photo 101 Bu. 116, Temple I showing placement of shells.

was stolen along with part of the jade necklace when the tomb was broken into.

Most of the beads lay on rotted material over 1 cm. off the floor and were coated with cinnabar. Some of the beads lay on top of a cloth or hide and none of the beads had evidence of cloth over them which indicates that they were on top of the bundle enclosing the body.

OFFERINGS OF SHELL

Spondylus Shells Associated with the Spherical Jade Beads Plan #'s 78 - 104 117A-70 a - aa Figs. 89 Photos 12

Just as the skeleton of Bu. 116 was covered with spondylus shells so was the skeleton of Bu. 196. Twenty-six shells were carefully placed over the hide or cloth that covered the body. Near the shells were usually one or more spherical beads of jade, just as in Bu. 116. All the shells had their ends facing west; all the shells were pierced near their tops; none of the shells seems to have had cinnabar in them (?); and the shells were symmetrically arranged. Burial A31 at Uaxactun (A. L. Smith, 1950, p. 97) has numerous sea shells, several obviously in bilaterally symmetrical positions, and several with tiny jade beads in the near vicinity.

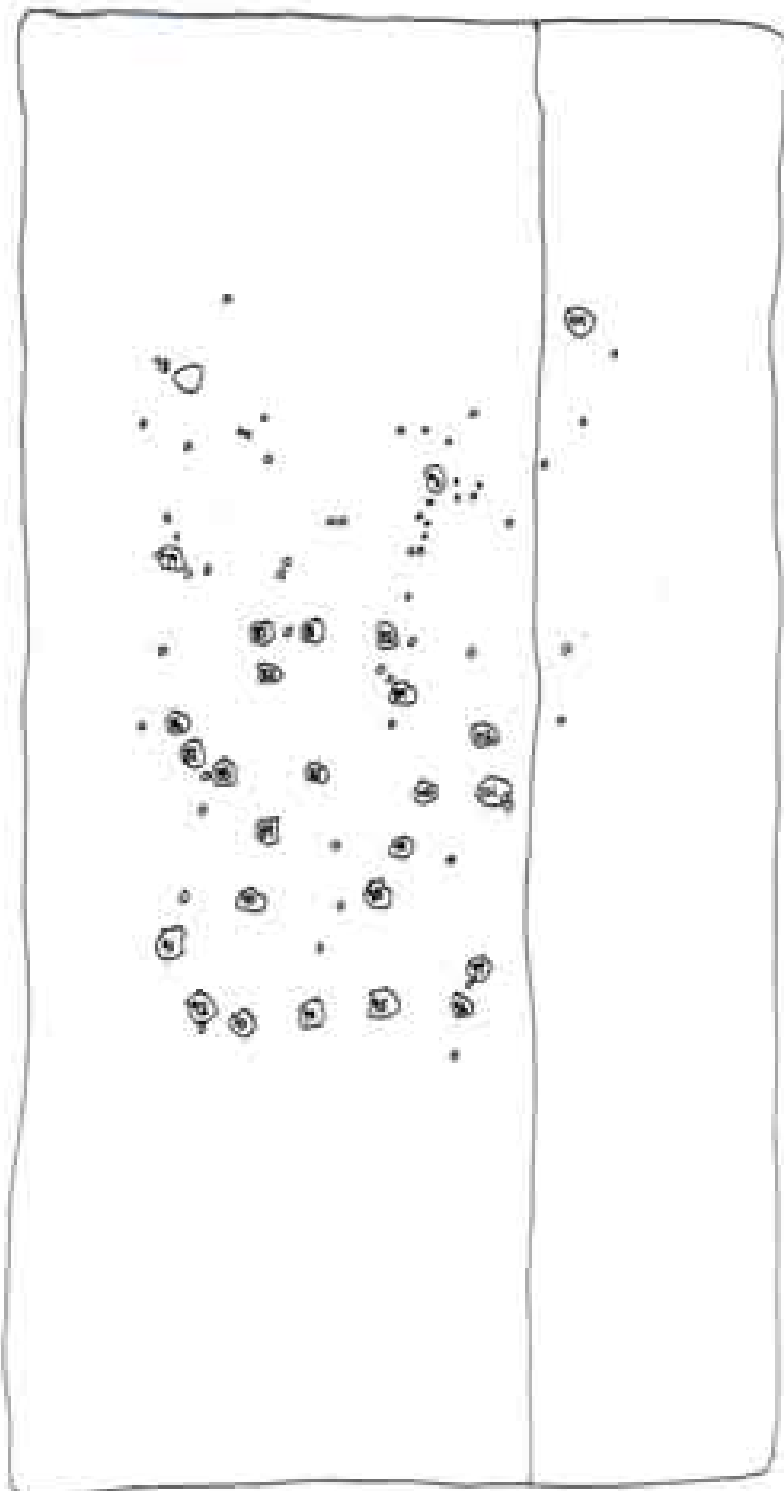

Fig. 39 Plan showing location of spondylus shells and jade beads.

South shell		North shell
# 78	=	104
79	=	103
80	=	82
83	=	84
81 is the central one of 80 - <u>81</u> - 83		
86	=	102
87	=	101
88	=	100
85 is the central one of 86-87-88- <u>85</u> -100-101-102		
89	=	99
90	=	98
91	=	97
92	=	96
93	=	95
94 is the central one of 91-92-93- <u>94</u> -95-96-96		

Although in many cases it is not possible to determine exactly which jade bead or beads was associated with a particular shell the following list is an attempt. Those beads that are of dubious association are designated by brackets ().

SHELL NO.	JADE BEADS
78	105 (106 to 110 inc.)
79	115 (113, 114, 116, Two (?))
80	118 or 117
81	117 (112, two (?))

SHELL NO.	JADE BEADS
82	135 (136 - 138)
83	119
84	134 (two) 132
85	?
86	120
87	121
88	122
89	129
90	128 or 127 with shell 98 completing for the two beads
91	123 (123 could belong to shell 90)
92	124
93	no bead except perhaps 127
94	no bead except 127 which must serve other shells
95	125
96	126
97	126 or 130 both of which are needed elsewhere
98	130
99	?
100	131 one of two beads
101	131 one of two beads
102	133
103	143
104	150

This leaves lots of extra beads around the headdress and a possible lack of beads for shells #91, 93 and 95, all at the bottom of the figure.

All the shells had their spines removed and their inside scraped down to some extent. The shell's insides were scraped and polished although some still had the white surface remaining. In many cases it was difficult to determine whether the single perforation (except for p which has two holes and possibly a third) in the hinge was natural or deliberately made.

Large Shell over Top of Head of the Deceased Plan #57 117A-69
Photo 90

Shiny side down, with its biconically pierced end to the west, there lay a large spondylus shell over the head of the deceased. The placement of a shell in such a position is a common Classic burial trait, being found at Piedras Negras Burial 5 (Coe, 1959, Fig. 64, 3); Uaxactun, Burial A6 (A. L. Smith, 1950, Table 6); and in several burials at Tikal, among them Bu. 116 in Temple I.

The end of the shell was deeply embedded in cinnabar and was covered with some kind of cloth. In one place the covering was well enough preserved to see a weave pattern. Under the shell and on top of the cinnabar was some white material- like brittle foam rubber. It is possible that this was merely fallen plaster. The shell, broken by the weight of



Fig. 90 Shell pendant, 117A-72.

collapsed debris, was 16 cm. long and 17 cm. in its greatest dimension.

Ovid-shaped Shell Pendant Plan #71 117A-72 a-d Fig. 90 Photo 90

East of the jade face pendant lay a nacreous shell, pierced for hanging with the pierced end to the west. Interestingly, the shell lay on top of a hide without any traces of cinnabar visible on the shell. The bottom of the multiple section pendant was a single piece. Lying on it was one large piece and 14 smaller ones, only the largest of which could be positively attributed to the bottom stylistically, although they were all found together. The large intact bottom section has the following measurements: D .2, L 9.5, max. W 6.2, and max. T .5 cm. The main fragment of the upper half of the pendant had been carefully cut and incised to depict a fish, with the mouth and fins still intact. There were 14 other smaller pieces of cut shell which could not be fit together to form a coherent design.

Shell Pendants for Jade Wristlets

These shell artifacts are described along with the wristlets on p. 190.

Belt of Spondylus Shell and Jade Beads Plan #72 117A-79 a-d Fig. 86 Photo 102

Over the waist there had been a belt of about 19 pieces

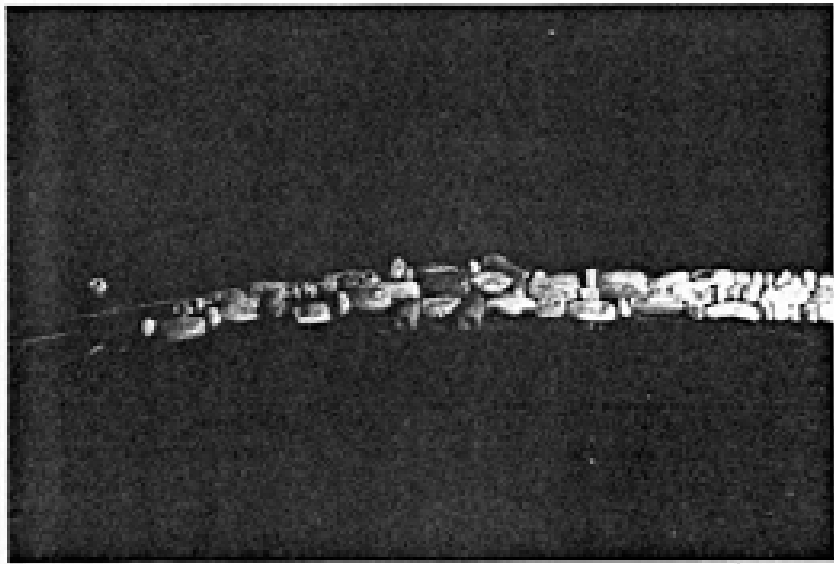

Photo 102 Belt ? of shell and jade beads.

of spondylus shell beads and three jade beads. The original arrangement of the beads was difficult to ascertain because most of the beads had either fallen amongst the bones or had collapsed in a tangled piece on either side of the backbone. One thing that was ascertainable was that the jade pieces had been a center decoration and that it was possible that the shell beads had been in one or two strands wide and that the small beads had been placed between the large ones (there were two distinct sizes of beads).

Two of the jade beads were identical, both being biconically perforated lengthwise, with smaller perforations crosswise at one end through which the beads may have been strung. The color is mixed 2.5 G-7/4 and 5/8. A third piece of jade may have served as a centerpiece. It was short and fat, L 2.4, D 1.4 cm.; perforated lengthwise biconically. Its brilliant green color varied from Munsell 2.5G-7/4 to 5/4.

The cataloger reconstructed the shell part of the belt as with three small beads between two large oval ones. Seen in the color photograph is all of the sequence that the author was able to reconstruct in the short time available to him. The number of small beads between the large beads may have varied. The largest of the two distinct sized beads are irregular in shape but generally with tapered ends, L ca. 2.5 GD 1.3 cm.; the other 65 beads are small and of a flattened-spherical shape, perforated biconically or conically. The largest bead is D 1.3, H 1 cm.; the smallest, D .8, H .4 cm.

Cut Pieces of Nacreous Shell Plan #68 117A-73 Fig.

Twelve small rectangular pieces of nacreous shell, uneven in shape, were found in the aisle next to the platform. From their position it appears that they were originally situated on the platform and fell into the aisle when the tomb collapsed.

Nacreous Shell Pendant Plan #56 117A-80 a, b Fig.

According to field notes the pieces of this offering were on top of one another next to one of the pyrite plaques. As two of the other three plaques had pearl plaques associated with them there may be some relation between plaques and shells.

The pendant consists of two cup-shaped pendants cut from nacreous shell but the cataloger thought that one of the pieces could have been made from half of a large tear shaped pearl. Piece #a is complete with a single hole at the upper end. The second piece is fragmentary and only partially reconstructable. Perplexingly, not all the pieces fit together, indicating that there may have been an appendage of some sort.

Shell Pendant Plan #66 117A-81 a, b

Similar to the pendant described above was another pendant which could have been cut from either a pearl or a shell. It lay under one of the large earplug flares that had belonged to the headdress.

Pearl Necklace Plan #67 117A-84

On the plan the pearl necklace is mistakenly shown as only occurring on the south side of the neck. In reality, there were pearls for a considerable arc around the head of the deceased. Most of the pearls were mixed with the upper strands of the jade bead necklace or were west of the jade necklace altogether. Whether the two were strung together or separately is not known. Because the pearls fell into the crevices between bones and jade beads, their original order was lost. Altogether, there were about 137 pearls of various shapes and sizes: pear-shaped, spherical, bilobed, elongate, and irregular. The largest specimen was L 3, W 2.3, and T 1.5; with most having a diameter of 1-1.5 cm., and all were perforated with one being incised around one side of the hole. The buried noble in Bu. 116 had a pearl necklace also.

Cataloged with the pearls was one large shell bead, flattened and spherical in shape. The author cannot say much without seeing the piece but it is possible that the shell bead belonged to the belt and became mixed with the pearls by mistake.

MISCELLANEOUS OFFERINGS

Incised Stingray Spines Plan #24 117A-85 a, b Photos 103

As the excavator was clearing fallen debris away from the skeleton, George Guillemin suggested that a search be made



Photo 103 Stingray spines

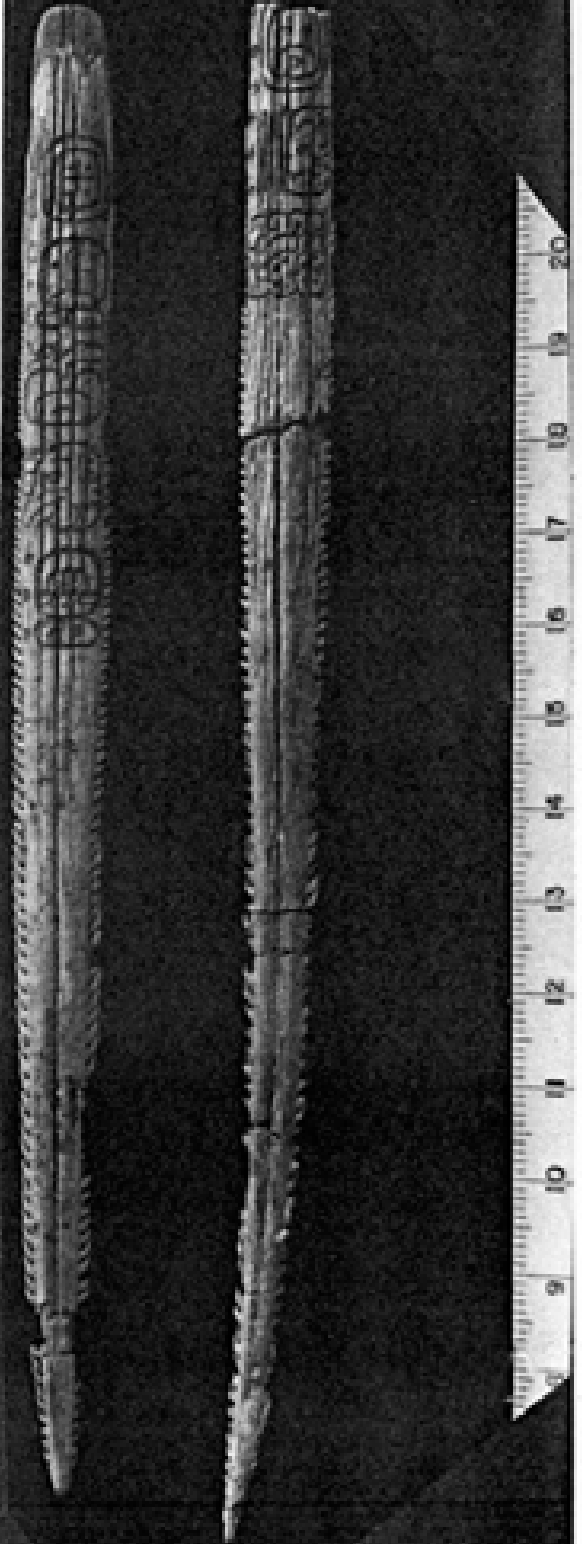

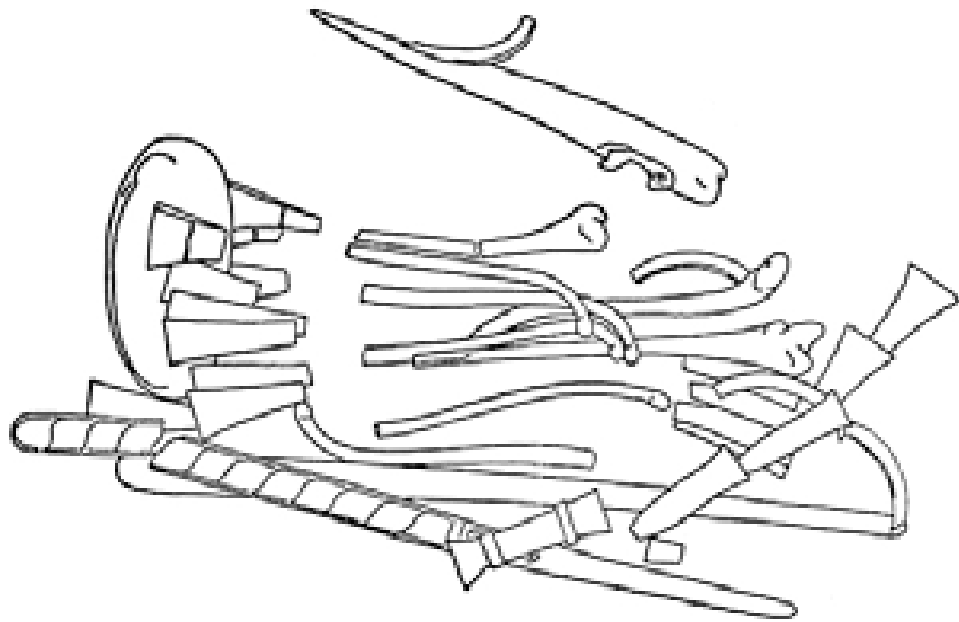

Fig. 91 Pile of bone and shell objects.



Photo 104 Group of bone and shell objects.

in the vicinity of the pelvis for stingray spines. Surely enough, they were soon found; lying on the pelvis with a tubular jade bead between them. The spines were covered with hide, rot, and cinnabar with the cinnabar very thick both above and below. Beneath the cinnabar under the spines was several millimeters of dark brown rot over the floor. There was a possibility that there had been a covering over the spine below the cinnabar but preservation was not good enough to determine this point for sure. Both spines lay with their incised glyphs up. Stingray spines are a frequent occurrence in the pelvic region at Uaxactun (Smith, 1950, Table 6).

The Glyphs

Each spine had glyphs incised on the upper portion. The 3 Ahau spine was missing its top portion and there were probably more glyphs on the missing section. There was no trace of the missing part in the tomb. The glyphs are very hard to decipher because of the nature of the surface of the stingray spines, which is marred by lines running lengthwise, due perhaps to aging.

Jaguar Paw Bones 117A-88

About 72 paw bones of a feline were found in approximate groups of five in 16 locations (thus making four or more hides). The bones were not always well preserved and as they were the last objects to be removed from the tomb they had

suffered from repeated cleanings by often being swept out of position. On the plan the paw bones are shown but are not given numbers. It was not possible to determine whether the paws came from jaguar hides which were worn by the deceased or were used to cover the body or form a bundle.

PILE OF BONES AND SHELLS

East of the large pyrite plaque next to the south wall was a conglomeration of shells, bones, and teeth. During excavation, before any of these objects had been spotted, that something was below was indicated by the sudden occurrence of a layer of compact white material very much like soft marl. There was nothing on the walls of the tomb of which it could have been a part. That this was an intentional deposit is indicated by the fact that it only occurred over the pile of bones and a few centimeters beyond (no further than 5 cm. away). Its original extent or depth is not known because most of it was brushed away before the bones began to appear with the excavator mistaking it for plaster of some sort. One large segment of the preserved material lay over the two carved-incised bones, preserving a perfect impression of the design of the bone.

Carved-Incised Bones 117A-86 a, b MT 180, 181 Fig. 91 Photos 104, 105

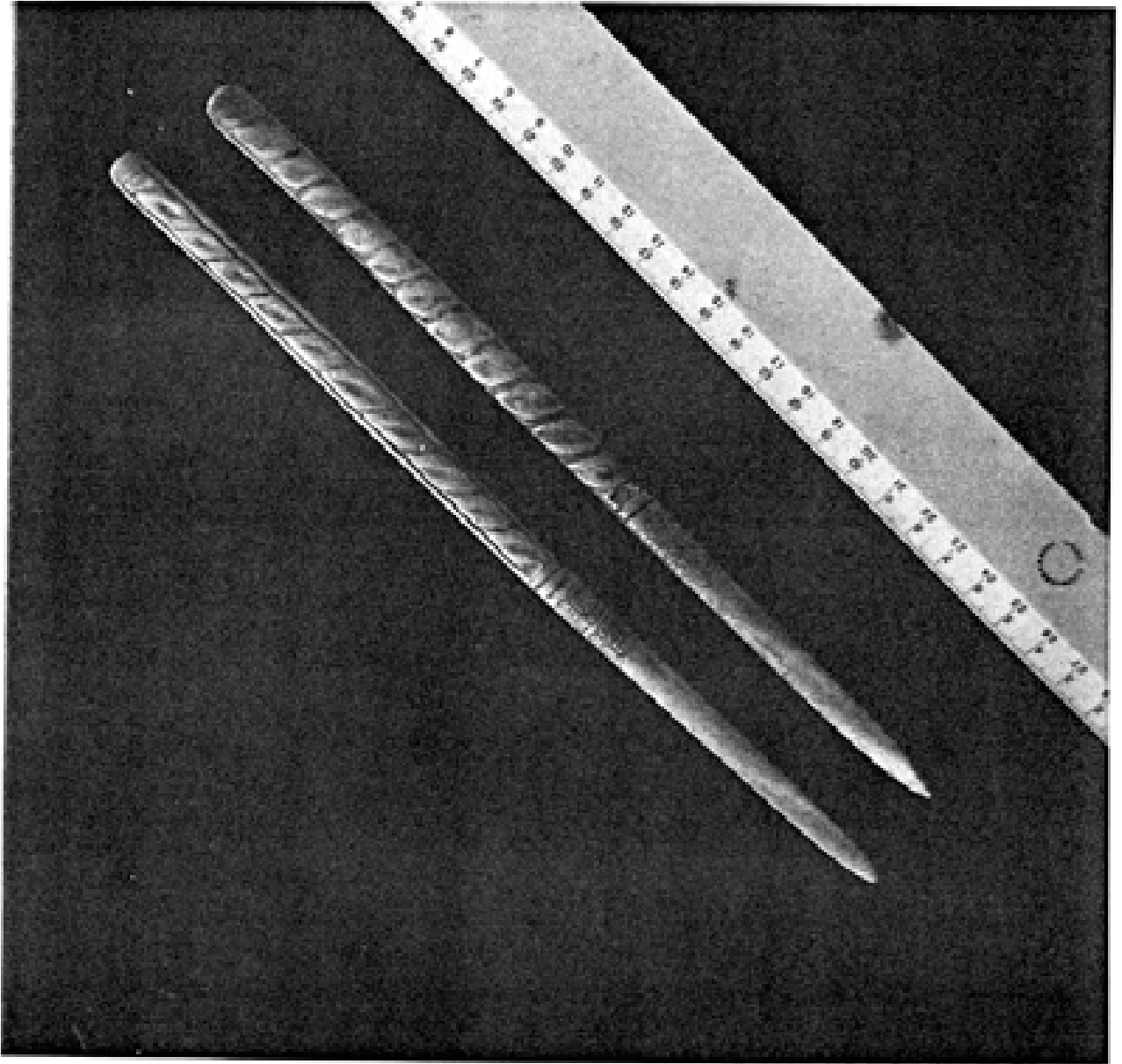
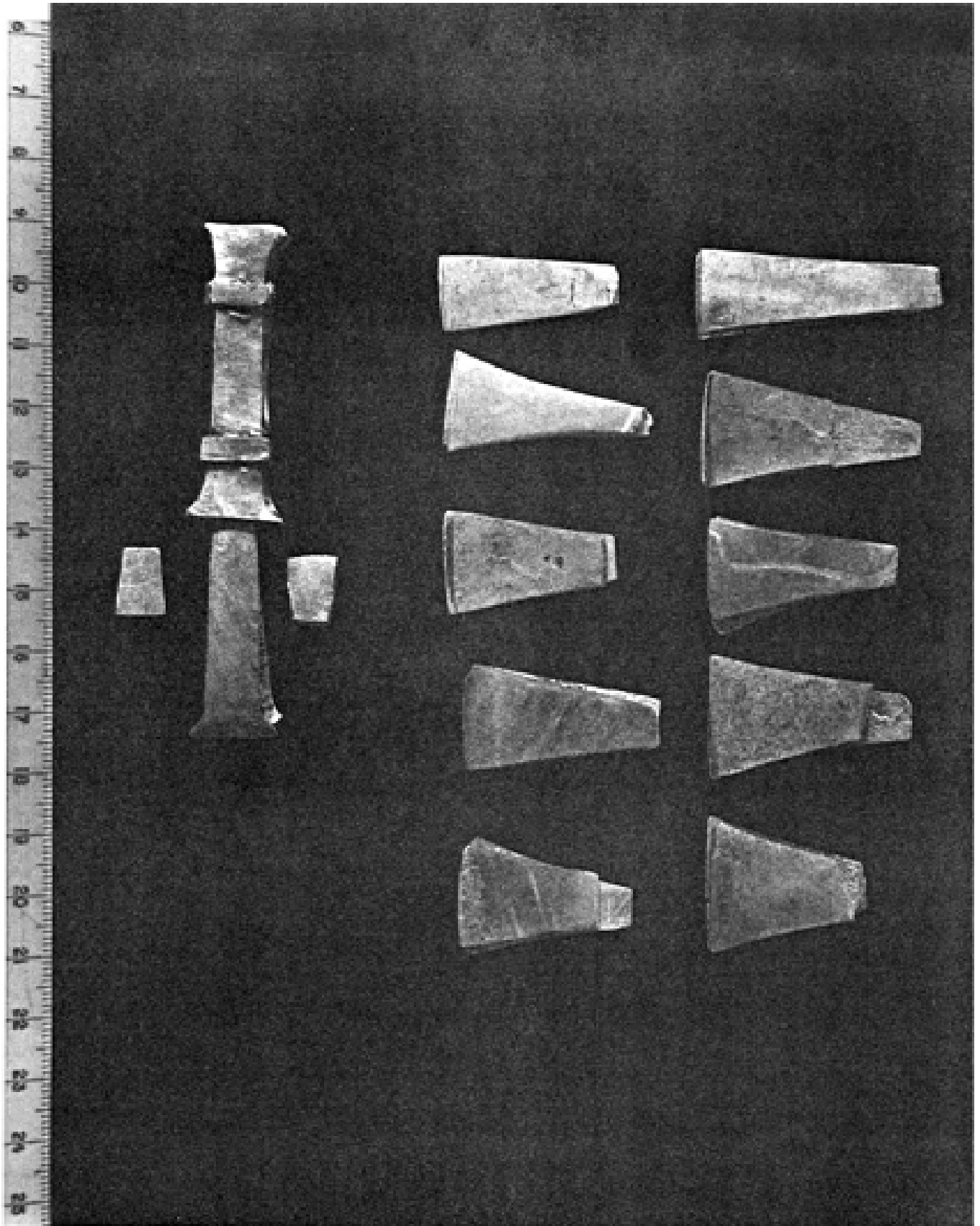

Photo 105 Carved-incised bones



Two bones formed the north boundary for the grouping. These were both carved on their upper portion with a twist design, with each bone being slightly different. The top of the bones were rounded off and curved up like a shoehorn. Below the carving were two incised glyphs whose flawless execution helps in their decipherment. Several centimeters on, the plain end of the bone tapers almost to a point.

As they lay, the upper of the two bones had the carved surface up and the lower bone had the carved face down in the bed of cinnabar on which both the bones lay.

The whole surface of the two bones was polished. The Tikal emblem glyph bone is 24.5 cm. long with ca. 13.7 cm. of carved surface. The other bone is 23.6 cm. long.

Shell "Tweezers" 117A-76 Photo Opposite page

Lying diagonally across the top of the uncarved end of the incised bones lay a "tweezer" handle of cut pieces of nacreous shell fit together with a white adhesive to form a rectangular solid with a collar at each end. One end does not have a shell piece but is filled with the adhesive and there is a small hollow where the tweezer ends were placed.

Next to the end of the handle was a pair of tweezer ends of nacreous shell, one of two pairs found next to the handle, and judging from their size and shape, those which belonged to the handle. On the interior of both were traces of adhesive.

Found near the tweezers and handle were two small cut pieces of shell which may have been part of the whole object, set into the handle. There were traces of adhesive on the interior of one.

Other Tweezer Ends 117A-77 a-j Photo Preceding page

Unattached to any recognizable handle were ten pairs of "tweezer" handles, each pair of a slightly different shape show traces of adhesive on the interior surface. All but h and i are of nacreous shell; h and i are of white shell. 117A-77J was not found with the other tweezer ends but had been placed next to the smallest pyrite plaque (see p.).

Olivella Shells 117A-75

Scattered throughout the group of bones and tweezers were over 150 tiny Olivella shells. They were so small that they were moved by even the tiniest brush. The unfortunate result is that any meaningful grouping of them was lost. All the shells, ca. .3 - .5 cm. long, had their spires missing; but this may have been a result of accidental breakage.

Unmodified Shell 117A-74

Lying with its long axis north-south was an unmodified freshwater clam shell (*Leptodon largillierti*) 8 cm. wide, 3.6 cm. high with its open surface facing up supporting the ends of some of the tweezer ends.

Worked Bone 117A-91 a, b Fig. 91

Two bones of similar shape lay in the east-west collection of bones. They were long bones of medium sized animals, the same bone from two different animals. The west end of the bones was intact but the shaft had been cut and the cut end tapered by two cuts of opposite sides of the bone. One bone was shorter than the other and had the cut end missing. L a: 12.5, b: 7.8 cm.

Bone (Perforator?) 117A-92 Fig. 91

Lying off to one side of the main concentration of bones was a flat piece of long bone of a medium-sized animal including part of the end. The whole bone was smoothed and polished on both sides though parts of the interior surface is still visible. The shaft is thinned and tapered with the resulting form looking like a letter opener, 14.4 cm. long.

Teeth 117A-89 a-f Fig. 91

Mixed in with the bone pile were six rodent teeth which, from size, appear to belong to at least four different animals. There are two pairs present and two single teeth.

Miscellaneous Shells 117A-78 Fig. 91

Mixed in with Field #35b were two small circular pieces of white shell with a circular depression in front, rounded edges, edges beveled toward rear, and a flat back. The exact

location in the tomb of this article is unknown.

Worked Bone 117A-90 a-g Fig. 91

Six rib (?) bones of an unidentified animal lay with their curved ends to the west. The bones all have one original end present and one, a, has the other end also, which has a perforation .35 in diameter. b-g have the corresponding end cut off and the interior appears to have been smoothed and filled with a white adhesive (?). All the bones were polished originally and have an average length of 8 to 9 cm.

Worked Bone not with the others Plan #53 117A-90g

A seventh bone was found in the vicinity of the group of three pyrite plaques. The bone was not noticed until all the plaques had been removed. Although it is possible, that this bone was accidentally moved during excavation is doubted.

PYRITE (?) PLAQUES

Four pyrite plaques were placed on the bench as offerings for the deceased. Three were together in the southwestern sector of the bench and the fourth and largest was located west of the group of bones.

Smallest Pyrite Mosaic Plaque Plan #55 117/A-93

This small round disk was found as a roughly circular

(13 cm. in diameter) layer of crumbly golden orange-yellow decomposed matter. On parts of the surface there was a thin layer of cream colored mold-like stuff. In one pie shaped area there was a dull red powder and in most places the yellow and orange disintegrated pyrite had dribbled over the edges, causing the irregular shape of the plaque as it was first discovered. The floor underneath the plaque was rough and pitted, probably eaten away by the sulphuric acid produced by the decomposition of the pyrite and the humid air. The pyrite had been in the usual mosaic form on the upper surface and the ridges of adhesive could still be seen.

The backing of the plaque was a thin disk of unidentified stone, perhaps not the usual slate. With a diameter of 10.2 cm. (and a thickness of .6 on the edges to .8 cm. in the center) this was the smallest of the four plaques. The edges were beveled slightly toward the plain side, which does not appear to have been decorated. Two conical perforations, GD .9 cm. pierced the plaque from the plain side.

There was an offering of shell in the vicinity of the plaque, a three dimensional shell pendant described on page 198.

Small Pyrite Mosaic Plaque Plan #54 117A-94

Next to one edge of the large wooden bowl was a pyrite mosaic with a diameter of 16 cm. The .6 cm. disk was badly

split and broken and the pyrite mosaic pieces almost completely disintegrated with the overall pattern not discernable. This, the only plaque that did not have a shell in the immediate vicinity, had the usual encrustation of decayed pyrite on it except parts of the slate backing was bare of encrustation as most of it had slipped or run over the sides. The encrustation on this plaque was a darker grey than that of other plaques which may indicate a different kind of pyrite as there was very little red coloration. Beneath the disk of unidentified stone there was no eating away of the floor but there was pitting where the floor was in contact with the pyrite that lay on the floor around the sides of the plaque. There was one piece of pyrite mosaic still preserved on the upper surface of the plaque indicating that this was the side with the shiny mosaic surface.

On the edges, beveled toward the plain side, there were traces of green stucco, but this did not seem to extend to the faces of the disk. Two conical perforations, GD .8 cm. pierce the plaque from the plain side.

Large Slate-backed Pyrite Mosaic Plaque Plan #52 117A-95

The easternmost of the three plaques was the largest, with a diameter of ca. 18.4 cm. The edges of the badly broken disk had a few traces of green stucco on them but there were no traces of stucco on the faces of the plaque. Unlike the

other two plaques, this one had only a single conical perforation through from the plain side.

Next to the west side of the plaque was a pair of handle-less "tweezers" (see p. 205).

Largest Pyrite Mosaic Plaque Plan #45 117A-96

Lying next to the south wall of the tomb was a pyrite mosaic plaque of the unusually large diameter of 34 cm. with stucco on the underside. When it was found its mammoth size suggested that its underside might be either carved or stuccoed and painted--this was the usual practice on other large plaques. As the only way to remove the plaque was to pick it up the author waited until everything had been removed from the tomb and then cautiously pried up one side (the disintegrated pyrite had somewhat cemented the plaque to the floor and it is fortunate that it did not break when the attempt was made to lift it). At once, painted stucco was visible and also the fact that some of the painted stucco had become cemented to the floor. As the excavator did not want to risk further disturbance, the plaque was left in the tomb until the arrival of the Project Director who suggested that the plaque be brought to the lab on the floor. So, a workman set to work to cut out a section of the floor and a large chunk of the floor was pried up, with the plaque still on it. Then, because a Jeep ride to the lab would be too bouncy, a litter

was constructed of scaffolding and the plaque was borne in style to the lab. Later, the cataloger turned it over and pieced together what was left of the painted design.

Because of the cover of protective chemicals, it has not yet been possible to take a photograph of the painted side or make a drawing. In general, the painted stucco on the edges and back was in very poor condition with only fragments of the scene remaining. The rim has stepped units in blue and yellow with red on green, inside of which is a red band with black horizontal chevrons. In the center, on a green background in red, yellow, blue, white, and brown is a standing figure on the left, wearing a loincloth and elaborate feather headdress (and probably originally lots more) and holding a fan (?). On the left seems to be a corresponding figure with red sandals and a white and red loincloth. Between them at the bottom are three large glyphs in a row. On top of the central one there is another figure of some sort. The figure on the left has a human form; that of the other two is indeterminate. There are lots of traces of painted feathers. The preservative has discolored the stucco somewhat, making the Munsell readings unreliable. All together there was: red, green, blue, yellow and brown.

On the north side of the plaque was a small pile of shells.

Pyrite Mosaic Plaques

There have been two excellent studies of pyrite mosaic plaques (K.J.S., 1946, p. 126) and (Woodbury and Trik, 1953, p. 232) and no more need be said here, especially since the author had to leave Tikal before the plaques were cleaned. The largest plaque recorded for Zaculeu was 24 cm. (Ibid., p. 236) and at Kaminaljuyu the largest was 25 cm. The largest plaque recorded for anywhere in the western hemisphere had a diameter of 29 cm. (Chichen-Itza, K.J.S., 1946, p. 133). With a diameter of 34 cm. the plaque from Bu. 196 is an unusually large one and a masterpiece of Mayan craftsmanship.

Stuccoed and Painted Wooden (?) Vessel Found Fallen From the Bench Plan #69 117A-97

The remains of a red and blue stucco-painted wooden (?) container were found mixed with debris fallen from the wall and pushed off the bench. Whether its original position was the bench or the aisle is not known (see p. 152).

Jaguar Hide (?) Plan #54

That there was a feline hide covering the body or worn by the deceased was indicated by the presence of the paw bones of a feline and in many places the traces of a hide-like unwoven material and on the south side of the body of the well preserved remains of some hide-like substance. That this material covered the body is suggested by its position,

relatively far from the body and clearly going up and over. This position is indicated by the remains of the hide where it has fallen back over some shells. Also, on the south side of the body there were many places preserved where the cloth turned over. Although the author thought while excavating the tomb that the hide had covered the body, evidence from other tombs supports this belief. In addition, over almost all of the jade body ornaments there was the trace of a hide or cloth. Under most of the shells, and over none of them, was a trace of a hide or cloth which showed that the shells, and the jade beads associated with them, had been used to "weight down" the bundle. The approximate limits of the cover cloth are indicated by dotted lines labeled #64.

Area of Gold Colored Residue Plan #62

Around the skull there was cinnabar and a trace of rot over the first layer of hide. Underneath the hide was a layer of several millimeters thick of dark brown rot. Below this was what looked like the remains of a golden-brown skin, forming a circle around the head, the circumference being about 15 cm. from the skull and with a very clearly defined limit. This layer is probably the rotted remains of part of the headdress.

Cinnabar

Traces of red paint were first noticed on the walls and

on the surfaces of some of the fallen wall stones. In one place on the wall there was a large spot of red where it looked like a sock-full had hit the wall, The scarcity of the red on the walls suggested that there was no deliberate attempt to scatter it on the wall and what did adhere to the wall did so by accident. In no place was there any red on any of the vault stones lending support to the theory that the body and offerings were placed in the tomb before the vault was raised.

The fact that there was red paint both sprinkled over the top of the jade jaguar and under it implies that some cinnabar was sprinkled over the bench before some of the offerings were put in place, yet there was no red beneath offering #2. In no place was there evidence that any red paint had been placed in the aisle. What red there was all fell over off the top of the bench.

There were several concentrations of cinnabar, one being in the pelvic region where the incised stingray spines were sunk deep into it, and under the left (?) hand; another being around the skull, and a third being immediately north of the pile of carved bones, under the massed bones. Cinnabar over the skull showed that the paint had been added when the body was in place, or that cinnabar had been added before the body was wrapped. There was no place where there was any cinnabar in the spondylus shells that lay over the cover cloth and most of the jade beads associated with the shells were lying

directly on top of a cloth or hide.

Basically the cinnabar does not extend very far away from the body, exceptions being a large area of cinnabar and hematite east of the feet, by the carved-incised bones. Between the feet and knee there was not much red coloration. In the near vicinity of the body the cover-cloth extended out further than the red, and the black and brown rot extended a little further. Usually it appeared that there was no cinnabar right next to the floor, i.e., under the ring of golden rot around the head there was no cinnabar.

DATE

On the basis of the architectural style of the pyramid and the artistic style of the pottery offerings the tomb and structure may be dated as Tepeu 2 (or Imix in the Tikal terminology). The exact date in years is more difficult to determine, but somewhere between A.D. 750 and 900 is probable.

CONCLUSIONS

In addition to the discovery of the tomb, the Str.5D-73 investigations showed that a major temple-pyramid existed in the center of Tikal without a masonry temple building on top. The complete significance of both the structure and burial may only be gathered after a comparison with other excavations at Tikal, a complete study in itself and outside the scope of this paper.

The real importance of Bu. 196 is that the immense quantity of offerings provides much material for comparative studies. Of great interest is the similarity between Bu. 196 and Bu. 116 in Temple I. This ties in with the similarity between the architectural design of the two structures and suggests a relationship between the two individuals buried. As Miss Proskouriakoff has demonstrated that some Mayan centers were ruled by dynasties, perhaps here at Tikal we have two burial monuments to two possibly successive rulers of the same dynasty.

BIBLIOGRAPHY

- Bullard, W.R.
1965 Ruinas ceremoniales Mayas en el curso inferior del Rio Lacantun. Estudios de Cultura Maya, Vol. V, pp. 41-52, Mexico.
- Carr, R. and J.E. Hazard
1961 Map of the ruins of Tikal, El Peten, Guatemala. Tikal Report No. 11, The Univ. Museum, Philadelphia.
- Coe, M.
1966a The Maya. Praeger, New York.
1966b Three Maya relief panels at Dumbarten Oakes. Studies in Pre-Columbian art & archaeology, No. 2, Washington, D.C.
- Coe, W.R.
1959 Piedras Negras Archaeology: Artifacts, caches, and burials. Univ. Museum, Philadelphia.
1965 Tikal: Ten years study of a Mayan ruin in the lowlands of Guatemala. Expedition, Vol. 8, No. 1, Philadelphia.
- Kelemen, P.
1943 Medieval American Art. New York.
- Kidder, A.V, J.D. Jennings, and E.M. Shook
1946 Excavations at Kaminaljuyu, Guatemala. C.I.W. Pub. 561, Washington.
- Kubler, G.
1962 Art & Architecture of ancient America. Penguin, Baltimore.
- Longyear, J.
1952 Copan ceramics: A study of southwestern Maya pottery. C.I.W. Pub. 597, Washington.
- Maler, T.
1911 Explorations in the Department of Peten, Guatemala - Tikal. Mem. Peabody Mus, Harvard, Vol. 5, No. 1, Cambridge.
- Maudslay, A.P.
1889-1902 Archaeology. Biologia Centrali-Americana. London.
- Mendez, M.
1955 Descubrimiento de las ruinas de Tikal. Ant. e Hist. de Guate., Vol.VII No. 1, pp. 3-7.
- Morley, S. A
1935 Guide book to the ruins of Quirigua. C.I.W. Sup. Pub. # 16, Washington

- Proskouriakoff, T.
1950 A study of Classic Maya sculpture. C.I.W. Pub. 593, Washington.
- Rands, R.L.
1953 The water-lily in Maya art: A complex of alleged Asiatic origin. Smithsonian Instit., Bur. of Am. Ethnology, Anthro. Papers, No. 34, Washington.
1955 Some manifestations of water in Mesoamerican art. *ibid.* No. 48.
- Ruppert, K., J.E.S. Thompson, & T. Proskouriakoff
1955 Bonampak, Chiapas, Mexico. C.I.W. Pub. 602, Washington.
- Smith, A.L.
1934 Two recent find ceramic finds at Uaxactun. C.I.W. Pub. 436, No.5 Washington.
1950 Uaxactun, Guatemala: Excavations of 1931-1937. *Ibid.*, Pub. 588.
- Smith, R.E.
1955 Ceramic sequence at Uaxactun, Guatemala. Mid. Am. Research Institute. Tulane Univ. Pub. 20. New Orleans.
- Spinden, H.
1913 A study of Maya art. *Memoirs. Pea Mus. Harvard. Vo. 9, No. 1. Cambridge*
- Thompson, J.E.S.
1960 Maya Hieroglyphic writing. Univ. of Okla. Press. Norman, Okla.

1962 A catalog of Maya hieroglyphica. Univ. of Okla. Press. Norman.
- Tozzer, A.M.
1911 A preliminary study of the prehistoric ruins of Tikal, Guatemala. *Mem. Pea. Mus., Harvard, Vol. 5 No. 2, Cambridge.*
- Webster, H.T.
1963 Tikal Graffiti. Expedition, Vol. 6, No. 1, pp. 36-47.

CREDITS

All drawings of pottery and other offerings are by Miss Virginia Greene, Tikal Project

All black and white photos of offerings are by W.R. Coe.

All color photographs and black & white of excavations are by the writer.

GLOSSARY

Construction Stage

A structure subdivision determined by observation of a pause line indicating completion of one erected operation.

Time-span

A sequent segment of time as represented by stratification or other evidence in the context of individual investigations. A given time-span is meaningful because of what can be assigned to it. In the case of construction, sequent "architectural developments" are a fundamental source for a series of time-spans. However, post-constructional human activity (that is, within the scope of the excavation), if it can be segregated, may become the principal diagnostic for formulation of the most recent time-spans. Time-spans are numbered in reverse order of time, keeping the series open at the, early end, as in the case of architectural developments which may often, as noted, delineate the time-span themselves (Coe, 1961, p. 121).

